

**CATÁLOGO**

**TARIFA**

**CATALOGUE**

**RATE**

*CATALOGUE*

*TARIF*

2

0

2

2



**SACOPISA**

EQUIPAMIENTO ALIMENTACIÓN Y HOSTELERÍA



**SACOPI SA**  
EQUIPAMIENTO ALIMENTACIÓN Y HOSTELERÍA

## QUIENES SOMOS

**Somos una empresa española de carácter familiar creada en 1972, situada a 20 km. de Barcelona, dedicada a la fabricación y distribución de equipamiento para la industria alimentaria y el sector hostelero.**

## HISTORIA

**En nuestros inicios, nos dedicamos en exclusiva al tratamiento de la madera para el sector de la alimentación y la hostelería, concretamente, a la fabricación de tajos y pilones. Esta especialización durante años nos ha convertido en el líder de estos productos en España. Más tarde, empezamos a trabajar también con polietileno, para responder a las necesidades del mercado. Introdujimos asimismo toda la gama de accesorios y maquinaria que completan la gama de productos necesarios en nuestro sector: picadoras, carteles, cuchillos, envasadoras, bandejas... y un largo etcétera hasta llegar a un total de más de 2500 referencias que se pueden encontrar en nuestro catálogo, en continua evolución para incorporar las novedades que vamos recogiendo en los diferentes mercados internacionales del sector.**

## EXPANSIÓN INTERNACIONAL

**Nuestra inquietud por innovar nos lleva a visitar y exponer en las principales ferias del sector en Europa y otras partes del mundo, para conocer los avances del sector. De hecho, actualmente exportamos a CEE, Norte de África, Emiratos y Sudamérica.**

## OBJETIVO

**Nuestro propósito es ofrecer un servicio de calidad con eficacia y rapidez y asesorar adecuadamente a nuestros clientes para adaptarnos a sus características particulares.**

## ABOUT US

We are a Spanish family company established in 1972, located 20 km. Barcelona, dedicated to the manufacture and distribution of equipment for the food industry and the hospitality industry.

## HISTORY

In our beginnings, we are dedicated exclusively to the treatment of wood for the food industry and catering specifically to the manufacture of gashes and pylons. This specialization for years has made us the leader of these products in Spain. Later, we began to also work with polyethylene to meet market needs. We introduced the full range of accessories and machinery which complete the range of products needed in our industry: grinding machines, tags, knives, packaging, trays... and so on until a total of more than 2500 references that can be found in our catalog, constantly evolving to incorporate new features that we collect in various international markets sector.

## INTERNATIONAL EXPANSION

Our concern for innovation leads us to visit and exhibit at the main trade fairs in Europe and other parts of the world, to the progress of the sector. In fact, we currently export to CEE, North Africa, Emirates and South America.

## OBJECTIVE

Our purpose is to offer a quality service efficiently and quickly and properly advise our clients to suit their particular characteristics.

## QUI SOMMES NOUS

*Nous sommes une entreprise familiale espagnole établie en 1972, situé à 20 km. Barcelone, dédiée à la fabrication et la distribution d'équipements pour l'industrie alimentaire et l'industrie hôtelière.*

## HISTOIRE

*Dans nos débuts, nous nous consacrons exclusivement au traitement du bois pour l'industrie alimentaire et de la restauration en particulier à la fabrication de estafilades et des pylônes. Cette spécialisation des années a fait de nous le leader de ces produits en Espagne.*

*Plus tard, nous avons commencé à travailler également avec du polyéthylène, pour répondre aux besoins du marché. également introduit la gamme complète d'accessoires et de machines qui complètent la gamme de produits nécessaires dans notre industrie: déchiqueuses, des affiches, des couteaux, des emballageuses, des plateaux... et ainsi de suite jusqu'à un total de plus de 2500 références qui peuvent être trouvés dans notre catalogue, en constante évolution pour intégrer de nouvelles fonctionnalités que nous recueillons dans divers secteurs des marchés internationaux.*

## EXPANSION INTERNATIONALE

*Notre souci d'innovation nous amène à visiter et d'exposer les principales foires commerciales en Europe et d'autres parties du monde, les progrès du secteur. En fait, nous exportons actuellement CEE, Afrique du Nord, Emirats et Amérique du Sud.*

## OBJECTIF

*Notre but est d'offrir un service de qualité efficacement et rapidement et correctement conseiller nos clients en fonction de leurs caractéristiques particulières.*

0 1

**Tajos, Tacos sobre mostrador, Pilones, Trípodes, Polietileno, Mesas de madera, Mesas acero-inox, Complementos, Polietileno mesa-cocina, Palas polietileno, Soportes tablas polietileno.**

Chopping block tables, cutting boards on counters, Polyethylene, Wooden tables, Stainless steel tables, Accessories, Kitchen table polyethylene, Polyethylene utility paddles, Polyethylene board stand.

*Billots de boucher, Blocs sur comptoir, Polyéthylènes, Tables en bois, Tables en acier-inox, Accessoires, Poléthylène table-cuisine, Pelles polyéthylène, Supports table polyéthylène.*

1 - 20

0 2

**Carteles portaprecios, Peana - Plataformas - Pinzas, Listas de precios, Carteles señalización, Guirnalda, Separadores, Barreños, Base rodante, Cubetas, Bandejas, Gastronorm, PlexiLine.**

Price tag holder, Stand - platforms - Clips, Price lists, Sign, Garlands, Separators, Tubs, Rolling base, Containers, Trays, Gastronorm, PlexiLine.

*Affiches porte prix, Socle - plate-formes - clips, Liste prix, Affiches signalization, Guirlandes, Séparateurs, Bassines, Base roulante, Bacs, Plateaux, Gastronorm, PlexiLine.*

21 - 62

0 3

**Picadoras, Picadora refrigerada, Cuchillas Placas, Empujadores picadoras, Cortadoras, Ralladora, Exprimidor, Cortadora multifunción, Entenercedor de carne, Cutters, Molino, Afiladoras, Cintas de sierra.**

Mincers, Refrigerated mincers, Blades plates, Mincer pusher, Slicer, Grater, Juicer, Multi-purpose slicer, Meat tenderizer, Cutters, Mill, Sharpener, Band saws.

*Hachoirs, Hachoirs réfrigérés, Lames plaques, Poussoir hachoirs, Trancheuse, Râpes, Presse, Decoupoir multifonction, Attendrissant, Cutter, Moulin, Aiguiseur, Scies à ruban.*

63 - 86

0 4

**Maquinas retractilar, Film, Dispensadores de film, Dispensador papel aluminio, Soldadoras de bolsas, Máquina sellar, Máquina vacío, Parrilla envasadora, Bolsas vacío, Termoselladora.**

Wrapping machines, Film, Film dispensers, Aluminium foil dispenser, Bag sealer, Sealer machine, Vacuum machine, Packaging grill, Vacuum bags, Thermo sealer.

*Machine à retractiler, Film, Dispensateurs film, Dispensateur papier aluminium, Scelleuse de sacs, Machine à sceller, Machine vide, Grill à sceller, Sacs sous vide, Thermo machine.*

87 - 100

0 5

**Secamanos, Dispensadores papel celulosa, Papel celulosa, Dosificadores jabón, Grifos - caño electrónico, Grifos ducha, Lavamanos, Portacuchillos - Papeleras, Esterilizadores de cuchillos, Contenedores plástico, Contenedores papeleras acero-inoxidable, Cañón de ozono.**

Hand dryer, Cellulose paper dispenser, Cellulose paper, Soap dispensers, Tap with electronic spout, Shower tap, Washbin, Knife holder - Waste baskets, Knives sterilizer, Plastic container, Stainless steel containers-bins, Ozone cannon.

*Sèche-mains, Dispensateur papier cellulose, Papier cellulose, Doseurs de savon, Robinet électronique, Robinet douche, Lave - mains, Porte couteaux - Poubelles, stérilisateur de couteaux, Conteneurs plastique, Conteneur-poubelle acier inox, Canon à ozone.*

101 - 120

0 6

**Indicadores de turno, Expendedores de tickets, Impresora de tickets, Rollo tickets, Organizador de filas, Exterminadores de insectos, Detector contador billetes - monedas, Reloj-temperatura.**

Queue indicators, Ticket dispenser, Tickets printer, Ticket roll, Row organizer, Insect exterminator, Counter detector bill - coin, Clock - temperature.

*Indicateur de numero, Dispensateur tickets, Imprimante tickets, Rouleaux de tickets, Organisateur de rangée, Exterminateur d'insectes, Compteur détecteur billets - monnaie, Horloge - température.*

121 - 134

0 7

**Hamburgueseras, Papel celofán, Embutidoras, Jamoneras, Jamonero rotatorio 360°, Ganchos, Libradores, Pinzas, Molde brochetas, Entenercedor carne, Malla y anillas elásticas, Protector hueso, Termómetros.**

Hamburger presses, Cellophane foil, Sausage filler, Jamoneras, Rotary Ham holder 360°, Hooks, Scoops, Tongs, Brochette mold, Meat tenderizer, Elastic mesh and rings, Bone protector, Thermometer.

*Hachoirs, Papiers cellophane, Emboutisseuses, Jamoneras, Support de jambon rotatif 360°, Crochets, Pelles à main, Pincas, Moule brochettes, Attendrisseur, Maille et anneaux élastiques, Protecteur d'os, Thermomètre.*

135 - 148

0 8

**Cierra bolsas - rollos, Etiquetadoras-rollos, Navateadoras, Espejos vigilancia, Carro servicio - Bandejero, Cestos - carros autoservicio, Dispensadores bolsas, Carros Gastronorm.**

Bag-roll sealer, Labellers-rolls, Labelling gun, Vigilance mirror, Service trolley - tray, Self-service basket - trolley, Bags dispensers, Gastronorm trolley.

*Machines ferme sacs, Étiquetteuses-rolls, Pistolet à étiqueter, Miroir de surveillance, Chariot service - Plateau, Panier - chariot self-service, Dispensateurs sacs, Chariot Gastronorm.*

149 - 160

0 9

**Cuchillería profesional, Afiladores, Chairas, Hachas, Tijeras, Espátulas, Bacaladera, Abre-Ostras, Sierras, Imanes, Guillotinas queso, Sacacorchos, Abrelatas, Guantes, Delantes, Material de un uso, Delantales protección, Guantes frío, Guantes malla acero-inox, Guantes y manoplas calor.**

Professional knives, Sharpeners, Axes, Scissors, Spatulas, Fish shears, Oyster sucker, Saws, Magnets, Cheese guillotines, Corkscrew, Can openers, Gloves, Aprons, Disposable material, Protective aprons, Cold gloves, Mesh steel-stainless gloves, Gloves and mittens heat.

*Couteaux professionnels, Aiguiseurs, Scies, Ciseaux, Spatules, Moorutiel manuel, Couteau à huîtres, Scies, Aimants, Guillotines à fromage, Tire-Bouchon, Ouvre-Boîtes, Gants, Tabliers, Material d'un seul usage, Tabliers de protection, Gants froid, Gants en acier inoxydable, Gants et mitaines chaleur.*

161 - 182

1 0

**Estanterías, Plataformas, Tarima antifatiga, Palets, Losetas, Bancos de vestuario, Taquillas.**

Shelves, Platforms, Anti-fatigue may, Pallets, Tiles, Locker room bench, Lockers.

*Étagères, Plate-formes, Sol anti-fatigue, Palettes, Carreaux, Banc vestiaire, Casiers.*

183 - 196

**Recambios / Spare Parts / Pieces de Rechange**

**Carteles portaprecios, Guantes acero-inox, Indicadores de turno, Grifos ducha, Soldadores de bolsa, Esterilizadores, Máquinas retractilar, Máquinas cierra bolsas, Hamburgueseras, Máquinas cierra bolsas, Etiquetadoras, Abrelatas, Exterminadores-tubos.**

Tag holders, Stainless steel gloves, Queue indicators, Shower taps, Bag sealers, Sterilisers, Wrapping machines, Burger presses, Labellers, Can opener, Insect exterminators-tubes.

*Affiches porte-prix, Gants d'inox, Indicateurs de tour, Robinets douche, Scelleuse de sacs, Stérilisateurs, Machines à retractiler, Machine ferme sacs, Hachoirs, Étiquetteuses, Ouvre-boîtes, Exterminateurs d'insectes-tubes.*

197 - 202



SUBDIRECCIÓN GENERAL  
DE GESTIÓN DE RIESGOS  
ALIMENTARIOS  
REGISTRO GENERAL  
SANITARIO DE ALIMENTOS

1/1

1.	Nombre o Razon Social <b>SACOPISA S.L.</b>		
2.	Domicilio Social C/ VALLES 5 (POL. IND. CAN CASABLANCAS) SANT QUIRZE DEL VALLES		BARCELONA
3.	Actividad de la Industria <b>FABRICACION Y/O ELABORACION Y/O TRANSFORMACION DE MATERIAS PLASTICAS FABRICACION Y/O ELABORACION Y/O TRANSFORMACION DE MADERA, CORCHO, CUERO, PIELS Y FIBRAS NATURALES</b>		
4.	Domicilio Industrial C/ VALLES 5 (POL. IND. CAN CASABLANCAS) SANT QUIRZE DEL VALLES		BARCELONA
5.	Clave 39	Categ. / Act./s 0101, 0109	Núm. Registro Sanitario <b>39.04434/B</b>

De conformidad con lo dispuesto en el artículo segundo del Real Decreto 1712/1991, de 29 de noviembre (B.O.E. de 4 de diciembre), y a tenor de la autorización concedida, ha quedado inscrita la industria de referencia en el Registro General Sanitario de Alimentos con el número arriba indicado.

Madrid, 22 de Octubre de 2010

EL TÉCNICO SUPERIOR

Miguel Ángel Casas Paulet

AREA DE AUTORIZACIONES Y REGISTROS (DIVISION DE GESTION DE RIESGOS)  
AGENCIA DE PROTECCION DE LA SALUD  
BARCELONA

Generalitat de Catalunya  
Agència de Salut Pública de Catalunya

SACOPI SA SL  
Polígon Industrial Can Casablanques sortida  
CR Vallès, 5  
08192 SANT QUIRZE DEL VALLÈS

D'acord amb la sol·licitud presentada i havent tramitat l'expedient corresponent, ha quedat **ACTUALITZADA** la situació de l'empresa de referència en el Registre sanitari d'indústries i productes alimentaris de Catalunya (RSIPAC), amb les dades següents:

*De conformidad con la solicitud presentada y tramitado el expediente correspondiente, ha quedado **ACTUALIZADA** la situación de la empresa de referencia en el Registro Sanitario de Industrias y Productos Alimentarios de Cataluña (RSIPAC), con los datos siguientes:*

**IDENTIFICACIÓ DE L'EMPRESA/IDENTIFICACIÓN DE LA EMPRESA**

Raó social/razón social NIF/NIE/CIF  
SACOPI SA SL B60206810

Adreça social/domicilio social  
Polígon Industrial Can Casablanques  
CR Vallès, 5 X: 423992  
08192 SANT QUIRZE DEL VALLÈS Y: 4600634

Adreça industrial/domicilio industrial  
Polígon Industrial Can Casablanques  
CR Vallès, 5 X: 423992  
08192 SANT QUIRZE DEL VALLÈS Y: 4600634

Núm. RSIPAC: 39.05165/CAT Núm. RGSEAA: 39.04434/B

Data Inscripció/fecha inscripción: 07/09/2010

**ACTIVITATS / ACTIVIDADES**

Ciau: 39

Codi	Descripció
01/01	Fabricació o elaboració o transformació de matèries plàstiques
01/09	Fabricació o elaboració o transformació de fusta, suro, cuir, pells i fibres naturals

Clave: 39

Código	Descripción
01/01	Fabricación o elaboración o transformación de materias plásticas
01/09	Fabricación o elaboración o transformación de madera, corcho, cuero, pieles y fibras naturales

Roc Boronat, 81-95  
Barcelona . 93 551 39 00 / Fax 93 551 75 05  
<http://www.gencat.cat/salut>

SALUT

Document electrònic garantit amb signatura electrònica. Podeu verificar la integritat d'aquest document a l'adreça web [csv.gencat.cat](http://csv.gencat.cat)

Original electrònic / Còpia autèntica

CODI SEGUR DE VERIFICACIÓ



01DBVIPDK3N0IMSEB1W8U23LY2J4NUHL

Doc.original signat per:  
CPISR-1 Maria Alba Pascual  
Cardona  
12/07/2016

Data creació còpia:  
13/07/2016  
Data caducitat còpia:  
13/07/2019  
Pàgina 1 de 2





**SACOPI SA**  
EQUIPAMIENTO ALIMENTACIÓN Y HOSTELERÍA

## **Declaración de conformidad**

Mediante la emisión del siguiente certificado, SACOPI SA S.L., situada en el Polígono Industrial Can Casablanças calle Vallés nº5, declara que los productos mencionados a continuación:

- **Pilones;**
- **Tacos**
- **Tablas de corte;**
- **Tajos;**

Cumplen con los requisitos exigidos por el **Reglamento 1935/2004**, sobre materiales y objetos destinados a entrar en contacto con alimentos. Ante la falta de normativa regulatoria específica sobre madera declaramos que nuestros productos cumplen con los requisitos alemanes específicos para madera en contacto con alimentos regulados por la **LFGB** de manera que:

- Los niveles de migración de formaldehído;
- Los niveles de migración de DEPH, DBP i DiBP;
- Los niveles de migración de fenoles clorados PCP, TeCP, TriCP (GC-ECD);
- Los niveles de pesticidas básicos;

no suponen un riesgo para la salud humana ni alteran las características organolépticas del producto.

Con esto, declaramos que nuestros productos son **aptos para el contacto con alimentos** según la normativa actual y así lo ratifica mediante la siguiente firma:

Jordi Gálvez Alsina,

En calidad de gerente

Sant Quirze del Vallés, 23 de febrero del 2017



**Reservamos el derecho a modificar ó alterar nuestros productos sin previo aviso.  
Los precios son válidos salvo error tipográfico o de impresión.**

We reserve ourselves the right to modify our products without notice it previously.  
Prices are valid except for typographical errors or printing.

*Nous réservons le droit de modifier nos produits sans préavis.  
Les prix sont valables sauf erreur typographique ou d'impression.*

0

1

**Tajos, Tacos sobre mostrador, Pilonos, Trípodes, Polietilenos, Mesas de madera, Mesas acero-inox, Complementos, Polietileno mesa-cocina, Palas polietileno, Soportes tablas polietileno.**

---

Chopping block tables, cutting boards on counters, Polyethylene, Wooden tables, Stainless steel tables, Accesories, Kitchen table polyethylene, Polyethylene utility paddles, Polyethylene board stand.

---

*Billots de boucher, Blocs sur comptoir, Polyéthylènes, Tables en bois, Tables en acier-inox, Accessoires, Poléthylène table-cuisine, Pelles polyéthylène, Supports table polyéthylène.*

**1 - 19**

Todos nuestros productos fabricados están elaborados con maderas de encina, acacia, plátano y haya previamente seleccionada y tratada con riguroso proceso de secado para sustraer la humedad, savia y glutinosa de la madera, dejando todas las betas limpias para que dicho producto no tenga impurezas en su interior.

Consiguiendo con este proceso que al manipular los alimentos no desprendan ningún tipo de impurezas. Para la conservación de la madera de nuestros productos fabricados, recomendamos usar nuestro rascador Ref. A-80 diariamente, para así conseguir mantener la superficie totalmente lisa y limpia.

No utilizando productos químicos que dañarian la conservación de nuestros pilones, tajos, tacos y mesas de madera. Todos los productos están autorizados por sanidad.

All our products are made with holm oak wood, previously selected and treated with a rigorous drying process to remove moisture, sap and glutinous wood, leaving all streaks clean in order to get a product with no impurities.

With this process, the food can be manipulated without any kind of impurities.

In order to get a better wood preservation of our products, we recommend using our scraper, Ref A-80, daily to keep it completely smooth and clean.

Do not use chemical products that could damage the conservation of our chopping blocks and wooden tables.

All products used are legally approved.

Tous nos produits sont fabriqués en bois de chêne vert, préalablement sélectionnés et traité avec un processus rigoureux séchage pour enlever l'humidité, le sève et le gluant du bois, en laissant tout le bois propre pour ce produit ne contienne pas d'impuretés en elle. Grâce à ce processus, lorsque vous manipulez des aliments aucune substance ne sera en dommagée.

Pour protéger le bois de nos produits, nous vous recommandons d'utiliser notre décapeuse Réf A-80 tous les jours, pour garder la surface lisse et propre. Utiliser de produits chimiques pourrait nuire à la conservation des pieds, des billots et des tables en bois.

Tous nos produits sont approuvés par le Ministère de la santé.



Ref.	Medidas Size Dimensions	Euros
EC-10	38 x 9 x 38 cm	120,00

**Portacuchillos protegido, acero-inox**  
**Con tres ranuras para cuchillos y chaira ovalada-redonda**

Encased knife holder, stainless steel  
Three grooves for knives and oval professional sharpener

Porte couteaux et fusil ovale rond, acier inox  
Avec trois rainures pour couteaux et fusil ovale rond



**Rascador**  
**Para limpieza de pilones y tajos**  
**de madera M**

Grater  
Inyectado chopping blocks

Grattoir  
Pour billots

Ref.	Euros
A-80	21,50



**Cepillo limpieza tablas**  
**polietileno**

Polyethylene cutting board  
brush

Brosse nettoyage planches  
poléthylène

Ref.	Euros
A-81	52,50

**Recambio cuchilla A-81**

Spare blade A-81

Lame de rechange A-81

Ref.	Euros
A-81-1	19,00



**Portacuchillo de madrea**

Wooden knife holder

Porte-couteaux en bois

Ref.	Euros
V-PORMAD	15,00

**Portacuchillo de polietileno**

Polyethylene knife holder

Porte-couteaux en polyéthène

Ref.	Color Colour Couleur	Euros
V-PORPOLB	○	30,00
V-PORPOLR	●	30,00

**Portacuchillo de varilla acero-inox para tajo**

Stainless steel Knife holder for block

Porte-coutaux en inox pour billot

Ref.	Tipo Type Type	Euros
V-PORACE-40	40	49,00
V-PORACE-44	44	53,00
V-PORACE-50	50	57,00





**Tope valdilla acero inox**

Stainless steel buffer

*Bout acier inox*

Ref.	Euros
V-VALDILLA	4,50



**Guía tope vitrina inox**

Stainless steel guides

*Guides acier inox*

Ref.	Medidas Size Dimensions	Euros
V-GUIA-40	40 x 3 x 2 cm	7,50

**Pie regulable para pata inox**

Adjustable foot for stainless steel legs

*Pieds réglables pour inox pattes*

Ref.	Euros
V-PR	3,00

**Goma antideslizante**

Stopper antiskid

*Gomme antidérapante*

Ref.	Euros
V-GOMA	0,45

**Pie fijo para patas inox**

Fixed foot for stainless legs

*Pieds fixes pour inox pattes*

Ref.	Euros
V-PF	1,50

**TAJOS DE 4 PATAS CON TACO MADERA | CHOPPING BLOCKS WITH 4 LEGS | BILLOTS AVEC 4 PIEDS**



**A - Tajo de 4 patas madera  
Sin portacuchillos. Altura total 90 cms.**

A - 4-leg wooden chopping block table  
Without knife holder. Total height 90 cm.

*A - Billot de boucher 4 pattes bois  
Sans porte couteaux. Hauteur totale 90 cm.*

Ref.	Medida taco Cutting board size Mesure bloc	Euros	Ref.	Medida taco Cutting board size Mesure bloc	Euros	Ref.	Medida taco Cutting board size Mesure bloc	Euros
V-A604025E	60 x 40 x 25 cm	695,00	V-A404025E	40 x 40 x 25 cm	482,00	V-A404015E	40 x 40 x 15 cm	381,00
V-A644425E	64 x 44 x 25 cm	828,00	V-A444425E	44 x 44 x 25 cm	593,00	V-A443215E	44 x 32 x 15 cm	365,00
V-A705025E	70 x 50 x 25 cm	924,00	V-A505025E	50 x 50 x 25 cm	687,00	V-A604015E	60 x 40 x 15 cm	476,00
V-A804025E	80 x 40 x 25 cm	876,00				V-A806015E	80 x 60 x 15 cm	807,00
V-A884425E	88 x 44 x 25 cm	1030,00						
V-A1005025E	100 x 50 x 25 cm	1250,00						



**I - Tajo de 4 Pata de acero inox con faldón Sin portacuchillos. Altura total 90cms.**

I - Chopping block with 4 stainless steel legs with drawer  
Whithout knifeholder. Total height 90 cm.

*I - Billots avec 4 pieds en inox avec jupe  
Sans porte couteaux. Hauteur totale 90 cm.*

Ref.	Medida taco Cutting board size Mesure bloc	Euros
V-1404025E	40 x 40 x 25 cm	645,00
V-1444425E	44 x 44 x 25 cm	760,00
V-1505025E	50 x 50 x 25 cm	870,00
V-1604025E	60 x 40 x 25 cm	857,00

Ref.	Medida taco Cutting board size Mesure bloc	Euros
V-1644425E	64 x 44 x 25 cm	1011,00
V-1705025E	70 x 50 x 25 cm	1126,00
V-1804025E	80 x 40 x 25 cm	1114,00
V-1884425E	88 x 44 x 25 cm	1315,00
V-11005025E	100 x 50 x 25 cm	1594,00



**I-2 - Tajo de 4 patas de acero-inox sin faldón Sin portacuchillos. Altura total 90 cms.**

I-2 - Chopping block with 4 stainless legs  
without drawer  
Without knife holder. Total height 90 cm.

*I-2 - Billots avec 4 pieds en inox sans jupe  
Sans porte couteaux. Hauteur totale 90 cm.*

Ref.	Medida taco Cutting board size Mesure bloc	Euros
V-12404025E	40 x 40 x 25 cm	625,00
V-12444425E	44 x 44 x 25 cm	738,00
V-12505025E	50 x 50 x 25 cm	848,00
V-12604025E	60 x 40 x 25 cm	835,00

Ref.	Medida taco Cutting board size Mesure bloc	Euros
V-12644425E	64 x 44 x 25 cm	982,00
V-12705025E	70 x 50 x 25 cm	1089,00
V-12804025E	80 x 40 x 25 cm	1030,00
V-12884425E	88 x 44 x 25 cm	1192,00
V-121005025E	100 x 50 x 25 cm	1458,00



**S - Tajo de 4 patas insonorizado de acero-inox Sin portacuchillo. Altura total 90 cms.**

S - 4-legs stainless steel sound proof anti-vibration chopping block table Without knife holder. Total height 90 cm.

S - Billot avec 4 pieds acier inox insonorisé antivibratoire. Sans porte couteaux. Hauteur totale 90 cm.

Ref.	Medida taco Cutting board size Mesure bloc	Euros
V-S443225E	44 x 32 x 25 cm	1455,00
V-S444425E	44 x 44 x 25 cm	1510,00
V-S604025E	60 x 40 x 25 cm	1680,00
V-S705025E	70 x 50 x 25 cm	1932,00

**TACOS DE MADERA | CHOPPING BLOCKS | BILLOTS**



**O - Tacos de madera cuadrados**

O - Square cutting boards

O - Blocs carrés

Ref.	Medidas Size Dimensions	Euros
V-O404015E	40 x 40 x 15 cm	215,00
V-O404025E	40 x 40 x 25 cm	337,00
V-O444410E	44 x 44 x 10 cm	194,00
V-O444420E	44 x 44 x 20 cm	395,00
V-O444425E	44 x 44 x 25 cm	444,00
V-O505025E	50 x 50 x 25 cm	545,00



**O - Tacos de madera redondos**

O - Round cutting boards

O - Blocs ronds

Ref.	Diámetro Diameter Diamètre	Altura Height Hauteur	Euros
V-O3510E	Ø 35 cm	10 cm	232,00
V-O3515E	Ø 35 cm	15 cm	290,00
V-O3520E	Ø 35 cm	20 cm	376,00



**G - Tacos de madera rectangulares**

G - Rectangular cutting boards

G - Blocs rectangulaires

Ref.	Medidas Size Dimensions	Euros
V-G443210E	44 x 32 x 10 cm	154,00
V-G443215E	44 x 32 x 15 cm	190,00
V-G443220E	44 x 32 x 20 cm	381,00
V-G443225E	44 x 32 x 25 cm	430,00

Ref.	Medidas Size Dimensions	Euros
V-G604025E	60 x 40 x 25 cm	532,00
V-G644425E	64 x 44 x 25 cm	661,00
V-G705025E	70 x 50 x 25 cm	756,00
V-G804025E	80 x 40 x 25 cm	711,00
V-G884425E	88 x 44 x 25 cm	854,00
V-G1005025E	100 x 50 x 25 cm	1065,00
V-G604015E	60 x 40 x 15 cm	292,00
V-G806015E	80 x 60 x 15 cm	583,00

**Tabla de corte en madera**

Wooden cutting board

Planche à découper en bois



Ref.	Medidas Size Dimensions	Euros
V-T50355	50 x 35 x 4,2 cm	104,00
V-T50405	50 x 40 x 4,2 cm	120,00



**B - Pilón graduable descentrado expox**  
**Altura pie mínima 65 máxima 110 cm. Modelo ideal para espacios reducidos, trabajando la parte superior por encima del mostrador, evitando perjudicar con el golpe la vitrina. Al mismo tiempo aprovechamos la anchura del pasillo. Graduación a la altura de corte desea. Colocación: 4 tornillos al suelo. Se puede montar con tacos cuadrados ó polietileno.**

**B - Adjustable decentred epoxy leg**  
 Minimum leg height 65, maximum 110 cm. An ideal model for cramped spaces, enables you to work on top of the counter thus avoiding any damage to glass display. It also gives you more room behind the counter. Adjustable to the desired chopping height. Placing: 4 screws on the floor. Can be assembled with square blocks or polyethylene.

**B - Pied réglable décentré époxy**  
 Hauteur pied minimum 65, maximum 110 cm. Modèle idéal pour les espaces réduits, pour travailler sur la partie supérieure du comptoir en évitant de porter un coup à la vitrine. Nous profitons du même coup de la largeur du couloir. Réglable à l'hauteur de coupe désirée. Lieu: 4 vis sur le sol. Il peut être monté avec billots carrés.

Ref.	Euros
V-BPGD	336,00



**B - Pilón graduable descentrado acero-inox**  
**Altura pie mínima 80, máxima 105 cm. Modelo ideal para espacios reducidos, trabajando la parte superior por encima del mostrador, evitando perjudicar con el golpe la vitrina. Al mismo tiempo aprovechamos la anchura del pasillo. Graduación a la altura de corte deseada. Colocación: 4 tornillos al suelo. Se puede montar con tacos cuadrados o redondos.**

**B - Adjustable decentred stainless steel leg**  
 Minimum leg height 80, maximum 105 cm. An ideal model for cramped spaces, enables you to work on top of the counter thus avoiding any damage to glass display. It also gives you more room behind the counter. Adjustable to the desired chopping height. Placing: 4 screws on the floor. Can be assembled with square or round blocks.

**B - Pied réglable décentré acier inox**  
 Hauteur pied minimum 80, maximum 105 cm. Modèle idéal pour les espaces réduits, pour travailler sur partie supérieure du comptoir en évitant de porter un coup à la vitrine. Nous profitons du même coup de la largeur du couloir. Réglable à l'hauteur de coupe désirée. Lieu: 4 vis sur le sol. Il peut être monté avec billis carrés ou ronds.

Ref.	Euros
V-BPGDI	768,00

**H - Tablas de polietileno  
Grosor 1,5 cm**

H - Polyethylene boards  
Thickness 1.5 cm

H - Plaques en polyéthylène  
Épaisseur 1,5 cm

Ref.	Medidas Size Dimensions	Euros
V-H25191.5	25 x 19	9,50
V-H30201.5	30 x 20	11,20
V-H33191.5	33 x 19	12,30
V-H33331.5	33 x 33	20,40
V-H40201.5	40 x 20	14,90
V-H40251.5	40 x 25	18,60
V-H40301.5	40 x 30	22,20
V-H40331.5	40 x 33	24,50
V-H40401.5	40 x 40	29,80
V-H50251.5	50 x 25	23,20
V-H50301.5	50 x 30	27,90
V-H50331.5	50 x 33	30,70
V-H50401.5	50 x 40	37,20
V-H50501.5	50 x 50	46,40
V-H60251.5	60 x 25	27,90
V-H60301.5	60 x 30	33,40
V-H60331.5	60 x 33	36,80
V-H60401.5	60 x 40	44,50
V-H75251.5	75 x 25	34,80
V-H75331.5	75 x 33	46,00
V-H100251.5	100 x 25	46,35
V-H100331.5	100 x 33	61,25
V-H150251.5	150 x 25	69,50
V-H150331.5	150 x 33	92,00
V-H200251.5	200 x 25	93,00
V-H200331.5	200 x 33	123,00
V-H2001001.5	200 x 100	366,00

**H - Tablas de polietileno  
Grosor 2 cm**

H - Polyethylene boards  
Thickness 2 cm

H - Plaques en polyéthylène  
Épaisseur 2 cm

Ref.	Medidas Size Dimensions	Euros
V-H25192	30 x 20	12,20
V-H30202	30 x 20	14,30
V-H33192	33 x 19	15,80
V-H33332	33 x 33	26,00
V-H40202	40 x 20	19,10
V-H40252	40 x 25	23,90
V-H40302	40 x 30	28,60
V-H40332	40 x 33	31,60
V-H40402	40 x 40	38,20
V-H50252	50 x 25	29,80
V-H50302	50 x 30	36,80
V-H50332	50 x 33	39,50
V-H50402	50 x 40	47,70
V-H50502	50 x 50	59,50
V-H60252	60 x 25	35,80
V-H60302	60 x 30	43,00
V-H60332	60 x 33	47,40
V-H60402	60 x 40	57,10
V-H75252	75 x 25	44,60
V-H75332	75 x 33	59,20
V-H100252	100 x 25	59,50
V-H100332	100 x 33	79,00
V-H150252	150 x 25	89,20
V-H150332	150 x 33	118,50
V-H200252	200 x 25	119,00
V-H200332	200x 33	157,50
V-H2001002	200 x 100	469,00

**H - Tablas de polietileno  
Grosor 3 cm**

H - Polyethylene boards  
Thickness 3 cm

H - Plaques en polyéthylène  
Épaisseur 3 cm

Ref.	Medidas Size Dimensions	Euros
V-H25193	25 x 19	18,20
V-H30203	30 x 20	21,50
V-H33193	33 x 19	23,60
V-H33333	33 x 33	39,00
V-H40203	40 x 20	28,60
V-H40253	40 x 25	35,80
V-H40303	40 x 30	42,90
V-H40333	40 x 33	47,20
V-H40403	40 x 40	57,10
V-H50253	50 x 25	44,60
V-H50303	50 x 30	53,60
V-H50333	50 x 33	60,00
V-H50403	50 x 40	71,40
V-H50503	50 x 50	89,10
V-H60253	60 x 25	53,60
V-H60303	60 x 30	64,40
V-H60333	60 x 33	70,80
V-H60403	60 x 40	85,60
V-H75253	75 x 25	67,00
V-H75333	75 x 33	88,50
V-H100253	100 x 25	89,20
V-H100333	100 x 33	118,00
V-H150253	150 x 25	133,80
V-H150333	150 x 33	177,00
V-H200253	200 x 25	179,00
V-H200333	200 x 33	236,00
V-H2001003	200 x 100	703,00



MN= Marmóreo N/B / Marmorean / Marmoréen  
M= Marmóreo R/B / Marmorean / Marmoréen  
B= Blanco / White / Blanc

A= Amarillo / Yellow / Jaune  
S= Salmón / Salmon / Saumon  
R= Rojo / Red / Rouge

V= Verde / Green / Vert  
AZ= Azul / Blue / Bleu  
N= Negro / Black / Noir

RV= Rojo Vivo / Light Red / Rouge Vivant

**H - Tablas de polietileno Grosor 4 cm**

H - Polyethylene boards  
Thickness 4 cm

H - Plaques en polyéthylène  
Épaisseur 4 cm

Ref.	Medidas Size Dimensions	Euros
V-H25194	25 x 19	24,20
V-H30204	30 x 20	28,60
V-H33194	33 x 19	31,50
V-H33334	33 x 33	51,90
V-H40204	40 x 20	38,10
V-H40254	40 x 25	47,70
V-H40304	40 x 30	57,10
V-H40334	40 x 33	62,90
V-H40404	40 x 40	76,20
V-H50254	50 x 25	59,60
V-H50304	50 x 30	71,40
V-H50334	50 x 33	78,60
V-H50404	50 x 40	95,20
V-h50504	50 x 50	118,90
V-H60254	60 x 25	71,40
V-H60304	60 x 30	85,70
V-H60334	60 x 33	94,30
V-H60404	60 x 40	114,10
V-H75254	75 x 25	89,20
V-H75334	75 x 33	117,90
V-H100254	100 x 25	119,00
V-H100334	100 x 33	157,00
V-H150254	150 x 25	178,50
V-H150334	150 x 33	236,00
V-H200254	200 x 25	238,00
V-H200334	200 x 33	314,50
V-H2001004	200 x 100	936,00

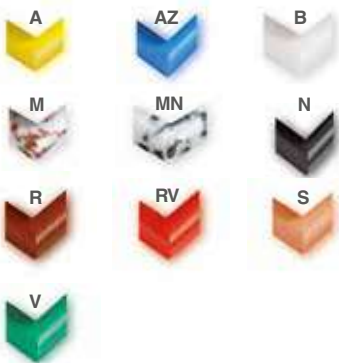

**Tablas de polietileno Grosor 5 cm**

Polyethylene boards  
Thickness 5 cm

Plaques en polyéthylène  
Épaisseur 5 cm

Ref.	Medidas Size Dimensions	Euros
V-H25195	25 x 19	30,00
V-H30205	30 x 20	35,70
V-H33195	33 x 19	39,30
V-H33335	33 x 33	65,00
V-H40205	40 x 20	47,70
V-H40255	40 x 25	59,60
V-H40305	40 x 30	71,50
V-H40335	40 x 33	78,60
V-H40405	40 x 40	95,20
V-H45455	45 x 45	121,70
V-H50255	50 x 25	74,40
V-H50305	50 x 30	89,40
V-H50335	50 x 33	98,30
V-H50405	50 x 40	119,00
V-H50505	50 x 50	148,60
V-H60255	60 x 25	89,20
V-H60305	60 x 30	107,20
V-H60335	60 x 33	117,90
V-H60405	60 x 40	142,70
V-H65455	65 x 45	183,00
V-H70505	70 x 50	214,50
V-H75255	75 x 25	111,50
V-H75335	75 x 33	147,50
V-H80405	80 x 40	190,50
V-H90455	90 x 45	256,00
V-H100255	100 x 25	149,00
V-H100335	100 x 33	197,00
V-H100505	100 x 50	297,00
V-H150255	150 x 25	223,00
V-H150335	150 x 33	295,00
V-H200255	200 x 25	298,00
V-H200335	200 x 33	393,00
V-H2001005	200 x 100	1168,00

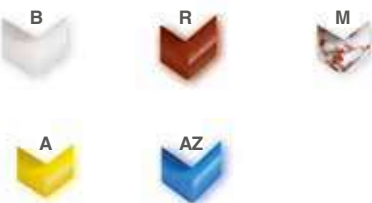

**LAS TABLAS REDONDAS Y LAS TABLAS PARA ACOPLAR SE INCREMENTARÁN 17,00 euros. / ROUNDS BOARDS AND BOARDS FOR FITTING INCREASE PRICE IN 17,00 euros. / PLAQUES RONDES ET PLAQUES POUR AJUSTER AUGMENTENT PRIX EN 17,00 euros.**

	PRECIO CORTE CM <sup>2</sup> EUROS / CUTTING PRICE / PRIX DECOUPE	COLORES / COLOURS / COULEURS
0,3 CM <sup>2</sup>	0,0072	B
1 CM <sup>2</sup>	0,0156	B
1,5 CM <sup>2</sup>	0,0214	B-R-M
2 CM <sup>2</sup>	0,0280	B-R-M-A-AZ-S-V-N-RV-MN
3 CM <sup>2</sup>	0,0410	B-R-M
4 CM <sup>2</sup>	0,0555	B-R-M-A-AZ-S-V-N-RV-MN
5 CM <sup>2</sup>	0,0688	B-R-M-A-AZ
9 CM <sup>2</sup>	0,1400	B-R
14 CM <sup>2</sup>	0,2500	B-R

**LARGO x ANCHO x EUROS CM<sup>2</sup>. EJEMPLO: TABLA MEDIDA 55x28x3. PRECIO: 55 x 28 x 0,0410 = 63,14 euros. LENGHT x WIDTH x EUROS CM<sup>2</sup>. EIXAMPLE: BOARD SIZE 55x28x3. PRICE: 55 x 28 x 0,0410 = 63,14 euros. LONG x LARGE x EUROS CM<sup>2</sup>. EXEMPLE: PLAQUE DIMENSION 55x28x3. PRIX: 55 x 28 x 0,0410 = 63,14 euros.**

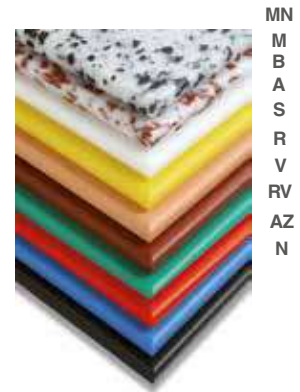

MN  
M  
B  
A  
S  
R  
V  
RV  
AZ  
N



**0 1 TABLA POLIETILENO HDPE500 HOSTELERÍA CON GOMAS ANTIDESLIZANTES | HDPE500 HOSPITALITY POLYETHYLENE BOARD WITH NON-SLIP RUBBER | PLATEAU EN POLYÉTHYLÈNE HDPE500 HOSPITALITY AVEC CAOUTCHOUC ANTIDÉRAPANT**

Ref.	Medidas Size Dimensions	Euros
Y-30201	30 x 20 x 1 cm	5,55
Y-40302	40 x 30 x 2 cm	20,75
Y-50302	50 x 30 x 2 cm	25,90
Y-60402	60 x 40 x 2 cm	41,40



**B= Blanco / White / Blanc**  
**A= Amarillo / Yellow / Jaune**  
**AZ= Azul / Blue / Bleu**  
**R= Rojo / Red / Rouge**  
**V= Verde / Green / Vert**

**TABLAS DE POLIETILENO | POLYETHYLENE BOARDS | PLAQUES EN POLYÉTHYLÈNE**

**Tablas de polietileno En Blanco (Ref + B) y Rojo (Ref + R)**

Polyethylene boards  
 In White (Ref. + B) and Red (Ref. + R)

*Plaques en polyéthylène Couleurs Blanc (Réf. + B) et Rouge (Réf. + R)*

Ref.	Medidas Size Dimensions	Euros
V-H40339	40 x 33 x 9 cm	160,00
V-H40409	40 x 40 x 9 cm	197,50
V-H45459	45 x 45 x 9 cm	261,50
V-H50339	50 x 33 x 9 cm	201,50
V-H50509	50 x 50 x 9 cm	302,50
V-H60409	60 x 40 x 9 cm	292,00
V-H403314	40 x 33 x 14 cm	287,00
V-H503314	50 x 33 x 14 cm	356,50

**F - Taco madera fabricado en cuadradillo y 5 cm polietileno rectangulares En Blanco (Ref + B) y Rojo (Ref + R)**

F - Wooden block and 5 cm rectangular polyethylene board  
 In White (Ref. + B) and Red (Ref. + R)

*F - Bloc en bois et plaque en polyéthylène rectangulaire Couleurs Blanc (Réf. + B) et Rouge (Réf. + R)*

Ref.	Medida taco Cutting board size Mesure bloc	Euros
V-F604020PL	60 x 40 x 20 cm	350,00
V-F604025PL	60 x 40 x 25 cm	392,00
V-F644520PL	64 x 45 x 20 cm	435,00
V-F644525PL	64 x 45 x 25 cm	471,00
V-F705020PL	70 x 50 x 20 cm	515,00
V-F705025PL	70 x 50 x 25 cm	574,00

**Tablas redondo de polietileno En Blanco (Ref + B) y Rojo (Ref + R)**

Round polyethylene boards  
 In White (Ref. + B) and Red (Ref. + R)

*Plaques ronds en polyéthylène Couleurs Blanc (Réf. + B) et Rouge (Réf. + R)*

Ref.	Diámetro Diameter Diamètre	Altura Height Hauteur	Euros
V-H355	Ø 35 cm	5 cm	105,50
V-H359	Ø 35 cm	9 cm	200,00
V-H3514	Ø 35 cm	14 cm	317,00
V-H405	Ø 40 cm	5 cm	132,00
V-H409	Ø 40 cm	9 cm	229,50
V-H4014	Ø 40 cm	14 cm	340,00

**F - Taco madera fabricado en cuadradillo y 5 cm polietileno cuadrados En Blanco (Ref + B) y Rojo (Ref + R)**

F - Wooden block and 5 cm square polyethylene board  
 In White (Ref. + B) and Red (Ref. + R)

*F - Bloc en bois et plaque en polyéthylène carrée Couleurs Blanc (Réf. + B) et Rouge (Réf. + R)*

Ref.	Medida taco Cutting board size Mesure bloc	Euros
V-F404020PL	40 x 40 x 20 cm	235,00
V-F404025PL	40 x 40 x 25 cm	261,00
V-F454520PL	45 x 45 x 20 cm	295,00
V-F454525PL	45 x 45 x 25 cm	321,00
V-F505020PL	50 x 50 x 20 cm	366,00
V-F505025PL	50 x 50 x 25 cm	407,00

**Agujero Ø 12 cm para tabla**

Ø 12 cm hole for table

*Trou Ø 12 cm pour table*

Ref.	Altura Height Hauteur	Euros
V-HAGU5	5 cm	40,00
V-HAGU9	9 cm	55,00
V-HAGU14	14 cm	75,00

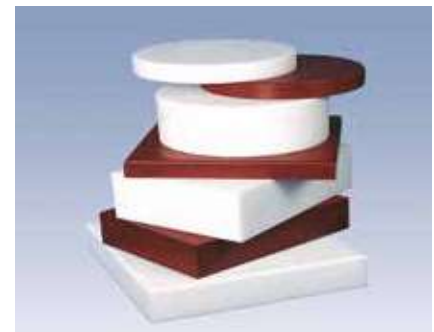





**F - Tajo de 4 patas de madera (Ref. A) con taco de madera fabricado en cuadradillo + 5 cm polietileno**  
**Sin portacuchillos. Altura total 85 cm. En Blanco (Ref + B) y Rojo (Ref + R)**

F - 4 wooden legs chopping block table (Ref. A) + 5 cm polyethylene board. Without knife holder. Total height 85 cm. In White (Ref. + B) and Red (Ref. + R)

*F - Billot de 4 pieds en bois (Réf. A) + plaque en polyéthylène de 5 cm*  
*Sans porte couteaux. Hauteur totale 85 cm. Couleurs Blanc (Réf. + B) et Rouge (Réf. + R)*

Ref.	Medida taco Cutting board size Mesure bloc	Euros
V-FA404020PL	40 x 40 x 20 cm	386,00
V-FA454520PL	45 x 45 x 20 cm	454,00
V-FA505020PL	50 x 50 x 20 cm	535,00
V-FA604020PL	60 x 40 x 20 cm	520,00
V-FA644520PL	64 x 45 x 20 cm	603,00
V-FA705020PL	70 x 50 x 20 cm	692,00
V-FA1005020PL	100 x 50 x 20 cm	909,00



**F - Tajo de 4 patas de acero-inox con faldón (Ref. I) con taco de madera fabricado en cuadradillo + 5 cm polietileno**  
**Sin portacuchillos. Altura total 85 cm. En Blanco (Ref + B) y Rojo (Ref + R)**

F - 4 stainless steel legs chopping block table with drawer (Ref. I) + 5 cm polyethylene board. Without knife holder. Total height 85 cm. In White (Ref. + B) and Red (Ref. + R)

*F - Billot de 4 pieds en inox avec jupe (Réf. I) + plaque en polyéthylène de 5 cm*  
*Sans porte couteaux. Hauteur totale 85 cm. Couleurs Blanc (Réf. + B) et Rouge (Réf. + R)*

Ref.	Medida taco Cutting board size Mesure bloc	Euros
V-FI404020PL	40 x 40 x 20 cm	550,00
V-FI454520PL	45 x 45 x 20 cm	617,00
V-FI505020PL	50 x 50 x 20 cm	706,00
V-FI604020PL	60 x 40 x 20 cm	690,00
V-FI644520PL	64 x 45 x 20 cm	796,00
V-FI705020PL	70 x 50 x 20 cm	880,00
V-FI1005020PL	100 x 50 x 20 cm	1238,00



**F - Tajo de 4 patas de acero-inox sin faldón (Ref. I-2) con taco de madera fabricado en cuadradillo + 5 cm polietileno**  
**Sin portacuchillos. Altura total 85 cm. En Blanco (Ref + B) y Rojo (Ref + R)**

F - 4 stainless steel legs chopping block table without drawer (Ref. I-2) + 5 cm polyethylene board. Without knife holder. Total height 85 cm. In White (Ref. + B) and Red (Ref. + R)

*F - Billot de 4 pieds en inox sans jupe (Réf. I-2) + plaque en polyéthylène de 5 cm*  
*Sans porte couteaux. Hauteur totale 85 cm. Couleurs Blanc (Réf. + B) et Rouge (Réf. + R)*

Ref.	Medida taco Cutting board size Mesure bloc	Euros
V-FI2404020PL	40 x 40 x 20 cm	537,00
V-FI2454520PL	45 x 45 x 20 cm	598,00
V-FI2505020PL	50 x 50 x 20 cm	684,00
V-FI2604020PL	60 x 40 x 20 cm	668,00
V-FI2644520PL	64 x 45 x 20 cm	762,00
V-FI2705020PL	70 x 50 x 20 cm	846,00
V-FI21005020PL	100 x 50 x 20 cm	1108,00

**0 1** TAJO DE 4 PATAS CON TACO MADERA Y SOBRE DE POLIETILENO | 4 LEGS WOODEN CHOPPING BLOCK WITH POLYETHYLENE BOARD | *BILLOT EN BOIS DE 4 PIEDS AVEC PLAQUE EN POLYÉTHYLÈNE*



**F - Tajo de 4 patas insonorizado de acero-inox (Ref. S) con taco de madera fabricado en cuadradillo + 5 cm polietileno Sin portacuchillo. Altura total 85 cm. En Blanco (Ref + B) y Rojo (Ref + R)**

F - 4-leg stainless steel sound proof anti-vibration chopping block table (Ref. S) + 5 cm polyethylene board Without knife holder. Total height 85 cm. In White (Ref. + B) and Red (Ref. + R)

*F - Billot avec 4 pieds acier inox insonorisé antivibratoire (Réf. S) + plaque en polyéthylène de 5 cm Sans porte couteaux. Hauteur totale 85 cm. Couleurs Blanc (Réf. + B) et Rouge (Réf. + R)*

Ref.	Medida taco Cutting board size Mesure bloc	Euros
V-FS454520PL	45 x 45 x 20 cm	1350,00
V-FS604020PL	60 x 40 x 20 cm	1485,00
V-FS705020PL	70 x 50 x 20 cm	1694,00

MESAS DE CORTE | CUTTING TABLES | *TABLES DÉCOUPE*



**L-2 - Mesa de madera sin faldón y sobre de polietileno Polietileno 5 cm, altura total 90 cm En Blanco (Ref + B) y Rojo (Ref + R)**

L-2 - Wooden table without drawer and polyethylene board Polyethylene 5 cm, total Height 90 cm. In White (Ref. + B) and Red (Ref. + R)

*L-2 - Table en bois de découpe sans jupe et plaque en polyéthylène Polyéthylène 5 cm, hauteur Totale 90 cm. Couleurs Blanc (Réf. + B) et Rouge (Réf. + R)*

Ref.	Medidas Size Dimensions	Euros
V-L240405	40 x 40 cm	277,00
V-L245455	45 x 45 cm	312,00
V-L250505	50 x 50 cm	349,00
V-L260405	60 x 40 cm	344,00
V-L270505	70 x 50 cm	427,00

**Mesa de madera sin faldón y sobre de polietileno Polietileno 9 cm, altura total 94 cm En Blanco (Ref + B) y Rojo (Ref + R)**

Wooden table without drawer and polyethylene board Polyethylene 9 cm, total Height 94 cm. In White (Ref. + B) and Red (Ref. + R)

*Table en bois de découpe sans jupe et plaque en polyéthylène Polyéthylène 9 cm, hauteur Totale 94 cm. Couleurs Blanc (Réf. + B) et Rouge (Réf. + R)*

Ref.	Medidas Size Dimensions	Euros
V-L240409	40 x 40 cm	382,00
V-L245459	45 x 45 cm	457,00
V-L250509	50 x 50 cm	506,00
V-L260409	60 x 40 cm	492,00
V-L270509	70 x 50 cm	695,00



**K - Mesa de acero-inox con faldón y estante sobre de polietileno**  
**Polietileno 5 cm, altura total 90 cm**  
**En Blanco (Ref + B) y Rojo (Ref + R)**

K - Stainless steel table with drawer and shelf + polyethylene  
 Polyethylene 5 cm, total height 90 cm.  
 In White (Ref. + B) and Red (Ref. + R)

*K - Table d'inox avec jupe et étagère + polyéthylène*  
*Polyéthylène 5 cm, hauteur totale 90 cm.*  
*Couleurs Blanc (Réf. + B) et Rouge (Réf. + R)*

Ref.	Medidas Size Dimensions	Euros
V-K40405	40 x 40 cm	419,00
V-K45455	45 x 45 cm	468,00
V-K50505	50 x 50 cm	495,00
V-K60405	60 x 40 cm	491,00
V-K70505	70 x 50 cm	588,00

**Mesa de acero-inox con faldón y estante sobre de polietileno**  
**Polietileno 9 cm, altura total 94 cm**  
**En Blanco (Ref + B) y Rojo (Ref + R)**

Stainless steel table with drawer and shelf + polyethylene  
 Polyethylene 9 cm, total Height 94 cm.  
 In White (Ref. + B) and Red (Ref. + R)

*Table d'inox avec jupe et étagère + polyéthylène*  
*Polyéthylène 9 cm, hauteur Totale 94 cm.*  
*Couleurs Blanc (Réf. + B) et Rouge (Réf. + R)*

Ref.	Medidas Size Dimensions	Euros
V-K40409	40 x 40 cm	527,00
V-K45459	45 x 45 cm	593,00
V-K50509	50 x 50 cm	649,00
V-K60409	60 x 40 cm	639,00
V-K70509	70 x 50 cm	848,00



**K-5 - Mesa de acero-inox pesada con faldón y estante sobre de polietileno**  
**Polietileno 5 cm, altura total 90 cm**  
**En Blanco (Ref + B) y Rojo (Ref + R)**

K-5 - Stainless steel heavy table with drawer and shelf + polyethylene  
 Polyethylene 5 cm, total height 90 cm.  
 In White (Ref. + B) and Red (Ref. + R)

*K-5 - Table lourd d'inox avec jupe et étagère + polyéthylène*  
*Polyéthylène 5 cm, hauteur totale 90 cm.*  
*Couleurs Blanc (Réf. + B) et Rouge (Réf. + R)*

Ref.	Medidas Size Dimensions	Euros
V-K540405	40 x 40 cm	548,00
V-K545455	45 x 45 cm	598,00
V-K550505	50 x 50 cm	647,00
V-K560405	60 x 40 cm	625,00
V-K570505	70 x 50 cm	747,00

**Mesa de acero-inox pesada con faldón y estante sobre de polietileno**  
**Polietileno 9 cm, altura total 94 cm**  
**En Blanco (Ref + B) y Rojo (Ref + R)**

Stainless steel heavy table with drawer and shelf + polyethylene  
 Polyethylene 9 cm, total Height 94 cm.  
 In White (Ref. + B) and Red (Ref. + R)

*Table lourd d'inox avec jupe et étagère + polyéthylène*  
*Polyéthylène 9 cm, hauteur Totale 94 cm.*  
*Couleurs Blanc (Réf. + B) et Rouge (Réf. + R)*

Ref.	Medidas Size Dimensions	Euros
V-K540409	40 x 40 cm	641,00
V-K545459	45 x 45 cm	723,00
V-K550509	50 x 50 cm	786,00
V-K560409	60 x 40 cm	776,00
V-K570509	70 x 50 cm	1011,00



**MI - Mesa total de acero-inox desmontable con estante**  
**Altura total 85 cm.**

MI - Total stainless steel detachable table with shelf  
 Total height 85 cm.

MI - Table totale d'inox démontable avec étagère  
 Hauteur totale 85 cm.

Ref.	Medidas Size Dimensions	Euros
V-MI10060C	100 x 60 cm	704,00
V-MI10070C	100 x 70 cm	744,00
V-MI15060C	150 x 60 cm	823,00
V-MI15070C	150 x 70 cm	904,00
V-MI20060C	200 x 60 cm	990,00
V-MI20070C	200 x 70 cm	1092,00

**MI - Mesa total de acero-inox desmontable sin estante**  
**Altura total 85 cm.**

MI - Total stainless steel detachable table without shelf  
 Total height 85 cm.

MI - Table totale d'inox démontable sans étagère  
 Hauteur totale 85 cm.

Ref.	Medidas Size Dimensions	Euros
V-MI10060S	100 x 60 cm	665,00
V-MI10070S	100 x 70 cm	695,00
V-MI15060S	150 x 60 cm	761,00
V-MI15070S	150 x 70 cm	826,00
V-MI20060S	200 x 60 cm	929,00
V-MI20070S	200 x 70 cm	1024,00



**Mesa acero-inox para cortadoras 2 estantes**

Stainless steel table for cutters  
 2 shelves

Table inox pour cutters 2  
 étagères

Ref.	Medidas Size Dimensions	Euros
V-MI7050	70 x 50 x 85 cm	580,00



**Mesa acero-inox para sierra 1 estante**

Stainless steel table for saw  
 1 shelf

Table inox pour scie 1 étagère

Ref.	Medidas Size Dimensions	Euros
V-MI5050	50 x 50 x 65 cm	432,00

**Soporte mostrador acero-inox, 2 patas con guías regulables**  
**Altura mínima 80, máxima 88 cm.**

Stainless steel counter support,  
 2 legs with fittable guides  
 Minimum height 80, maximum  
 88 cm.

Support comptoir inox, 2 pattes  
 avec guides réglables  
 Hauteur minimum 80, maximum  
 88 cm.

Ref.	Medidas Size Dimensions	Euros
V-MIS	69 x 49 cm	449,00



**MM - Mesa de acero-inox con sobre mixto sin estante**  
**Con banda de 30 cm de polietileno de 2 cm grosor. Altura total 85**  
**cm. En blanco (X=B) ó rojo (X=R).**

MM - Stainless steel table with mixed top and without shelf  
 With 30 cm polyethylene board of 2 cm thickness. Total height 85 cm.  
 In white (X=B) or red (X=R).

MM - Table acier inox avec surface mixte et sans étagère  
 Table de 30 cm en poléthylène de 2 cm d'épaisseur. Hauteur totale  
 85 cm. En blanc (X=B) ou rouge (X=R).

Ref.	Medidas Size Dimensions	Euros
V-MM10060XS	100 x 60 cm	1255,00
V-MM10070XS	100 x 70 cm	1448,00
V-MM15060XS	150 x 60 cm	1466,00
V-MM15070XS	150 x 70 cm	1666,00
V-MM20060XS	200 x 60 cm	1719,00
V-MM20070XS	200 x 70 cm	1961,00

**MM - Mesa de acero-inox con sobre mixto con estante**  
**Con banda de 30 cm de polietileno de 2 cm grosor. Altura total 85**  
**cm. En blanco (X=B) ó rojo (X=R).**

MM - Stainless steel table with mixed top and shelf  
 With 30 cm polyethylene board of 2 cm thickness. Total height 85 cm.  
 In white (X=B) or red (X=R).

MM - Table acier inox avec surface mixte et étagère  
 Table de 30 cm en poléthylène de 2 cm d'épaisseur. Hauteur totale  
 85 cm. En blanc (X=B) ou rouge (X=R).

Ref.	Medidas Size Dimensions	Euros
V-MM10060XC	100 x 60 cm	1309,00
V-MM10070XC	100 x 70 cm	1513,00
V-MM15060XC	150 x 60 cm	1528,00
V-MM15070XC	150 x 70 cm	1740,00
V-MM20060XC	200 x 60 cm	1799,00
V-MM20070XC	200 x 70 cm	2032,00



**MP - Mesa acero-inox con sobre total de polietileno con estante**  
**Con Sobre total de polietileno de 2 cm de grosor. Altura total 87**  
**cm. En blanco (X=B) ó rojo (X=R).**

MP - Stainless steel table with total polyethylene top with shelf  
 Polyethylene top of 2 cm thickness. Total height 87 cm. In white  
 (X=B) or red (X=R).

MP - Table acier inox avec surface en poléthylène avec étagère  
 Polyéthylène de 2 cm d'épaisseur. Hauteur totale 87 cm. En blanc  
 (X=B) ou rouge (X=R).

Ref.	Medidas Size Dimensions	Euros
V-MP10060XC	100 x 60 cm	1223,00
V-MP10070XC	100 x 70 cm	1448,00
V-MP15060XC	150 x 60 cm	1484,00
V-MP15070XC	150 x 70 cm	1696,00
V-MP20060XC	200 x 60 cm	1755,00
V-MP20070XC	200 x 70 cm	2008,00

**MP - Mesa acero-inox con sobre total de polietileno sin estante**  
**Con Sobre total de polietileno de 2 cm de grosor. Altura total 87**  
**cm. En blanco (X=B) ó rojo (X=R).**

MP - Stainless steel table with total polyethylene top without shelf  
 Polyethylene top of 2 cm thickness. Total height 87 cm. In white  
 (X=B) or red (X=R).

MP - Table acier inox avec surface en poléthylène sans étagère  
 Polyéthylène de 2 cm d'épaisseur. Hauteur totale 87 cm. En blanc  
 (X=B) ou rouge (X=R).

Ref.	Medidas Size Dimensions	Euros
V-MP10060XS	100 x 60 cm	1187,00
V-MP10070XS	100 x 70 cm	1381,00
V-MP15060XS	150 x 60 cm	1417,00
V-MP15070XS	150 x 70 cm	1622,00
V-MP20060XS	200 x 60 cm	1682,00
V-MP20070XS	200 x 70 cm	1922,00



**MX - Mesa de acero-inox económica con sobre total de polietileno con estante**  
**Con sobre total de polietileno de 2 cm de grosor. Altura total 85 cm. En blanco (X=B) ó rojo (X=R).**

MX - Stainless steel economic table with total polyethylene top and shelf  
 Total polyethylene top de 2 cm thickness. Total height 85 cm. In white (X=B) or red (X=R).

MX - Table acier inox économique avec surface en polyéthylène avec étagère  
 Surface en polyéthylène de 2 cm d'épaisseur. Hauteur totale 85 cm. En blanc (X=B) ou rouge (X=R).

Ref.	Medidas Size Dimensions	Euros
V-MX10050XC	100 x 50 cm	826,00
V-MX10060XC	100 x 60 cm	881,00
V-MX10070XC	100 x 70 cm	1024,00
V-MX15050XC	150 x 50 cm	997,00
V-MX15060XC	150 x 60 cm	1066,00
V-MX15070XC	150 x 70 cm	1210,00
V-MX20050XC	200 x 50 cm	1193,00
V-MX20060XC	200 x 60 cm	1271,00
V-MX20070XC	200 x 70 cm	1456,00

**MX - Mesa de acero-inox económica con sobre total de polietileno sin estante**  
**Con sobre total de polietileno de 2 cm de grosor. Altura total 85 cm. En blanco (X=B) ó rojo (X=R).**

MX - Stainless steel economic table with total polyethylene top and without shelf  
 Total polyethylene top de 2 cm thickness. Total height 85 cm. In white (X=B) or red (X=R).

MX - Table acier inox économique avec surface en polyéthylène avec sans étagère  
 Surface en polyéthylène de 2 cm d'épaisseur. Hauteur totale 85 cm. En blanc (X=B) ou rouge (X=R).

Ref.	Medidas Size Dimensions	Euros
V-MX10050XS	100 x 50 cm	767,00
V-MX10060XS	100 x 60 cm	825,00
V-MX10070XS	100 x 70 cm	957,00
V-MX15050XS	150 x 50 cm	886,00
V-MX15060XS	150 x 60 cm	955,00
V-MX15070XS	150 x 70 cm	1087,00
V-MX20050XS	200 x 50 cm	1030,00
V-MX20060XS	200 x 60 cm	1108,00
V-MX20070XS	200 x 70 cm	1235,00

**ARTÍCULOS MESA POLIETILENO PE 500 | POLYETHYLENE TABLE ARTICLES | ACCESOIRES DE CUISINE EN POLYÉTHYLÈNE**



**Tabla canal recoge-jugos**  
**En Blanco (Ref + B) y Rojo (Ref + R)**

Cutting board with juice canal  
 In White (Ref. + B) and Red (Ref. + R)

Planche avec canal pour garder le jus  
 Couleurs Blanc (Réf. + B) et Rouge (Réf. + R)

Ref.	Medidas Size Dimensions	Euros
V-HC3320	33 x 20 x 1,5	24,70
V-HC5020	50 x 20 x 1,5	39,00
V-HC10020	100 x 20 x 1,5	61,00

**Plato pulpo**

Octopus plate

Assiette poulpe

Ref.	Diámetro Diameter	Altura Height	Euros
A-48-18	Ø 18 cm	2 cm	22,00
A-48-22	Ø 22 cm	2 cm	28,00
A-48-26	Ø 26 cm	2 cm	36,00



**Tabla ranuras pan, salmón**

Bread utting board, salmon

Planche pour couper le pain, saumon

Ref.	Medidas Size Dimensions	Euros
V-HRP-40302S	40 x 30 x 2 cm	49,50



**Mano para colador chino**

Handle for placing cone strainer 45 cm

Triangle pour passoire chinois 45 cm

Ref.	Euros
A-42	35,00



**Triángulo para colador chino 45 cm**

Triangle for placing cone strainer 45 cm

Triangle pour passoire chinois 45 cm

Ref.	Euros
A-41	36,00



**Mortero sin mano**

Mortar

Mortier

Ref.	Diámetro Diameter Diamètre	Euros
A-43	Ø 18 cm	90,00
A-43-P	Ø 14 cm	65,00



**Mano mortero A-43**

Pestle for A-43

Pilon pour mortier A-43

Ref.	Medidas Size Dimensions	Euros
A-44	20 x 5 cm	19,00
A-44-P	18,5 x 4,5 cm	17,00

**Rodillo amasador**

Dough roller

Rouleau à pâtisserie

Ref.	Diámetro Diameter Diamètre	Largo Long Longueur	Euros
A-46	Ø 5 cm	50 cm	46,00
A-47	Ø 6 cm	60 cm	54,00





**Maza para picar hielo Polietileno + Inox.**

Mace ice crushing Polietileno + Inox.

Glace pilée maza Polietileno + Inox.

Ref.	Medidas Size Dimensions	Euros
A-57	6 x 6 x 10 cm	24,50

**PALAS POLIETILENO | POLYETHYLENE SLICES | PALLES EN POLYÉTHYLÈNE**

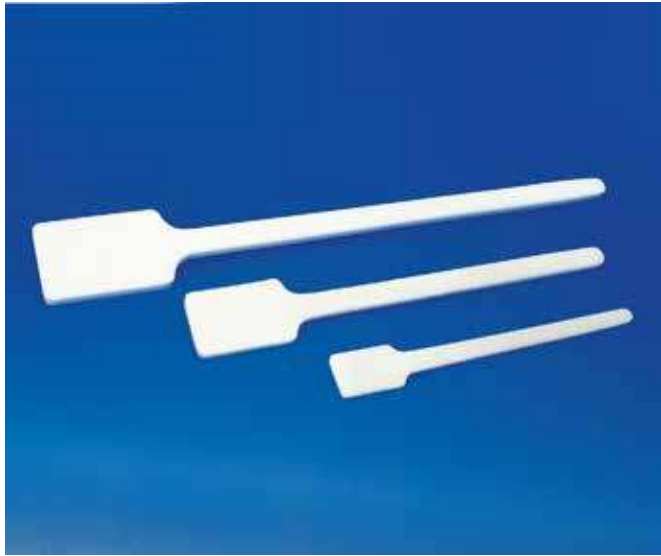

**Pala polietileno**

Polyethylene slice

Palle en polyéthylène

Ref.	Largo Long Longueur	Euros
A-30-50	50 cm	16,00
A-30-70	70 cm	24,00
A-30-100	100 cm	34,00



**Pala polietileno + inox**

Polyethylene slice + stainless steel

Palle en polyéthylène + inox

Ref.	Largo Long Longueur	Euros
A-30-50-I	50 cm	46,00
A-30-70-I	70 cm	54,00
A-30-100-I	100 cm	76,00

**SOPORTE TABLAS POLIETILENO | POLYETHYLENE BOARDS STAND | SUPPORT PLAQUES POLIÉTHYLÈNE**



**Soporte tabla polietileno acero-inox (máx. grueso 3 cm)**

Stainless steel polyethylene board support

Support plaque polyéthylène acier inox

Ref.	Euros
SPI-6	44,00





**Soporte polietileno**

Polyethylene stand

Support polyéthylène

Ref.	Medidas Size Dimensions	Color Colour Couleur	Euros
V-SP2B	27 x 19 x 3 cm	○	38,50
V-SP2R	27 x 19 x 3 cm	●	38,50

**Soporte polietileno marmóreo**

Marble imitation polyethylene stand

Support polyéthylène marbre

Ref.	Medidas Size Dimensions	Euros
V-SP2M	27 x 19 x 3 cm	38,50



**Tabla corte con cubeta**  
**Con guías para cubeta gastronorm GI-1/2-65. Altura 10 cm**

Cuvette cutting board  
With gastronorm tray guides GI-1 / 2-65.  
Height 10 cm

Planche à découper cuvette  
Avec guides de plateaux gastronorm GI-1 / 2-65. Hauteur 10 cm

Ref.	Medidas Size Dimensions	Euros
V-HG40302V	40 x 30 x 2 cm	88,00



**Tabla madera presentación**  
**Con dos listones inferiores**

Wood presentation table  
With two lower slats

Table de présentation en bois  
Avec deux lattes inférieures

Ref.	Medidas Size Dimensions	Euros
V-TP30202	30 x 20 x 2 cm	35,00
V-TP35252	35 x 25 x 2 cm	49,00



**Mesa cocina madera**  
**Con dos estantes y cuatro ruedas giratorias con freno. Altura 90 cm**

Wood kitchen table  
With two shelves and four rotating wheels  
with brake. Height 90 cm

Table de cuisine en bois  
Avec deux étagères et quatre roues en  
rotation avec frein. Hauteur 90 cm

Ref.	Medidas Size Dimensions	Euros
V-MC60505-R	60 x 50 x 5 cm	570,00

**Mesa cocina madera**  
**Con dos estantes. Altura 90 cm**

Wood kitchen table  
With two shelves. Height 90 cm

Table de cuisine en bois  
Avec deux étagères. Hauteur 90 cm

Ref.	Medidas Size Dimensions	Euros
V-MC60505	60 x 50 x 5 cm	481,00



0

2

**Carteles portaprecios, Peana - PLataformas -  
Pinzas, Listas de precios, Carteles señalización,  
Guirnaldas, Separadores, Barreños, Base  
rodante, Cubetas, Bandejas, Gastronorm,  
PlexiLine.**

---

Price tag holder, Stand - platforms - Clips, Price  
lists, Sign, Garlands, Separators, Tubs, Rolling  
base, Containers, Trays, Gastronorm, PlexiLine.

---

*Affiches porte prix, Socle - plate-formes - clips,  
Liste prix, Affiches signalization, Guirlandes,  
Séparateurs, Bassines, Base roulante, Bacs,  
Plateaux, Gastronorm, PlexiLine.*

**21 - 62**



**Porcino, num. relieve, con base**

Pork, num. relief, with base

*Porcin, num. relief, avec base*

Ref.	Medidas Size Dimensions	Unidades Units Unités	Euros
C-300	8,5 x 6,5	12	70,00



**Ternera, num. relieve, con base**

Veal, num. relief, with base

*Veau, num. relief, avec base*

Ref.	Medidas Size Dimensions	Unidades Units Unités	Euros
C-301	8,5 x 6,5	12	70,00



**Cordero, num. relieve, con base**

Lamb, num. relief, with, base

*Agneau, num. relief, avec base*

Ref.	Medidas Size Dimensions	Unidades Units Unités	Euros
C-302	8,5 x 6,5	12	70,00



**Pollo, num. relieve, con base**

Chicken, num. relief, with base

*Poulet, num. relief, avec base*

Ref.	Medidas Size Dimensions	Unidades Units Unités	Euros
C-303	8,5 x 6,5	12	70,00



**Charcutería, num. relieve, con base**

Charcuterie, num. relief, with base

*Charcuterie, num. relief, avec base*

Ref.	Medidas Size Dimensions	Unidades Units Unités	Euros
C-304	8,5 x 6,5	12	70,00



**Quesos, num. relieve, con base**

Cheeses, num. relief, with base

*Fromages, num. relief, avec base*

Ref.	Medidas Size Dimensions	Unidades Units Unités	Euros
C-305	8,5 x 6,5	12	70,00



**Liso Pizarra**

Plane board

*Tableau lisse*

Ref.	Medidas Size Dimensions	Unidades Units Unités	Euros
C-307	8,5 x 6,5 cm	12	70,00



**Panadería/Pastelería, num. relieve, con base**

Bakery/Pastry, num. relief, with base

*Boulangerie/Pâtisserie, num. relief, avec base*

Ref.	Medidas Size Dimensions	Unidades Units Unités	Euros
C-306	8,5 x 6,5	12	70,00



**Porcino, num. relieve, con base**

Pork, num. relief, with base

*Porcin, num. relief, avec base*

Ref.	Medidas Size Dimensions	Unidades Units Unités	Euros
C-310	10,5 x 7,5	12	73,00



**Ternera, num. relieve, con base**

Veal, num. relief, with base

*Veau, num. relief, avec base*

Ref.	Medidas Size Dimensions	Unidades Units Unités	Euros
C-311	10,5 x 7,5	12	73,00



**Cordero, num. relieve, con base**

Lamb, num. relief, with base

*Agneau, num. relief, avec base*

Ref.	Medidas Size Dimensions	Unidades Units Unités	Euros
C-312	10,5 x 7,5	12	73,00



**Pollo, num. relieve, con base**

Chicken, num. relief, with base

*Poulet, num. relief, avec base*

Ref.	Medidas Size Dimensions	Unidades Units Unités	Euros
C-313	10,5 x 7,5	12	73,00



**Charcutería, num. relieve, con base**

Charcutería, num. relieve, with base

*Charcuterie, num. relief, avec, base*

Ref.	Medidas Size Dimensions	Unidades Units Unités	Euros
C-314	10,5 x 7,5	12	73,00



**Quesos, num. relieve, con base**

Cheeses, num. relief, with base

*Fromages, num. relief, avec base*

Ref.	Medidas Size Dimensions	Unidades Units Unités	Euros
C-315	10,5 x 7,5	12	73,00



**Liso pizarra**

Plane board

*Tableau lisse*

Ref.	Medidas Size Dimensions	Unidades Units Unités	Euros
C-317	10,5 x 7,5 cm	12	73,00



**Frutas, nº relieve, con ganchos**

Fruits, num. relief, with hooks

*Fruits, num. relief, avec crochets*

Ref.	Medidas Size Dimensions	Unidades Units Unités	Euros
C-320	13 x 9,5	12	76,00

**Material Glaspar, con pincho acero-inoxidable, arandela de plástico y remaches de plástico**

Made on Glaspar material, spike of Stainless Steel, plastic round base and Plastic rivets

*Matériel Glaspar, pique en acier Inox, rondelle plastique et rivets plastiques*



**Nº ruedas, fondo rojo**

Num. rotating, red deep

*Num. roulette, fond rouge*

Ref.	Medidas Size Dimensions	Unidades Units Unités	Euros
C-10	8 x 7	12	28,50



**Nº ruedas 8x7 fondo azul**

Num rotating 8x7 cm blue deep

*Num. roulettes 8x7 cm fond bleu*

Ref.	Medidas Size Dimensions	Unidades Units Unités	Euros
C-10-AZ	8 x 7	12	28,50



**Nº ruedas, fondo blanco**

Num. rotating, white deep

*Num. roulettes, fond blanc*

Ref.	Medidas Size Dimensions	Unidades Units Unités	Euros
C-10-B	8 x 7	12	28,50



**Nº ruedas 10x7,5 cm. fondo rojo**

Num. rotating 10x7,5 cm. red deep

*Num. roulettes 10x7,5 fond rouge*

Ref.	Medidas Size Dimensions	Unidades Units Unités	Euros
C-11	10 x 7,5	12	29,50



**Nº ruedas, fondo azul**

Num. rotating, blue deep

*Num. roulettes, fond bleu*

Ref.	Medidas Size Dimensions	Unidades Units Unités	Euros
C-11-AZ	10 x 7,5	12	29,50



**Nº ruedas, fondo blanco**

Num. rotating, white deep

*Num. roulettes, fond blanc*

Ref.	Medidas Size Dimensions	Unidades Units Unités	Euros
C-11-B	10 x 7,5	12	29,50



**Nº ruedas, rojo, con rueda para indicar kg-unidades-100gr. - 1/4**

Num. rotating, red, wheel for kilo-unit - 100 gr. - 1/4

*Nº roulettes, rouge, roulette pour kilo-unité, 100 gr. - 1/4*

Ref.	Medidas Size Dimensions	Unidades Units Unités	Euros
C-65-R	11 x 7,5	12	34,00



**Nº ruedas, azul, con rueda para indicar kilo-unid. -100 gr., 1/4**

Num. rotating, blue, wheel for kilo-unit - 100 gr. - 1/4

*Nº roulettes, pré, roulette pour kilo-unité - 100 gr. - 1/4*

Ref.	Medidas Size Dimensions	Unidades Units Unités	Euros
C-65-AZ	11 x 7,5	12	34,00



**Nº ruedas, verde, con rueda para indicar kilo-unidad - 100 gr. - 1/4**

Num. rotating, green, wheel for kilo-unit-100 gr. - 1/4

*Num. roulettes, vert, roulette pour kilo-unité-100 gr. - 1/4*

Ref.	Medidas Size Dimensions	Unidades Units Unités	Euros
C-65-V	11 x 7,5	12	34,00



**Nº ruedas, blanco, con rueda para indicar kilo-unid.- 100 gr. - 1/4**

Num. rotating, white, wheel for kilo-unit - 100 gr. - 1/4

Num. roulettes, white, roulette pour kilo-unité - 100 gr. - 1/4

Ref.	Medidas Size Dimensions	Unidades Units Unités	Euros
C-65-B	11 x 7,5	12	34,00



**Nº ruedas, naranja**

Num. rotating orange

Num. roulettes fond rouge orange

Ref.	Medidas Size Dimensions	Unidades Units Unités	Euros
C-15-N	13 x 10 v	12	38,00



**Nº ruedas**

Num. rotating

Nº roulettes

Ref.	Medidas Size Dimensions	Unidades Units Unités	Euros
C-17	11 x 7,5	12	30,50



**Nº ruedas - Pescadero normativa**

Num. rotating - Fish regulations

Num. roulettes - Poisson regulations

Ref.	Medidas Size Dimensions	Unidades Units Unités	Euros
C-24	13 x 9	12	49,50



**Nº ruedas - Pescadero normativa - Con base**

Num. rotating - Fish regulations

Num. roulettes - Poisson regulations

Ref.	Medidas Size Dimensions	Unidades Units Unités	Euros
C-24-B	12 x 8	12	56,00



**Nº ruedas - Pescadero normativa - Portatarjeta**

Num. rotating - Fish regulations

Nº roulettes - Poisson regulations

Ref.	Medidas Size Dimensions	Unidades Units Unités	Euros
C-24-T	12 x 8	12	66,50



**Pescadería, nº relieve, con base**

Fish, num.relief, with base

Poisson, num. relief, avc base

Ref.	Medidas Size Dimensions	Unidades Units Unités	Euros
C-321	13 x 9,5 cm	12	76,00



**Nº ruedas, prado, Rueda para indicar kilo-unid. - 100 gr. - 1/4**

Num. rotating, Meadow, with wheel for kilo-unit-100 gr - 1/4

Num roulettes, Pré, roulette pour kilo-unité-100 gr. - 1/4

Ref.	Medidas Size Dimensions	Unidades Units Unités	Euros
C-38	11 x 7,5	12	43,50



**Nº ruedas, pergamino, con rueda para indicar kilo-unidad - 100 gr. - 1/4**

Num. rotating, scroll, with wheel for kilo-unit - 100gr. - 1/4

Num. roulettes, parchemin, roulette pour kilo-unité - 100 gr. - 1/4

Ref.	Medidas Size Dimensions	Unidades Units Unités	Euros
C-66	11 x 7,5	12	36,00



**Nº ruedas, pergamino**

Num. rotating, scroll

Num. roulettes, fond rouge parchemin

Ref.	Medidas Size Dimensions	Unidades Units Unités	Euros
C-13	13 x 10	12	40,00



**Nº ruedas, 3+2 dígitos fondo blanco**

Num. rotating, 3+2 digits white deep

Num. roulette, 3+2 chiffres - fond blanc

Ref.	Medidas Size Dimensions	Unidades Units Unités	Euros
C-90-B	13 x 8	12	40,00



**Nº ruedas, 3+2 dígitos fondo azul**

Num. rotating, 3+2 digits blue deep

Num. roulette, 3+2 chiffres - fond bleu

Ref.	Medidas Size Dimensions	Unidades Units Unités	Euros
C-90-AZ	13 x 8	12	40,00



**Nº ruedas, 3+2 dígitos fondo rojo**

Num. rotating, 3+2 digits red deep

Num. roulette, 3+2 chiffres - fond rouge

Ref.	Medidas Size Dimensions	Unidades Units Unités	Euros
C-90-R	13 x 8	12	40,00

**CARTELES PORTAPRECIOS BASE | BASE PRICE TAG HOLDER | AFFICHES PORTE PRIX BASE**

**Material Glaspar, con pincho acero-inoxidable, arandela de plástico y remaches de plástico**

Made on Glaspar material, spike of stainless steel, plastic round base and plastic rivets

Matériel Glaspar, pique en acier inox, rondelle plastique et rivets plastiques



**Porta tarjeta transparente con base**

Transparent card holder with base

Porte-carte transparent avec base

Ref.	Medidas Size Dimensions	Unidades Units Unités	Euros
C-132	9,5 x 7	12	23,50



**Cartel doble cara liso**

Two-faced tag plane

Affiche de double face lisse

Ref.	Medidas Size Dimensions	Unidades Units Unités	Euros
C-140	7 x 6	12	23,50



**Cartel doble cara liso**

Two-faced tag plane

Affiche de double face lisse

Ref.	Medidas Size Dimensions	Unidades Units Unités	Euros
C-141	12 x 8	12	31,50





**Nº ruedas, azul con rueda para indicar kilo-unid. - 100 gr. - 1/4, con base**

Num. rotating, blue, with wheel for kilo-unit-100 gr.-1/4, with base

*Num. roulettes, bleu, avec roulette pour kilo-unit-100 gr.-1/4, avec base*

Ref.	Medidas Size Dimensions	Unidades Units Unités	Euros
C-65-AZB	11 x 7,5	9	42,00



**Nº ruedas, rojo con rueda para indicar kilo-unid. - 100 gr. - 1/4**

Num. rotating, red, with wheel for kilo-unit - 100 gr. - 1/4

*Num. roulettes, rouge, avec roulette pour kilo-unité - 100 gr. - 1/4*

Ref.	Medidas Size Dimensions	Unidades Units Unités	Euros
C-65-RB	11 x 7,5	12	42,00



**Nº ruedas verde, con rueda para indicar Kg-unid.-100 gr.-1/4, con base**

Num. rotating, green, 11x7,5 cm., con rueda para indicar Kg.-unid.-100 gr.-1/4, with base

*Num. roulettes, vert, avec roulette pour Kg.-unit-100 gr.-1/4, avec base*

Ref.	Medidas Size Dimensions	Unidades Units Unités	Euros
C-65-VB	11 x 7,5	12	42,00



**Nº ruedas, blanco, con rueda para indicar kilo-unid.- 100 gr. - 1/4**

Num. rotating, white, 11x7,5 cm., wheel for kilo-unit - 100 gr. - 1/4

*Num. roulettes, white, 11x7,5 cm., roulette pour kilo-unité - 100 gr. - 1/4*

Ref.	Medidas Size Dimensions	Unidades Units Unités	Euros
C-65-BB	11 x 7,5	12	42,00



**Nº ruedas, pergamino, con rueda para indicar Kg-unid.-100 gr.-1/4, con base**

Num. rotating, scroll, with wheel for kilo-unit-100 gr.- 1/4, with base

*Num. roulettes, parchemin, avec roulette pour kilo-unité-100 gr.-1/4, avec base*

Ref.	Medidas Size Dimensions	Unidades Units Unités	Euros
C-66-B	11 x 7,5	12	43,50



**Nº ruedas, con plataforma panadería-pastelería**

Num. rotating, bakery

*Num. roulettes, boulangerie*

Ref.	Medidas Size Dimensions	Unidades Units Unités	Euros
C-67	8,5 x 6,5	12	31,50



**Nº ruedas, con plataforma, azul**

Num. rotating, with base, blue

*Num. roulettes, avec base, bleu*

Ref.	Medidas Size Dimensions	Unidades Units Unités	Euros
C-67-AZ	8,5 x 6,5	12	31,50



**Nº ruedas, con plataforma, rojo**

Num. rotating, red, with base

*Num. roulettees, rouge, avec base*

Ref.	Medidas Size Dimensions	Unidades Units Unités	Euros
C-67-R	8,5 x 6,5	12	31,50



**Nº ruedas, prado con rueda para indicar Kg-unid. - 100 gr. - 1/4, con base**

Num. rotating, meadow, kilo-unit-100 gr. - 1/4, with base

*Num. roulettes, pré, kilo-unité-100 gr.- 1/4, avec base*

Ref.	Medidas Size Dimensions	Unidades Units Unités	Euros
C-38-B	11 x 7,5	12	51,00



**Liso con base**

Plane with base

*Lisse avec base*

Ref.	Medidas Size Dimensions	Unidades Units Unités	Euros
C-7-B	10 x 7	12	30,50

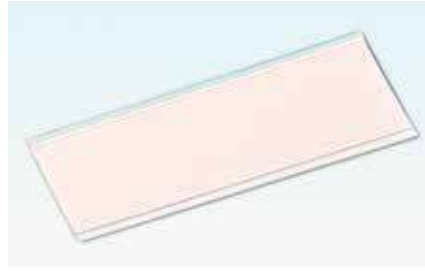

**Guía adhesiva para etiquetas, transparente**

Transparent adhesive label holder

*Tringle adhésive transparent pour étiquettes*

Ref.	Medidas Size Dimensions	Unidades Units Unités	Euros
C-130	10 x 4	12	11,00

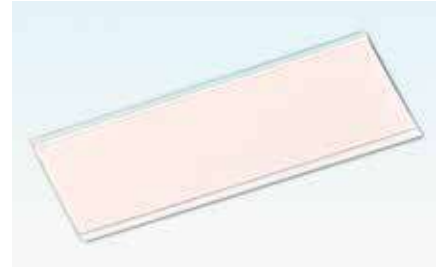

**Guía adhesiva para etiquetas, 100x4 cm, transparente**

Transparent adhesive label holder, 100x4 cm

*Tringle adhésive transparent pour étiquettes, 100x4 cm*

Ref.	Euros
C-131	9,00

**CARTELES PORTAPRECIOS LISOS-DIGITAL | SMOOTH LABELED DIGITAL PRICE TAG HOLDERS | AFFICHES PORTE PRIX LISSE-DIGITAL**

**Material: Glaspar, Pincho: Acero-inox, Arandela: Plástico, Remaches:Plástico**

Material: Glaspar, Spike: Stainless Steel, Round base: Plastic, Rivets: Plastic

*Matériel: Glaspar, Pique: Acier inox, Rondelle: Plastique, Rivets: Plastique*



**Nº digital fondo azul**

Num. digital blue deep

*Num. digital fond bleu*

Ref.	Medidas Size Dimensions	Unidades Units Unités	Euros
C-91	11 x 8	12	23,50



**Nº digital fondo rojo**

Num. digital red deep

*Num. digital fond bleu*

Ref.	Medidas Size Dimensions	Unidades Units Unités	Euros
C-92	11 x 8	12	23,50



**Liso pizarra con pincho**

Smooth slate with skewerSmooth slate with skewer

*Ardoise lisse avec pin*

Ref.	Medidas Size Dimensions	Unidades Units Unités	Euros
C-97	8,5 x 6,5 cm	12	16,00
C-98	15,5 x 9 cm	12	23,50



**Liso pizarra sin pincho**

Smooth slate with skewerSmooth slate without skewer

*Ardoise lisse sans pin*

Ref.	Medidas Size Dimensions	Unidades Units Unités	Euros
C-97-N	8,5 x 6,5 cm	12	16,00
C-98-N	15,5 x 9 cm	12	23,50



**Dorado rectangular**

Golden rectangular

*Rectangulaire dorée*

Ref.	Medidas Size Dimensions	Unidades Units Unités	Euros
C-81	6 x 4	12	10,00



**Dorado oval**

Golden oval

*Ovale dorée*

Ref.	Medidas Size Dimensions	Unidades Units Unités	Euros
C-82	5 x 4	12	10,00



**Visera oferta para carteles ruedas**

Offer top for rotating tags

Visière d'offre pour affiches roulettes

Ref.	Unidades Units Unités	Euros
C-2	12	17,00



**Nº digital fondo dorado**

Num. digital golden deep

Num. digital fond doré

Ref.	Medidas Size Dimensions	Unidades Units Unités	Euros
C-99	11 x 8	12	23,50



**Liso Panadería-Pastelería**

Plane bakery/Pâtisserie

Lisse Boulangerie/Pâtisserie

Ref.	Medidas Size Dimensions	Unidades Units Unités	Euros
C-39	8,5 x 6	12	19,00



**Liso**

Plane

Lisse

Ref.	Medidas Size Dimensions	Unidades Units Unités	Euros
C-7	10 x 7	12	23,50



**Rotulador para carteles digitales y rotulación producto**

Marker for digital tags and product signages

Marqueur pour les affiches digitales et marquages de produits

Ref.	Euros
C-100	4,20



**Inyección con guía para etiqueta, masa roja**

Injection with place to fit label, red  
Material : injected plastic

Stainless steel pin

Injection avec tringle pour étiquette, rouge  
Matériel: plastique injecté

Pique : acier inox.

Ref.	Medidas Size Dimensions	Unidades Units Unités	Euros
C-42-GR	10 x 7	12	45,50

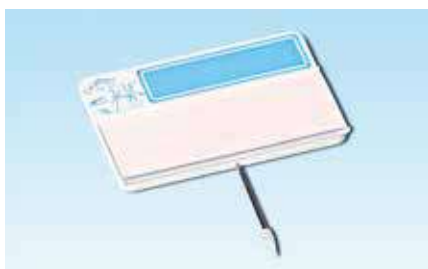

**Inyección con guía para etiqueta, masa azul**

Injection with place to fit label, 10x7 cm, blue

Injection avec tringle pour étiquette, 10x7 cm, bleu

Ref.	Medidas Size Dimensions	Unidades Units Unités	Euros
C-42-GAZ	10 x 7	12	45,50



**Inyección con guía para etiqueta, blanco**

Injection with place to fit label, white

Injection avec tringle pour étiquette, blanc

Ref.	Medidas Size Dimensions	Unidades Units Unités	Euros
C-42-G	10 x 7	12	45,50



**Inyección con guía para etiqueta, masa marrón**

Injection with place to fit label, brown

Injection avec tringle pour étiquette, marron

Ref.	Medidas Size Dimensions	Unidades Units Unités	Euros
C-42-GM	10 x 7	12	45,50

**Material : Plástico inyectado - Pincho : Acero inox. - Números : Relieve**

Material: Injected Plastic - Pin: Stainless Steel - Numbers: Relief

Matériel : Plastique injecté - Pique: Acier inox. - Chiffres: Relief



**Inyección, N° relieve, azul**

Injection, num. relief, blue

*Injection, num. relief, bleu*

Ref.	Medidas Size Dimensions	Unidades Units Unités	Euros
C-44-AZ	9 x 7,5	24	105,00



**Inyección, N° relieve, blanco**

Injection, num. relief, white

*Injection, num. relief, blanc*

Ref.	Medidas Size Dimensions	Unidades Units Unités	Euros
C-44-B	9 x 7,5	24	105,00



**Inyección, N° relieve, crema**

Injection, num. relief, beige

*Injection, num. relief, beige*

Ref.	Medidas Size Dimensions	Unidades Units Unités	Euros
C-44-C	9 x 7,5	24	105,00



**Inyección, N° relieve, marrón**

Injection, num. relief, brown

*Injection, num. relief, marron*

Ref.	Medidas Size Dimensions	Unidades Units Unités	Euros
C-44-M	9 x 7,5	24	105,00



**Inyección, N° relieve, rojo**

Injection, num. relief, red

*Injection, num. relief, rouge*

Ref.	Medidas Size Dimensions	Unidades Units Unités	Euros
C-44-R	9 x 7,5	24	105,00



**Inyección, N° relieve, blanco masa azul**

Injection, N° relief, white blue top

*Injection, num. relief, blanc tête bleu*

Ref.	Medidas Size Dimensions	Unidades Units Unités	Euros
C-44-BAZ	9 x 7,5	24	105,00



**Inyección, N° relieve, blanco masa rojo**

Injection, num. relief, 9x7,5 cm, white red top

*Injection, num. relief, 9x75, blanc tête rouge*

Ref.	Medidas Size Dimensions	Unidades Units Unités	Euros
C-44-BR	9 x 7,5	24	105,00



**Inyección, N° relieve, blanco masa verde**

Injection, num. relief, white and green top

*Injection, num. relief, blanc et tête vert*

Ref.	Medidas Size Dimensions	Unidades Units Unités	Euros
C-44-BV	9 x 7,5	24	105,00



**Inyección, N° relieve, azul**

Injection, num. relief, blue  
Material: Injected Plastic - Pin: Stainless Steel - Numbers: Relief

*injection, num. relief, bleu*

Ref.	Medidas Size Dimensions	Unidades Units Unités	Euros
C-42-AZ	10 x 7	24	93,00



**Inyección, Nº relieve, blanco**

Injection num. relief, white

*Injection, num. relief, blanc*

Ref.	Medidas Size Dimensions	Unidades Units Unités	Euros
C-42-B	10 x 7	24	93,00



**Inyección, Nº relieve, crema**

Injection num. relief, beige

*Injection, num. relief beige*

Ref.	Medidas Size Dimensions	Unidades Units Unités	Euros
C-42-C	10 x 7	24	93,00



**Inyección, Nº relieve, masa roja**

Injection, num. relief, red

*Injection, num. relief, rouge*

Ref.	Medidas Size Dimensions	Unidades Units Unités	Euros
C-42-R	10 x 7	24	93,00



**Inyección, Nº relieve, masa green**

Injection, num. relief, green

*Injection, Nº relief, vert*

Ref.	Medidas Size Dimensions	Unidades Units Unités	Euros
C-42-V	10 x 7	24	93,00



**Visera oferta para acoplar a ref. C-44**

Offer top for fitting on item C-44

*Visière d'offre pour réf. C-44*

Ref.	Unidades Units Unités	Euros
C-43	12	22,50



**Arandela para acoplar ref. C-44**

Washer for coupling C-44

*Rondelle pour raccorder C-44*

Ref.	Unidades Units Unités	Euros
C-43-A	12	6,00

**ROTULACIÓN | SIGNAGES | MARQUAGES**



**Rotulación cartel indicando producto**

Tag signage, product indication

*Marquage d'affiche, indication de produit*

Ref.	Euros
C-51	0,85



**Grabado C-42 - C-44**

Signage C-42 - C-44

*Marquage C-42 - C-44*

Ref.	Euros
C-56	1,60

Material: Glaspar - Paleta: Inyección - Ganchos: Acero-Inox - Números : Recambiables - Ruedas

Material: Glaspar - Spatula: Injection - Hangers: Stainless Steel - Numbers: changeable - Wheels  
 Matériel: Glaspar - Palette: Injection - Crochets: Acier Inox. - Chiffres: interchangeable - Roulettes



Frutas, nº relieve, con ganchos

Fruits, num. relief, with hooks

Fruits, num. relief, avec crochets

Ref.	Medidas Size Dimensions	Unidades Units Unités	Euros
C-320	13 x 9,5 cm	12	76,00



Oferta, Nº recambiable

Offer, Num. interchangeable

Offre, Num. interchangeable

Ref.	Medidas Size Dimensions	Unidades Units Unités	Euros
C-34	28 x 23,5	6	45,50



Oferta, Nº recambiable

Offer, Num. interchangeable

Offre, Num. interchangeable

Ref.	Medidas Size Dimensions	Unidades Units Unités	Euros
C-35	18 x 12,5	12	51,00



Oferta kilos, Nº recambiable

Kilo offer, Num. interchangeable

Offre kilo, Num. interchangeable

Ref.	Medidas Size Dimensions	Unidades Units Unités	Euros
C-35-K	18 x 12,5	12	55,00



Nº recambiable, Paleta

Num. interchangeable, Palette

Num. interchangeable, Palette

Ref.	Medidas Size Dimensions	Unidades Units Unités	Euros
C-40	19 x 13	12	52,50



Nº recambiable, Ganchos

Num. interchangeable, Hooks

Num. interchangeable, Crochets

Ref.	Medidas Size Dimensions	Euros
C-41	19 x 13	52,50



Nº ruedas, Verde, con rueda para indicar kilo - Unid. 100 grs - 1/4

Num. rotating, Green, Wheel for kilo or unit

Num. roulettes, Vert, Roulette pour kilo ou unité

Ref.	Medidas Size Dimensions	Unidades Units Unités	Euros
C-65-VF	11 x 7,5	12	36,00



Nº recambiable, 4 dígitos, Paleta

Num. interchangeable, 4 digits, Palette

Num. interchangeable, 4 digits, Palette

Ref.	Medidas Size Dimensions	Unidades Units Unités	Euros
C-68	18,5 x 12	12	51,50



Num. recambiable, 4 dígitos, Ganchos

Nº interchangeable, 4 digits, Hooks

Nº interchangeable, 4 digits, Crochets

Ref.	Medidas Size Dimensions	Unidades Units Unités	Euros
C-69	18,5 x 12	12	51,50



**Nº ruedas, 4 dígitos, Paleta**

Num. rotating, 4 digits, Palette

*Num. roulettes, 4 digits, Palette*

Ref.	Medidas Size Dimensions	Unidades Units Unités	Euros
C-72	18 x 11	12	57,00



**Nº ruedas, 4 dígitos, 2 Ganchos**

Num. rotating, 4 digits, 2 hooks

*Num. roulettes, 4 digits, 2 crochets*

Ref.	Medidas Size Dimensions	Unidades Units Unités	Euros
C-73	18 x 11	12	57,00



**Oferta kilos, Nº recambiable, Paleta**

Kilo offer, Num. interchangeable, Palette

*Offre kilo, Nº interchangeable, Palette*

Ref.	Medidas Size Dimensions	Unidades Units Unités	Euros
C-74	23,5 x 18,5	6	51,50



**Oferta kilos, Nº recambiable, Ganchos,**

Kilo offer, Num. interchangeable, Hooks,

*Kilo offer, Num. interchangeable, Crochets*

Ref.	Medidas Size Dimensions	Unidades Units Unités	Euros
C-75	23 x 18,5	6	51,50



**Nº ruedas, Paleta**

Num. rotating, Palette

*Num. rotating, Palette*

Ref.	Medidas Size Dimensions	Unidades Units Unités	Euros
C-76	22 x 14	12	55,00



**Frutas, Nº ruedas, Paleta**

Fruits, Nº rotating, Palette

*Fruits, Nº roulettes, Palette*

Ref.	Medidas Size Dimensions	Unidades Units Unités	Euros
C-76-C	22 x 14	12	55,00



**Nº ruedas, Paleta, con num. tecla**

Num. rotating, Palette, with product ref.

*Num. roulettes, Palette, avec réf. du produit*

Ref.	Medidas Size Dimensions	Unidades Units Unités	Euros
C-76-T	22 x 14	12	67,50



**Nº ruedas, Ganchos, con Nº tecla**

Num. rotating, Hooks, with product ref.

*Num. roulettes, Palette, avec réf. du produit*

Ref.	Unidades Units Unités	Euros
C-77-T	12	67,50



**Nº ruedas, Ganchos**

Num. rotating, Hooks, Palette

*Num. roulettes, Crochets*

Ref.	Medidas Size Dimensions	Unidades Units Unités	Euros
C-77	22 x 14	12	55,00

**Frutas, N° ruedas, Ganchos**

Fruits, Num. rotating, Hooks

*Fruits, Num. roulettes, Crochets*

Ref.	Unidades Units Unités	Euros
C-77-C	12	55,00

**Liso pizarra, Paleta**

Plane Board, Palette

*Num. roulettes, Crochets, Fruits*

Ref.	Medidas Size Dimensions	Unidades Units Unités	Euros
C-93	19 x 12	12	38,00
C-95	24 x 20	12	57,00

**Liso pizarra, Ganchos**

Plane board, Hooks

*Tableau lisse, Crochets*

Ref.	Medidas Size Dimensions	Unidades Units Unités	Euros
C-94	19 x 12	12	38,00
C-96	24 x 20	12	57,00

**NÚMEROS RECAMIABLES | CHANGEABLE NUMBERS | CHIFFRES INTERCHANGEABLES****Núm. recambiable, arandela**

Num. rechargeable, washer

*Num. rechargeable, ronelle*

Ref.	Medidas Size Dimensions	Unidades Units Unités	Euros
C-79	11 x 9 cm	12	37,00

**Pergamino, núm. recambiable  
Con pincho acero inoxidable**Scroll, num. interchangeable  
With stainless steel pin*Parchemin, num. interchangeable  
Avec pique en acier inox.*

Ref.	Medidas Size Dimensions	Unidades Units Unités	Euros
C-87	15 x 11 cm	12	40,00

**Pergamino, núm. recambiable, arandela**

Scroll, num. interchangeable, washer

*Parchemin, num. interchangeable, rondelle*

Ref.	Medidas Size Dimensions	Unidades Units Unités	Euros
C-87-A	15 x 11 cm	12	40,00

**Huevos, núm. recambiable**

Eggs, num. interchangeable

*Oeufs, num. interchangeable*

Ref.	Medidas Size Dimensions	Unidades Units Unités	Euros
C-88	15 x 14 cm	6	39,00

**Pergamino, núm. recambiable**

Scroll, num. interchangeable

*Parchemin, num. interchangeable*

Ref.	Medidas Size Dimensions	Unidades Units Unités	Euros
C-89	20 x 15 cm	6	37,00





**Peana inox con pinza**

Stainless stand with pincer

Inox socle avec pince

Ref.	Altura Height Hauteur	Unidades Units Unités	Euros
C-205	10 cm	4	35,50

SOPORTES CARTELES INYECCIÓN | INJECTION TAGS STAND | SUPPORT AFFICHES INJECTION



**Plataforma con tubo**

Platform with tube

Plate-forme avec tube

Ref.	Altura Height Hauteur	Color Colour Couleur	Unidades Units Unités	Euros
C-1	20 cm	○	12	20,00
C-1-N	20 cm	●	12	23,50



**Pinza para plataforma C-1**

Clip platform C-1

Clip plate-forme C-1

Ref.	Color Colour Couleur	Unidades Units Unités	Euros
C-1-P		12	10,00
C-1PN	●	12	12,00



**Peana**

Stand

Socle

Ref.	Color Colour Couleur	Unidades Units Unités	Euros
C-4-B	○	12	16,00
C-4-M	●	12	16,00



**Pinza para cubetas**

Pincer trays

Pince bac

Ref.	Unidades Units Unités	Euros
C-9	12	17,00



**Peana base redonda**  
Peana base redonda 8,5cm con soporte.

Ref.	Unidades Units Unités	Euros
C-210	10	25,50



**Pinza plástica**

Plastic salad clip

*Pince en plastique*

Ref.	Largo Long Longueur	Unidades Units Unités	Euros
C-215-N	80 mm	10	24,50
C-215-B	80 mm	10	24,50



**Peana base redonda**  
Peana base redonda 8,5 cm con soporte  
12,5 cm.

Ref.	Unidades Units Unités	Euros
C-211	10	32,00



**Pinza abertura máxima**  
Pinza abertura máxima 3 cm con soporte.

Maximum aperture clamp  
Maximum opening with support clamp 3 cm.

*Pince d'ouverture maximum*  
*Ouverture maximale avec le support de serrage 3 cm.*

Ref.	Unidades Units Unités	Euros
C-212	10	33,00



**Pinza abertura máxima**  
Pinza abertura máxima 1 cm con soporte.

Maximum aperture clamp  
Maximum opening with support clamp 1 cm.

*Pince d'ouverture maximum*  
*Ouverture maximale avec le support de serrage 1 cm.*

Ref.	Unidades Units Unités	Euros
C-213	10	21,00



**Pinza abertura máxima**  
Pinza abertura máxima 1 cm soporte 15 cm.

Maximum aperture clamp  
Maximum aperture support gripper 1 cm 15 cm.

*Pince d'ouverture maximum*  
*Ouverture maximale support pince 1 cm à 15 cm.*

Ref.	Unidades Units Unités	Euros
C-214	10	29,00

**Material: Glaspar, Números recambiables**  
 Material: Glaspar, Numbers changeable  
 Matériel: Glaspar, Chiffres interchangeable



**Polleria Combinada**

Poultry store Combined

Volaille Combinée

Ref.	Medidas Size Dimensions	Euros
C-25	39 x 35	39,00



**Lista oficial porcino**

Pork official list

Officiel porcin

Ref.	Medidas Size Dimensions	Euros
C-26	54 x 48	42,00

**Lista oficial ternera**

Veal official list

Officiel veau

Ref.	Medidas Size Dimensions	Euros
C-27	57 x 35	42,00

**Lista oficial cordero**

Lamb official list

Officiel agneau

Ref.	Medidas Size Dimensions	Euros
C-28	57 x 35	42,00



**Cartel listas especiales Superior a 12 x 16, incluido números, fotos y textos.**

Special lists tag  
 Top a 12 x 16, including numbers photos and text.

Cartel listes spéciales  
 Affiche 12 x 16 y compris les numéros, les photos et les textes.

Ref.	Euros
C-57	CONSULTAR

Material: Glaspar, Números recambiables  
 Material: Glaspar, Numbers changeable  
 Matériel: Glaspar, Chiffres interchangeable



**Jamones**

Ham

Jambon

Ref.	Medidas Size Dimensions	Euros
C-30	40 x 30	29,50



**Paletas**

Shoulder

Épaule

Ref.	Medidas Size Dimensions	Euros
C-30-P	40 x 30	29,50



**Pollos**

Chicken

Poulet

Ref.	Medidas Size Dimensions	Euros
C-32	40 x 30	29,50



**Gallinas**

Hen

Poule

Ref.	Medidas Size Dimensions	Euros
C-33	40 x 30	29,50



**Conejos**

Rabbit

Lapin

Ref.	Medidas Size Dimensions	Euros
C-31	40 x 30	29,50

**CARTELES DESPIECE | CUT TAGS | AFFICHES DÉCOUPE**

Material: Glaspar  
 Material: Glaspar  
 Matériel: Glaspar



**Despiece porcino**

Pork quartering

Dépeçage porc

Ref.	Medidas Size Dimensions	Euros
C-62	60 x 50	22,50

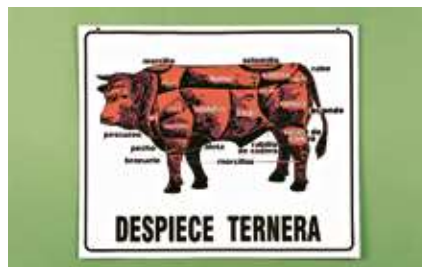

**Despiece ternera**

Veal quartering

Dépeçage veau

Ref.	Medidas Size Dimensions	Euros
C-63	60 x 50	22,50



**Despiece cordero**

Lamb quartering

Dépeçage agneau

Ref.	Medidas Size Dimensions	Euros
C-64	60 x 50	22,50



**Triángulo dos caras "Peligro suelo mojado". Material ABS amarillo. 62x30 cm**

Triangle two faces "Danger wet ground". Yellow ABS material. 62x30 cm

*Triangle deux faces "Danger sol humide". Matériau ABS jaune. 62x30 cm*

Ref.	Euros
C-500	18,00





**Guirnalda perejil**

Parsley

*Persil*

Ref.	Largo Long Longueur	Euros
X-2500	270 cm	24,00



**Hiedra**

Ivy

*Lierre*

Ref.	Largo Long Longueur	Euros
X-2503	270 cm	32,00



**Flor de viña**

Vine flowers

*Fleur de vigne*

Ref.	Largo Long Longueur	Euros
X-2504	270 cm	33,00



**Rosas rosas**

Pink roses

*Roses roses*

Ref.	Largo Long Longueur	Euros
X-2505	180 cm	22,00



**Novidad**

Christmas

*Noël*

Ref.	Largo Long Longueur	Euros
X-2514	180 cm	34,00



**Guirnalda tomates**

Tomatoes

*Tomates*

Ref.	Largo Long Longueur	Euros
X-2800	200 cm	45,00



**Guirnalda limones**

Lemons

*Citrons*

Ref.	Largo Long Longueur	Euros
X-2801	180 cm	39,00



**Guirnalda manzanas**

Apples

*Pommes*

Ref.	Largo Long Longueur	Euros
X-2804	200 cm	34,00



**Guirnalda viña verde**

Green vine

*Vigne vert*

Ref.	Largo Long Longueur	Euros
X-2509	180 cm	25,00

**Hoja lechuga**

Lettuce leaf

*Feuille Laitue*

Ref.	Unidades Units Unités	Euros
X-2530	12	27,00

**Hoja helecho**

Fern leaf

*Feuille fougère*

Ref.	Unidades Units Unités	Euros
X-2515	10	9,00

## SEPARADORES | SEPARATORS | SÉPARATEURS

**Separador Perejil base inox**

Separator Parsley stainless steel base 25 cm

*Séparateur Persil base acier inox. 24 cm*

Ref.	Largo Long Longueur	Unidades Units Unités	Euros
A-1	25 cm	1	15,00

**Separador Perejil**

Separator Parsley

*Séparateur Persil*

Ref.	Largo Long Longueur	Unidades Units Unités	Euros
X-0024	24 cm	12	75,00

**Separador rosa roja**

Separator red rose

*Séparateur roses rouges*

Ref.	Largo Long Longueur	Unidades Units Unités	Euros
X-0724	24 cm	12	78,00





**Separador Ciprés verde, base 9,5 x 75**

Separator Green cypress, base 9,5 x 75

*Séparateur Cyprés vert, base 9,5 x 75*

Ref.	Euros
X-0100	32,00



**Separador Verde-rojo, base 9,5 x 75**

Separator Green-red, base 9,5 x 75

*Séparateur Vert-rouge base 9,5 x 75*

Ref.	Euros
X-0101	32,00



**Separador Perejil, base 9,5 x 75**

Separator Parsley, base 9,5 x 75

*Séparateur Persil, base 9,5 x 75*

Ref.	Euros
X-0102	34,00



**Separador Blanco 15 x 75**

Separator White 15 x 75

*Séparateur Blanc 15 x 75*

Ref.	Euros
X-0200	25,00



**Separador Verde 15 x 75**

Separator Green 15 x 75

*Séparateur Vert 15 x 75*

Ref.	Euros
X-0201	26,00



**Separador Transparente 15 x 75**

Separator Transparent 15 x 75

*Séparateur Transparent 15 x 75*

Ref.	Euros
X-0202	27,00



**Separador Rojo 15 x 75**

Separator Red 15 x 75

*Séparateur Rouge 15 x 75*

Ref.	Euros
X-0203	26,00



**Separador Negro 15 x 75**

Separator Black 15 x 75

*Séparateur Noir 15 x 75*

Ref.	Euros
X-0204	26,00



**Separador Blanco con adorno verde 7 x 75**

Separator White with green decoration 7 x 75

*Séparateur Blanc avec ornement vert 7 x 75*

Ref.	Euros
X-0210	23,00





**Mejillones con limones**

Mussels and lemons

*Mouellets et citrons*

Ref.	Euros
X-2900	29,00

**Gaviota**

Seagull

*Gavotte*

Ref.	Euros
X-2903	34,00

**Conchas 4 unidades**

Shells 4 units

*Coquillages 4 unités*

Ref.	Euros
X-2906	19,50

**Bogavante**

Lobster

*Homar*

Ref.	Euros
X-2901	19,00

**Truchas**

Trouts

*Trites*

Ref.	Euros
X-2904	41,00

**Bolsa con hielo**

Ice bag

*Sachet avec glaçons*

Ref.	Euros
X-2907	24,00

**Cangrejo de mar**

Crab

*Crabe*

Ref.	Euros
X-2902	31,00

**Estrella de mar - 2 unid.**

Starfish - 2 units

*Étoile de mer - 2 unités*

Ref.	Euros
X-2905	17,00

**Red de pesca**

Fishing net

*Filet de pêche*

Ref.	Medidas Size Dimensions	Euros
X-2909	200 x 150 cm	24,00



**Separador PLEXI GLASS**

Divider

*Séparation*

Ref.	Medidas Size Dimensions	Euros
X-9005	600 x 200	52,00
X-6886	800 x 200	63,00



**Jamón**

Ham

*Jambon*

Ref.	Euros
X-2910	64,00



**CH12-18 - Barreño industrial sin tap**

CH12-18 - Industrial tub no lid

CH12-18 - Bassine industriel sans couvercle

Ref.	Medidas Size Dimensions	Capacidad Capacity Capacité	Euros
CH-12	35 x 19 cm	12 l	13,50
CH-18	39 x 21 cm	18 l	17,00

**Barreño industrial con tapa**

Industrial tub with lid

Bassine industriel avec couvercle

Ref.	Medidas Size Dimensions	Capacidad Capacity Capacité	Euros
CH-30	49 x 26 cm	30 l	35,00
CH-40	49 x 37 cm	40 l	41,00
CH-50	49 x 45 cm	50 l	43,00
CH-75	50 x 60 cm	75 l	63,00
CH-100	54 x 69 cm	100 l	82,00

**Cubo con medidor 30x29, asa inox., 13L.**

Bin with measure 30x29, stainless steel handle, 13L.

Seau avec mesureur 30x29, anse inox, 13L

Ref.	Medidas Size Dimensions	Capacidad Capacity Capacité	Euros
CH-10	30 x 29 cm	13 l	17,00

**CUBETA, BASE RODANTE | CONTAINER, ROLLING BASE | BAC, BASE ROULANTE**



**Cubeta azul pescadería**

Blue box fishmonger's

Basin bleu poissonnerie

Ref.	Medidas Size Dimensions	Euros
CC-14	60 x 40 x 12,5 cm	16,50



**Cubeta encajable con tapa integrada azul  
Medidas base 50,8 x 33,8**

Blue container stackable with lid  
Base measures 50,8 x 33,8

Bac bleu encastrable avec couvercle  
Dimensions de base 50,8 x 33,8

Ref.	Medidas Size Dimensions	Euros
CC-32	60 x 40 x 32 cm	34,50



**Base rodante para cubetas con 4 ruedas giratorias de poliamida.**

Rolling base with 4 nylon wheels with natural rubber

Base roulante avec 4 roues giratoires en nylon et caoutchouc naturel.

Ref.	Medidas Size Dimensions	Carga Máxima Maximum load Charge maximale	Euros
R-40	60 x 40 cm	250 KGS	114,00



### Cubeta encajables

Container stackable

Bac encastrable

Ref.	Medidas Size Dimensions	Capacidad Capacity Capacité	Euros
CH-1	26 x 26 x 16 cm	6 l	7,50
CH-2	30 x 30 x 18 cm	10 l	10,00
CH-3	34 x 34 x 20 cm	14 l	13,50
CH-4	30 x 30 x 12 cm	7.5 l	8,50
CH-6	25 x 18 x 23 cm	8 l	7,50
CH-7	32 x 29 x 40 cm	26 l	17,00



### Cubetas con asas apilable y encajable

Container with handles stackable

Bac empilable et encastrable

Ref.	Medidas Size Dimensions	Capacidad Capacity Capacité	Euros
CC-20	65 x 45 x 22,5 cm	20 l	37,50
CC-40	65 x 45 x 32 cm	40 l	45,50
CC-60	65 x 45 x 42,5 cm	60 l	60,00
CC-100	77 x 59,5 x 42,5 cm	100 l	74,00



### Cubeta apilables

Container stackable

Bac empilable

Ref.	Medidas Size Dimensions	Capacidad Capacity Capacité	Euros
CC-9	60 x 40 x 5,5 cm	9 l	14,50
CC-10	40 x 30 x 11,8 cm	11 l	12,50
CC-12	39,5 x 29,5 x 16 cm	12 l	18,00
CC-15	40 x 30 x 17,5 cm	16 l	14,50
CC-16	39,5 x 29,5 x 21,5 cm	15 l	20,00
CC-19	60 x 40 x 9 cm	19 l	15,50
CC-21	60 x 40 x 11,8 cm	21 l	20,00
CC-33	60 x 40 x 17	33 l	21,00

### Tapa

Lid

Couvercle

Ref.	Medidas Size Dimensions	Euros
CCT-39	39,5 x 29,5 cm	10,00
CCT-40	40 x 30 cm	7,00
CCT-60	60 x 40 cm	14,50



### Honda

Deep

Creux

Ref.	Medidas Size Dimensions	Euros
BX-4	33 x 23 x 2,5 cm	25,00
BX-5	40 x 30 x 2,5 cm	34,00
BX-6	51 x 35 x 2,5 cm	43,00
BX-9	36 x 27 x 2,5 cm	29,00



### Plana

Flat

Plat

Ref.	Medidas Size Dimensions	Euros
BXP-2	32 x 22 cm	25,00
BXP-3	39 x 29 cm	34,00
BXP-4	50 x 34,5 cm	43,00
BXP-5	35 x 26 cm	29,00

## BANDEJAS METACRILATO NEGRA | BLACK METHACRYLATE TRAYS | PLATEAUX MÉTHACRYLATE NOIRS



### Honda

Deep

Creux

Ref.	Medidas Size Dimensions	Euros
BZ-1	33 x 23 x 2,5 cm	19,00
BZ-2	36 x 27 x 2,5 cm	23,50
BZ-3	40 x 30 x 2,5 cm	25,50
BZ-4	51 x 35,5 x 2,5 cm	33,00
BZ-5	30,5 x 16 x 2,5 cm	17,00
BZ-6	46 x 16,5 x 2,5 cm	19,00
BZ-10	58 x 38,5 x 2,5 cm	51,50



### Plana

Flat

Plat

Ref.	Medidas Size Dimensions	Euros
BZP-1	32 x 22 cm	19,00
BZP-2	35 x 26 cm	23,50
BZP-3	39 x 29 cm	25,50
BZP-4	50 x 34,5 cm	33,00





**Honda**

Deep

*Creux*

Ref.	Medidas Size Dimensions	Euros
BB-1	30,5 x 16 x 2,5 cm	14,00
BB-2	16,5 x 46 x 2,5 cm	16,00
BB-3	20 x 27 x 2,5 cm	15,00
BB-4	23 x 33 x 2,5 cm	17,00
BB-5	30 x 40 x 2,5 cm	13,50
BB-6	51 x 35,5 x 2,5 cm	29,50
BB-9	36 x 27 x 2,5 cm	21,00
BB-10	58 x 38,5 x 2,5 cm	48,50

**Plana**

Flat

*Plat*

Ref.	Medidas Size Dimensions	Euros
BBP-1	26 x 19 cm	15,00
BBP-2	22 x 32 cm	17,00
BBP-3	29 x 39 cm	23,50
BBP-4	50 x 34,5 cm	29,50
BBP-5	35 x 26 cm	21,00

**Redonda**

Round

*Rond*

Ref.	Diámetro Diameter Diamètre	Euros
BB-8	Ø 24,5 cm	15,00

**Cubetita**

Container

*Petit bac*

Ref.	Medidas Size Dimensions	Euros
BB-7	35,5 x 23,5 x 3,5 cm	18,00



### Bandejas acero-inox

Stainless Steel trays

Plateaux acier-inox

Ref.	Tipo Type	Medidas Size Dimensions	Euros
GI-2/1-20	2/1	65 x 53 x 2 cm	68,00
GI-1/1-20	1/1	53 x 32,5 x 2 cm	29,00
GI-2/4-20	2/4	53 x 16,5 x 2 cm	21,00
GI-2/3-20	2/3	35,5 x 32,5 x 2 cm	22,00
GI-1/2-20	1/2	32,5 x 26,5 x 2 cm	16,00
GI-1/3-20	1/3	32,5 x 17,5 x 2 cm	13,50
GI-1/4-20	1/4	26,4 x 16,2 x 2 cm	12,00



### Bandeja autoservicio 3 compartimentos acero inox

Self-service tray  
3 compartments stainless steel

Plateau self-service  
3 compartiments acier inox

Ref.	Diámetro Diameter Diamètre	Euros
BA-3	Ø 28 cm	27,50



### Bandeja autoservicio

Self-service tray

Plateau self-service

Ref.	Medidas Size Dimensions	Euros
BA-5	34,5 x 34,5 x 3,5 cm	35,50



### Bandejas Pasteleras Acero Inox. / Aluminio

Stainless steel / aluminum pastry trays

Ref.	Medidas Size Dimensions	Euros
BAC-1	60 x 40 x 1 cm	55,00
BAL-1	60 x 40 x 1 cm	37,00



### Cubetas por inyección-s

S injection trays

Bacs par injection-s

Ref.	Medidas Size Dimensions	Capacidad Capacity Capacité	Euros
BC-0	30 x 20 x 6 cm	2 l	4,50
BC-1	34 x 23 x 7 cm	3 l	5,00
BC-2	43 x 28 x 7,5 cm	5 l	7,50
BC-3	48 x 33 x 7,8 cm	8 l	9,50
BC-4	54 x 38 x 8,3 cm	10 l	12,00
BC-5	60 x 40 x 9 cm	15 l	13,00

\* Otros colores consultar

\* Other colors consult

\* Autres couleurs consulter

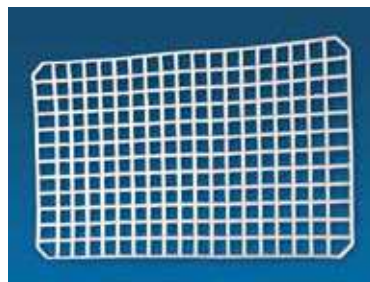

### Rejillas blancas para cubetas

White grids for buckets

Grilles blanches pour seaux

Ref.	Medidas Size Dimensions	Euros
BCR-5	39,5 x 24,7 cm	12,00

Ref.	Modelo rejillas Grid model Modèle de grille	Euros
BCR-0	Para BC-0	3,30
BCR-1	Para BC-1	3,50
BCR-2	Para BC-2	3,80
BCR-3	Para BC-3	4,00
BCR-4	Para BC-4	5,00



### Tapas transparentes

Transparent lids

Couvercles transparents

Ref.	Modelo tapas Caps model Modèle de casquettes	Euros
BCT-0	Para BC-0	3,50
BCT-1	Para BC-1	3,80
BCT-2	Para BC-2	4,10
BCT-3	Para BC-3	6,00



### Rejillas para cubetas negras

Black tray grille

Grille pour bac noir

Ref.	Medidas Size Dimensions	Euros
BCR-5-N	39,5 x 24,7 cm	12,00



### Cubetas por inyección-s negras

Injection-s containers black

Bacs par injection-s noir

Ref.	Medidas Size Dimensions	Capacidad Capacity Capacité	Euros
BC-0-N	30 x 20 x 6 cm	2 l	4,50
BC-1-N	34 x 23 x 7 cm	3 l	5,00
BC-2-N	43 x 28 x 7,5 cm	5 l	7,50
BC-3-N	48 x 33 x 7,8 cm	8 l	9,50
BC-4-N	54 x 38 x 8,3 cm	10 l	12,00



### Bandejas por inyección alta presión

High pressure injection trays

Plateaux par injection haute pression

Ref.	Medidas Size Dimensions	Euros
BI-11	29 x 20 x 2 cm	8,00
BI-12	33 x 22,5 x 2 cm	9,00
BI-13	40 x 29 x 2 cm	11,00
BI-14	60 x 40 x 2 cm	20,00



### Bandejas ABS para carros R-10/R-20

ABS tray

Plateaux à pâtisserie en acier inoxydable / aluminium

Ref.	Medidas Size Dimensions	Color Couleur Couleur	Euros
BI-15-B	58,5 x 41 x 2,5 cm	○	19,00
BI-15-N	58,5 x 41 x 2,5 cm	●	20,00
BI-15-R	58,5 x 41 x 2,5 cm	●	20,00

### BANDEJAS POR INYECCIÓN BAJA PRESIÓN | LOW PRESSURE INJECTION TRAYS | PLATEAUX PAR INJECTION BASSE PRESSION



### Bandejas por inyección baja presión

Low pressure injection trays

Plateaux par injection basse pression

Ref.	Medidas Size Dimensions	Euros
BI-21	29 x 20 x 2 cm	4,50
BI-22	33 x 22,5 x 2 cm	5,00
BI-23	40 x 29 x 2 cm	7,50



### Bandejas por inyección presión negra

Low pressure injection trays black

Plateaux par injection basse pression noir

Ref.	Medidas Size Dimensions	Euros
BI-21-N	29 x 20 x 2 cm	4,50
BI-22-N	33 x 22,5 x 2 cm	5,00
BI-23-N	40 x 29 x 2 cm	7,50



**Cubetas gastronorm policarbonato. Temperatura - 40° + 110°**

Gastronorm polycarbonate containers. Temperature - 40° + 110°

Bacs gastronorm polycarbonate. Température - 40° + 110°



Ref.	Tipo Type	Medidas Size Dimensions		Euros
GP-2/1-200	2/1	65 x 53 x 20 cm		67,00
GP-1/1-65	1/1	53 x 32,5 x 6,5 cm		18,50
GP-1/1-100	1/1	53 x 32,5 x 10 cm		24,00
GP-1/1-150	1/1	53 x 32,5 x 15 cm		27,00
GP-1/1-200	1/1	53 x 32,5 x 20 cm		36,00
GP-1/2-65	1/2	32,5 x 26,5 x 6,5 cm		10,00
GP-1/2-100	1/2	32,5 x 26,5 x 10 cm		12,00
GP-1/2-150	1/2	32,5 x 26,5 x 15 cm		15,00
GP-1/2-200	1/2	32,5 x 26,5 x 20 cm		17,50
GP-1/3-65	1/3	32,5 x 17,5 x 6,5 cm		8,00
GP-1/3-100	1/3	32,5 x 17,5 x 10 cm		9,50
GP-1/3-150	1/3	32,5 x 17,5 x 15 cm		12,00
GP-1/3-200	1/3	32,5 x 17,5 x 20 cm		14,50
GP-1/4-65	1/4	26,4 x 16,2 x 6,5 cm		6,00
GP-1/4-100	1/4	26,4 x 16,2 x 10 cm		7,50
GP-1/4-150	1/4	26,4 x 16,2 x 15 cm		9,00
GP-1/4-200	1/4	26,4 x 16,2 x 20 cm		11,50
GP-1/6-65	1/6	17,6 x 16,2 x 6,5 cm		4,50
GP-1/6-100	1/6	17,6 x 16,2 x 10 cm		5,50
GP-1/6-150	1/6	17,6 x 16,2 x 15 cm		7,50
GP-1/6-200	1/6	17,6 x 16,2 x 20 cm		8,50
GP-1/9-65	1/9	17,6 x 10,8 x 6,5 cm		3,50
GP-1/9-100	1/9	17,6 x 10,8 x 10 cm		4,00

**Tapas policarbonato**

Polycarbonate lids

Couvercles polycarbonate

Ref.	Tipo Type	Medidas Size Dimensions	Euros
GPT 2/1	2/1	65 x 53 cm	39,00
GPT 1/1	1/1	53 x 32,5 cm	15,00
GPT 1/2	1/2	32,5 x 26,5 cm	8,00
GPT 1/3	1/3	32,5 x 17,5 cm	5,50
GPT 1/4	1/4	26,4 x 16,2 cm	4,50
GPT 1/6	1/6	17,6 x 16,2 cm	3,50
GPT 1/9	1/9	17,6 x 10,8 cm	3,00

**Doble fondo perforado policarbonato**

Polycarbonate perforated double base

Double fond perforé polycarbonate

Ref.	Tipo Type	Medidas Size Dimensions	Euros
GPFP-2/1	2/1	56,5 x 44,5 cm	22,00
GPFP-1/1	1/1	46,5 x 26,5 cm	9,00
GPFP-1/2	1/2	26,5 x 20,5 cm	5,00

## Cubetas gastronorm acero inoxidable. AISI 304 18/10

Stainless steel gastronorm containers. AISI 304 18/10

Bacs gastronorm acier inox. AISI 304 18/10



Ref.	Tipo Type Type	Medidas Size Dimensions		Euros
GI-2/1-20	2/1	65 x 53 x 2 cm		68,00
GI-2/1-40	2/1	65 x 53 x 4 cm		71,00
GI-2/1-65	2/1	65 x 53 x 6,5 cm		83,00
GI-2/1-100	2/1	65 x 53 x 10 cm		98,00
GI-2/1-150	2/1	65 x 53 x 15 cm		135,00
GI-2/1-200	2/1	65 x 53 x 20 cm		156,00
GI-1/1-20	1/1	53 x 32,5 x 2 cm		29,00
GI-1/1-40	1/1	53 x 32,5 x 4 cm		34,00
GI-1/1-65	1/1	53 x 32,5 x 6,5 cm		38,00
GI-1/1-100	1/1	53 x 32,5 x 10 cm		51,25
GI-1/1-150	1/1	53 x 32,5 x 15 cm		69,60
GI-1/1-200	1/1	53 x 32,5 x 20 cm		82,00
GI-2/3-20	2/3	35,5 x 32,5 x 2 cm		22,00
GI-2/3-40	2/3	35,5 x 32,5 x 4 cm		24,50
GI-2/3-65	2/3	35,5 x 32,5 x 6,5 cm		27,00
GI-2/3-100	2/3	35,5 x 32,5 x 10 cm		35,00
GI-2/3-150	2/3	35,5 x 32,5 x 15 cm		56,50
GI-2/3-200	2/3	35,5 x 32,5 x 20 cm		68,00
GI-1/2-20	1/2	32,5 x 26,5 x 2 cm		16,00
GI-1/2-40	1/2	32,5 x 26,5 x 4 cm		19,50
GI-1/2-65	1/2	32,5 x 26,5 x 6,5 cm		22,00
GI-1/2-100	1/2	32,5 x 26,5 x 10 cm		27,00
GI-1/2-150	1/2	32,5 x 26,5 x 15 cm		41,00
GI-1/2-200	1/2	32,5 x 26,5 x 20 cm		53,00
GI-1/3-20	1/3	32,5 x 17,5 x 2 cm		13,50
GI-1/3-40	1/3	32,5 x 17,5 x 4 cm		15,50
GI-1/3-65	1/3	32,5 x 17,5 x 6,5 cm		18,50
GI-1/3-100	1/3	32,5 x 17,5 x 10 cm		22,50
GI-1/3-150	1/3	32,5 x 17,5 x 15 cm		32,50
GI-1/3-200	1/3	32,5 x 17,5 x 20 cm		44,00
GI-1/4-20	1/4	26,4 x 16,2 x 2 cm		12,00
GI-1/4-40	1/4	26,4 x 16,2 x 4 cm		15,00
GI-1/4-65	1/4	26,4 x 16,2 x 6,5 cm		16,50
GI-1/4-100	1/4	26,4 x 16,2 x 10 cm		20,00
GI-1/4-150	1/4	26,4 x 16,2 x 15 cm		28,00
GI-1/4-200	1/4	26,4 x 16,2 x 20 cm		35,50



Ref.	Tipo Type	Medidas Size Dimensions	Euros
GI-1/6-65	1/6	17,6 x 16,2 x 6,5 cm	13,50
GI-1/6-100	1/6	17,6 x 16,2 x 10 cm	16,50
GI-1/6-150	1/6	17,6 x 16,2 x 15 cm	23,50
GI-1/6-200	1/6	17,6 x 16,2 x 20 cm	37,00
GI-1/9-65	1/9	17,6 x 10,8 x 6,5 cm	12,50
GI-1/9-100	1/9	17,6 x 10,8 x 10 cm	17,50

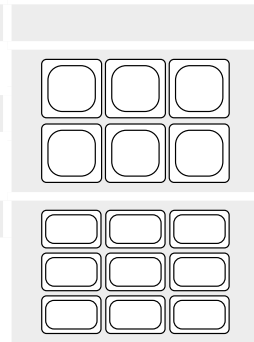

### Cubetas gastronorm perforadas acero inoxidable

Stainless steel gastronorm perforated containers

Bacs gastronorm perforées acier inox



Ref.	Tipo Type	Medidas Size Dimensions	Euros
GIP-2/1-20	2/1	65 x 53 x 2 cm	78,00
GIP-2/1-40	2/1	65 x 53 x 4 cm	81,00
GIP-2/1-65	2/1	65 x 53 x 6,5 cm	90,00
GIP-1/1-20	1/1	53 x 32,5 x 2 cm	32,00
GIP-1/1-40	1/1	53 x 32,5 x 4 cm	36,50
GIP-1/1-65	1/1	53 x 32,5 x 6,5 cm	40,50
GIP-1/1-100	1/1	53 x 32,5 x 10 cm	53,50
GIP-1/1-150	1/1	53 x 32,5 x 15 cm	81,50
GIP-1/1-200	1/1	53 x 32,5 x 20 cm	97,00
GIP-1/2-65	1/2	32,5 x 26,5 x 6,5 cm	23,00
GIP-1/2-100	1/2	32,5 x 26,5 x 10 cm	30,00
GIP-1/2-150	1/2	32,5 x 26,5 x 15 cm	48,00
GIP-1/2-200	1/2	32,5 x 26,5 x 20 cm	61,00

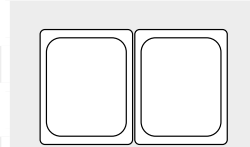
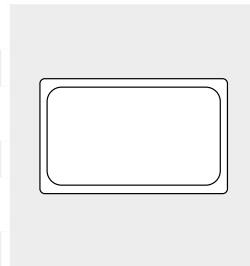
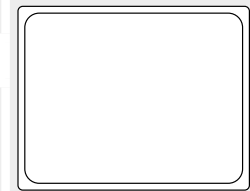

### Tapas de cubierta gastronorm acero inox.

Lids for stainless steel gastronorm container

Couvercles de bac gastronorm acier inox.

Ref.	Tipo Type	Medidas Size Dimensions	Euros
GIT-1/1	1/1	53 x 32,5 cm	30,00
GIT-2/3	2/3	35,5 x 32,5 cm	20,00
GIT-1/2	1/2	32,5 x 26,5 cm	16,50
GIT-1/3	1/3	32,5 x 17,5 cm	12,00
GIT-1/4	1/4	26,4 x 16,2 cm	10,50
GIT-1/6	1/6	17,6 x 16,2 cm	8,50
GIT-1/9	1/9	17,6 x 10,8 cm	7,50

### Tapas acero inoxidable hermética

Stainless steel tight lids

Couvercles acier inoxydable hermétique

Ref.	Tipo Type	Medidas Size Dimensions	Euros
GITH-1/1	1/1	53 x 32,5 cm	73,00
GITH-2/3	2/3	35,5 x 32,5 cm	51,00
GITH-1/2	1/2	32,5 x 26,5 cm	47,50
GITH-1/3	1/3	32,5 x 17,5 cm	36,50
GITH-1/4	1/4	26,4 x 16,2 cm	29,50
GITH-1/6	1/6	17,6 x 16,2 cm	27,00

**0 2 CUBETAS GASTRONORM ACERO INDOXIDABLE | STAINLESS STEEL GASTRONORM CONTAINERS | BACS GASTRONORM ACIER INOX**

**Doble fondo perforado acero inoxidable**

Stainless steel double base perforated

Double fond perforé acier inox

Ref.	Tipo Type Type	Medidas Size Dimensions	Euros
GIFP-2/1	2/1	59 x 47 cm	61,00
GIFP-1/1	1/1	47 x 27 cm	30,50
GIFP-2/3	2/3	29,5 x 26,5 cm	21,00
GIFP-1/2	1/2	26,5 x 20,5 cm	18,50

**Separadores acero inoxidable**

Stainless steel separators

Séparateurs acier inoxydable

Ref.	Tipo Type Type	Medidas Size Dimensions	Euros
GIS-530	1/1	53 x 2 cm	10,00
GIS-325	1/2	32,5 x 2 cm	7,00

**CUBETAS GASTRONORM PLEXILINE | PLEXILINE GASTRONORM CONTAINERS | BACS GASTRONORM PLEXILINE**

**Metacrilato acrílico. Apto lavavajillas. No apto para horno-microondas**

Acrylic methacrylate. Dishwasher safe. Not suitable for oven-microwave

Méthacrylate acrylique. Lave-vaisselle. Ne convient pas au four-micro-ondes

**System gastronorm, negro. Temperatura - 20° + 80°**

System gastronorm, black. Temperature - 20° + 80°

System gastronorm, noir. Température - 20° + 80°



Ref.	Tipo Type Type	Medidas Size Dimensions	Euros
BP-GN-1/1-17-N	1/1	53 x 32,5 x 1,7 cm	56,50
BP-GN 1/1-50-N	1/1	53 x 32,5 x 5 cm	64,00
BP-GN-1/2-17-N	1/2	32,5 x 26,5 x 1,7 cm	23,00
BP-GN 1/2-50-N	1/2	32,5 x 26,5 x 5 cm	32,50
BP-GN 1/3-17-N	1/3	32,5 x 17,6 x 1,7 cm	17,50
BP-GN 1/3-50-N	1/3	32,5 x 17,6 x 5 cm	24,00
BP-GN 1/4-17-N	1/4	26,5 x 16,2 x 1,7 cm	15,00
BP-GN 1/4-50-N	1/4	26,5 x 16,2 x 5 cm	20,00
BP-GN 1/5-17-N	1/5	26,5 x 20 x 1,7 cm	16,00
BP-GN 1/5-50-N	1/5	26,5 x 20 x 5 cm	20,00
BP-GN 1/6-50-N	1/6	17,6 x 16,2 x 5 cm	17,50
BP-GN 1/9-50-N	1/9	17,6 x 10,8 x 5 cm	15,00
BP-GN 2/4-17-N	2/4	53 x 16,2 x 1,7 cm	30,00
BP-GN 2/5-17-N	2/5	53 x 20 x 1,7 cm	32,50
BP-GN 3/4-17-N	3/4	48,7 x 26,5 x 1,7 cm	34,50
BP-GN 3/4-50-N	3/4	48,7 x 26,5 x 5 cm	42,00
BP-GN 5/4-40-N	5/4	81 x 26,5 x 4 cm	77,00



**Tapas transparente**

Transparent lid

Couvercle transparent

Ref.	Tipo Type Type	Medidas Size Dimensions	Euros
BPT-1/1-T	1/1	53 x 32,5 cm	44,50
BPT-1/2-T	1/2	32,5 x 26,5 cm	28,50
BPT-1/3-T	1/3	32,5 x 17,6 cm	27,50
BPT-1/4-T	1/4	26,5 x 16,2 cm	20,50
BPT-1/5-T	1/5	26,5 x 20 cm	27,00
BPT-2/5-T	2/5	53 x 20 cm	36,00
BPT-3/4-T	3/4	48,7 x 26,5 cm	40,00



**Rejillas negro**

Black grid

Grille noir

Ref.	Tipo Type Type	Medidas Size Dimensions	Euros
BPR-1/1-N	1/1	53 x 32,5 cm	59,50
BPR-1/2-N	1/2	32,5 x 26,5 cm	30,00
BPR-1/3-N	1/3	32,5 x 17,6 x 8 cm	20,50
BPR-1/4-N	1/4	26,5 x 16,2 cm	19,50
BPR-1/5-N	1/5	26,5 x 20 cm	23,50



**Triángulo**

Triangle

Triangle

Ref.	Medidas Size Dimensions	Altura Height Hauteur	Euros
BPTR-27-20-N	27 x 27 x 37 cm	2 cm	20,50
BPTR-40-20-N	40 x 40 x 56,5 cm	2 cm	32,50
BPTR-40-50-N	40 x 40 x 56,5 cm	5 cm	37,50





**9 Bandejas + escalera**  
 9 trays + step  
 9 plateaux + escalier  
**Temperatura - 20° + 80°**  
 Temperature - 20° + 80°  
 Température - 20° + 80°



x1



x2

**Escalera anfiteatro**

Step amphitheater

Escalier amphithéâtre

Ref.	Medidas Size Dimensions	Euros
BPA-ANFI	80 x 80 x 6,5 cm	349,00

**1/4 luna 90° negro**

1/4 moon 90° black

1/4 lune 90° noir

Ref.	Medidas Size Dimensions	Euros
BPA-90-50-N	26,5 x 26,5 x 5 cm	35,00

**Esquina 45° negro**

Corner 45° black

Coin 45° noir

Ref.	Tipo Type Type	Euros
BPA-45-50-N	39/22 x 26,5 x 5,0 cm	44,00



x4



x1



x1

**Esquina 22,5° negro**

Corner 22,5° black

Coin 22,5° noir

Ref.	Tipo Type Type	Euros
BPA-22G-50-N	30/21 x 26,0 x 5,0 cm	32,00

**Triángulo izquierdo negro**

Left triangle black

Triangle gauche noir

Ref.	Tipo Type Type	Euros
BPA-TI-50-N	53 x 30 x 5,0 cm	40,00

**Triángulo derecho negro**

Right triangle black

triangle droite noir

Ref.	Tipo Type Type	Euros
BPA-TD-50-N	53 x 30 x 5,0 cm	40,00

**13 Bandejas + escalera**

13 trays + step

13 plateaux + escalier

**Temperatura - 20° + 80°**

Temperature - 20° + 80°

Température - 20° + 80°



**Escalera anfiteatro**

Step amphitheater

Escalier amphithéâtre

Ref.	Medidas Size Dimensions	Euros
BPA-ANFI	80 x 80 x 6,5 cm	349,00



x1

**1/4 luna 90° negro**

1/4 moon 90° black

1/4 lune 90° noir

Ref.	Medidas Size Dimensions	Euros
BPA-90-50-N	26,5 x 26,5 x 5 cm	35,00



x4

**Esquina 22,5° negro**

Corner 22,5° black

Coin 22,5° noir

Ref.	Tipo Type Type	Euros
BPA-22P-50-N	20/11 x 26,5 x 5,0 cm	23,00



x6

**Esquina 15° negro**

Corner 15° black

Coin 15° noir

Ref.	Tipo Type Type	Euros
BPA-15-50-N	20/14 x 26,5 x 5,0 cm	21,00



x1

**Triángulo izquierdo negro**

Left triangle black

Triangle gauche noir

Ref.	Tipo Type Type	Euros
BPA-TI-50-N	53 x 30 x 5,0 cm	40,00



x1

**Triángulo derecho negro**

Right triangle black

triangle droite noir

Ref.	Tipo Type Type	Euros
BPA-TD-50-N	53 x 30 x 5,0 cm	40,00



**Oval 420 x 270 mm H30**

Oval 420 x 270 mm H30

Oval 420 x 270 mm H30

Ref.	Medidas Size Dimensions	Euros
BP-10063-N	42 x 27 x 3 cm	44,50



**Octo 265 x 200 mm H50 GN1/5**

Octo 265 x 200 mm H50 GN1/5

Octo 265 x 200 mm H50 GN1/5

Ref.	Medidas Size Dimensions	Euros
BP-6960-N	26,5 x 20 x 5 cm	25,00



**Octo 265 x 325 mm H45 GN1/2**

Octo 265 x 325 mm H45 GN1/2

Octo 265 x 325 mm H45 GN1/2

Ref.	Medidas Size Dimensions	Euros
BP-5355-N	26,5 x 32,5 x 4,5 cm	37,50



**Oval 265 x 200 mm H 65 mm GN1/5**

Oval 265 x 200 mm H 65 mm GN1/5

Oval 265 x 200 mm H 65 mm GN1/5

Ref.	Medidas Size Dimensions	Euros
BP-6665-N	26,5 x 20 x 6,5 cm	26,50



**Oval 265 x 325 mm H 65 mm GN1/2**

Oval 265 x 325 mm H 65 mm GN1/2

Oval 265 x 325 mm H 65 mm GN1/2

Ref.	Medidas Size Dimensions	Euros
BP-6661-N	26,5 x 32,5 x 6,5 cm	35,00



**Redonda Ø 300 mm H 65 mm**

Round Ø 300 mm H 65 mm

Round Ø 300 mm H 65 mm

Ref.	Altura Height Hauteur	Diámetro Diameter Diamètre	Euros
BP-6670-N	6,5 cm	Ø 30 cm	39,50



**Redonda/Exa 175 mm H 80 mm 1,5l**

Round/Hexa 175 mm H 80 mm 1,5l

Round/Hexa 175 mm H 80 mm 1,5l

Ref.	Altura Height Hauteur	Diámetro Diameter Diamètre	Euros
BP-4013-N	8 cm	Ø 17,5 cm	26,50



**Redonda/Exa 215 mm H 80 mm 2,5l**

Round/Hexa 215 mm H 80 mm 2,5l

Round/Hexa 215 mm H 80 mm 2,5l

Ref.	Altura Height Hauteur	Diámetro Diameter Diamètre	Euros
BP-6675-N	8 cm	Ø 21,5 cm	33,00



**Tapa Plexiline redonda/hexa transparente**

Plexiline lid round/hexa transparent

Couvercle plexiline roud/hexa transparent

Ref.	Diámetro Diameter Diamètre	Para For Pour	Euros
BPT-4015	Ø 175	Ref. BP-4013-N	10,00
BPT-6680	Ø 215	Ref. BP-6675-N	13,50





**Base 8 x 1,5l Redonda/Exa. HIPS 800x400 mm H 80 mm. Para ref. BP-4013-N.**

Holder 8 x 1,5l Round/Hex. HIPS 800x400 mm H 80 mm. For ref. BP-4013-N.

Holder 8 x 1,5l Rond/Hex. HIPS 800x400 mm H 80 mm. Pour ref. BP-4013-N.

Ref.	Medidas Size Dimensions	Euros
<b>BPB-25140</b>	80 x 40 x 8 cm	<b>191,00</b>



**Cubeta concha 270x250 mm H 70 mm**

Shelf Shell 270x250 mm H 70 mm

Seau Coquille 270x250 mm H 70 mm

Ref.	Medidas Size Dimensions	Euros
<b>BP-5356-N</b>	27 x 25 x 7 cm	<b>38,50</b>



**Cubeta Huevo 300x210 mm H 75 mm**

Egg shelf 300x210 mm H 75 mm

Seau Oeuf 300x210 mm H 75 mm

Ref.	Medidas Size Dimensions	Euros
<b>BP-5921-N</b>	30 x 21 x 7,5 cm	<b>44,50</b>



**Yin Yang 300 mm H 65 mm**

Yin Yang 300 mm H 65 mm

Yin Yang 300 mm H 65 mm

Ref.	Altura Height Hauteur	Diámetro Diameter Diamètre	Euros
<b>BP-5869-N</b>	6,5 cm	Ø 30 cm	<b>27,50 unidad</b>



**ACCESORIOS | ACCESSORIES | ACCESOIRES**



**Escalón 3 niveles 500x800 mm H 80 mm**

Step 3 levels 500x800 mm H 80 mm

Étape 3 niveaux 500x800 mm H 80 mm

Ref.	Medidas Size Dimensions	Euros
<b>BPB-9232-N</b>	500 x 800 x 80 mm	<b>196,00</b>



**Escalón 3 niveles 250x800 mm H 80 mm**

Step 3 levels 250x800 mm H 80 mm

Étape 3 niveaux 250x800 mm H 80 mm

Ref.	Medidas Size Dimensions	Euros
<b>BPB-10569-N</b>	250 x 800 x 80 mm	<b>148,00</b>



**Escalón 1 nivel 624x280 mm H 75 mm**

Step 1 level 624x280 mm H 75 mm

Étape 1 niveau 624x280 mm H 75 mm

Ref.	Medidas Size Dimensions	Euros
<b>BPB-17068-N</b>	624 x 280 x 75 mm	<b>95,00</b>



**Escalón 1 nivel 624x280 mm H 35 mm**

Step 1 level 624x280 mm H 35 mm

Étape 1 niveau 624x280 mm H 35 mm

Ref.	Medidas Size Dimensions	Euros
<b>BPB-17069-N</b>	624 x 280 x 35 mm	<b>82,00</b>



**Escalón 1 nivel 312x280 mm H 75 mm**

Step 1 level 312x280 mm H 75 mm

Étape 1 niveau 312x280 mm H 75 mm

Ref.	Medidas Size Dimensions	Euros
<b>BPB-17071-N</b>	312 x 280 x 75 mm	<b>48,00</b>



**Escalón 1 nivel 312x280 mm H 35 mm**

Step 1 level 312x280 mm H 35 mm

Étape 1 niveau 312x280 mm H 35 mm

Ref.	Medidas Size Dimensions	Euros
<b>BPB-17070-N</b>	312 x 280 x 35 mm	<b>41,50</b>



**Pala de picar**

Spoon minced

Pelle à hacher

Ref.	Largo Long Longueur	Euros
<b>BP-1946-N</b>	260 mm	<b>11,00</b>



**Cuchara**

Spoon

Cuillère

Ref.	Largo Long Longueur	Euros
<b>BP-6901-N</b>	240 mm	<b>4,50</b>



**Cuchara perforadora**

Perforated spoon

Cuillère perforée

Ref.	Largo Long Longueur	Euros
<b>BP-14330-N</b>	250 mm	<b>5,50</b>



**Expositor de sandwich**

Sandwich display

Porte Sandwich

Ref.	Medidas Size Dimensions	Euros
<b>BP-9327-N</b>	520 x 135 x 50 mm	<b>38,50</b>



**Pinza plástica**

Plastic salad clip

Pince en plastique

Ref.	Largo Long Longueur	Unidades Units Unités	Euros
<b>C-215-N</b>	80 mm	10	<b>24,50</b>
<b>C-215-B</b>	80 mm	10	<b>24,50</b>



**Base giratoria 80 cm**

Rotating base 80 cm

Base tournante 80 cm

Ref.	Altura Height Hauteur	Diámetro Diameter Diamètre	Euros
BPC-24544-N	5 mm	Ø 800 mm	424,00



x4

**Triángulo**

Triangle

Triangle

Ref.	Medidas Size Dimensions	Euros
BPC-22861-N	325 x 158 x 60 mm	24,00



x8

**GN 1/5 265x265 mm**

GN 1/5 265x265 mm

GN 1/5 265x265 mm

Ref.	Medidas Size Dimensions	Euros
BPC-22860-N	265 x 265 x 80 mm	32,00



x1

**Ensaladera Redonda 2,5l**

Round salad dish 2,5l

Assiette à salade ronde 2,5l

Ref.	Altura Height Hauteur	Diámetro Diameter Diamètre	Euros
BPC-22866-N	80 mm	Ø 225 mm	33,00





0

3

**Picadoras, Picadora refrigerada, Cuchillas  
Placas, Empujadores picadoras, Cortadoras,  
Ralladora, Exprimidor, Cortadora multifunción,  
Enternecedor de carne, Cutters, Molino,  
Afiladoras, Cintas de sierra.**

---

Mincers, Refrigerated mincers, Blades plates,  
Mincer pusher, Slicer, Grater, Juicer, Multi-  
purpose slicer, Meat tenderizer, Cutters, Mill,  
Sharpener, Band saws.

---

*Hachoirs, Hachoirs refrigerés, Lames plaques,  
Poussoir hachoirs, Trancheuse, Râpes, Presse,  
Decoupoir multifonction, Attendrissant, Cutter,  
Moulin, Aiguiseur, Scies à ruban.*

**63 - 86**

**Picadora de carne**

**Boca 12. Cuerpo: acero inoxidable. Grupo picador: acero inoxidable. Cuchilla autoafilante. Interruptor: invertidor de marcha. Potencia 1 HP. Motor: trifásico 220/380 V. Producción: 120 kg/h**

**Meat mincer**

Outlet: 12. Body: stainless steel. Mincer set: stainless steel. Self-sharpening blade. Reverse switch. Power 1 HP. Engine : three phase 220 / 380. Production 120 kg/h.

**Hachoir à viande**

Goulot: 12. Corps: acier inoxydable. Groupe hachoir: acier inoxydable. Couteau: auto aiguiser. Interrupteur: inverseur. Puissance: 1 HP. Moteur : triphase 220/380. Production: 120 kg.

**Picadora de carne**

**Boca 12. Cuerpo: acero inoxidable. Grupo picador: acero inoxidable. Cuchilla autoafilante. Interruptor: invertidor de marcha. Potencia: 1 HP. Motor: monofásico 220 V. Producción: 120 kg/h**

**Meat mincer**

Outlet: 12. Body: stainless steel. Mincer set: stainless steel. Self-sharpening blade. Reverse switch. Power 1 HP. Engine: one phase 220. Production 120 kg/h.

Goulot: 12. Corps: acier inoxydable. Groupe hachoir: acier inoxydable. Couteau: auto aiguiser. Interrupteur: inverseur. Puissance: 1 HP. Moteur: monophasé 220. Production 120 kg.

Ref.	Peso Weight Poids	Euros
MP-12MEC-T	23 kg	1184,00

Ref.	Peso Weight Poids	Euros
MP-12MEC-M	23 kg	1216,00



**Despiece / Quartering / Dépeçage**

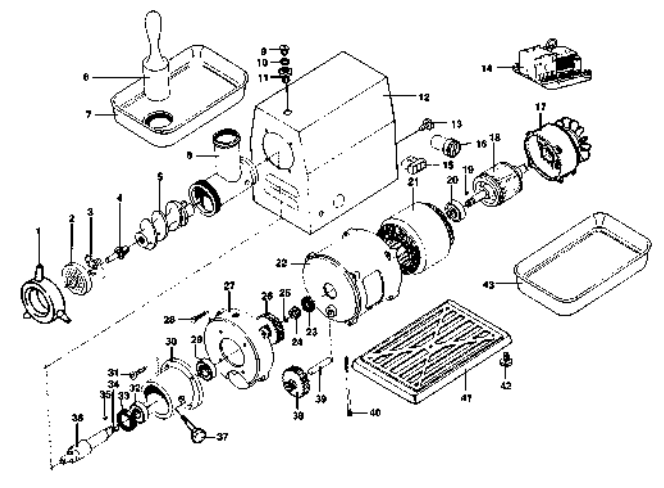

**Medidas / Size / Dimensions**

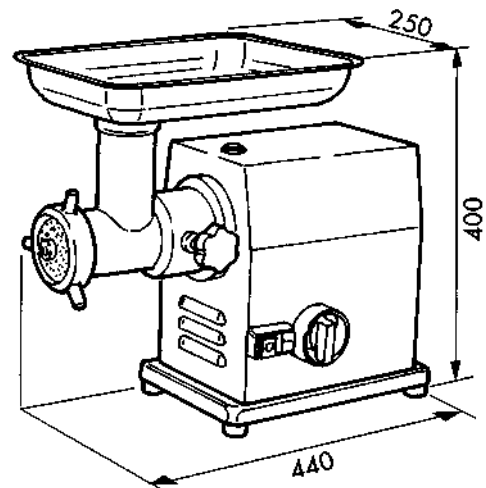

**Picadora de carne**

**Boca: 22. Cuerpo: acero inoxidable. Grupo picador: acero inoxidable. Cuchilla: autoafilante. Interruptor: invertidor de marcha. Potencia. 1 HP. Motor: trifásico 220/380. Producción: 130 kg/h**

**Meat mincer**

Outlet: 22. Body: stainless steel. Mincer set: stainless steel. Blade: self-sharpening. Switch: reverse switch. Power: 1 HP. Engine: three phase 220/380 V. Production: 130 Kg/h

**Hachoirs à viande**

Goulot: 22. Corps: acier inoxydable. Groupe hachoir: acier inoxydable. Couteau: auto aiguseur. Interrupteur: inverseur. Puissance 1 HP. Moteur: thiphasé 220/380 V. Production 130 kg/h

**Picadora de carne**

**Boca: 22. Cuerpo: acero inoxidable. Grupo picador: acero inoxidable. Cuchilla: autoafilante. Interruptor: invertidor de marcha. Potencia. 1 HP. Motor: monofásico 220 V. Producción: 130 kg/h**

**Meat mincer**

Outlet: 22. Body: stainless steel. Mincer set: stainless steel. Blade: self-sharpening. Switch: reverse switch. Power: 1 HP. Engine: one phase 220 V. Production: 130 Kg/h

**Hachoirs à viande**

Goulot: 22. Corps: acier inoxydable. Groupe hachoir: acier inoxydable. Couteau: auto aiguseur. Interrupteur: inverseur. Puissance 1 HP. Moteur: monophasé 220 V. Production 130 kg/h

Ref.	Peso Weight Poids	Euros
MP-22 EURO-T	23 kg	1406,00

Ref.	Peso Weight Poids	Euros
MP-22 EURO-M	23 kg	1450,00



**Despiece / Quartering / Dépeçage**

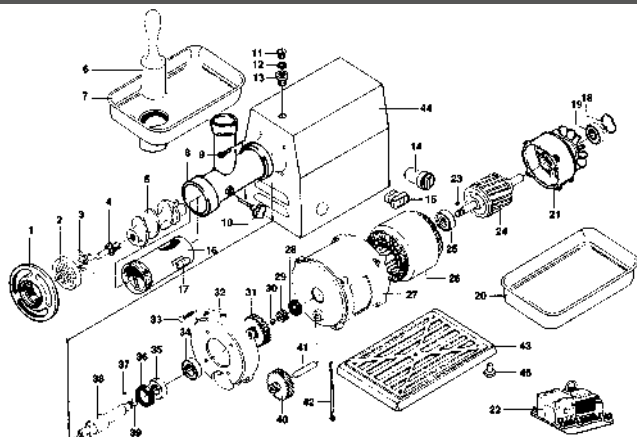

**Medidas / Size / Dimensions**

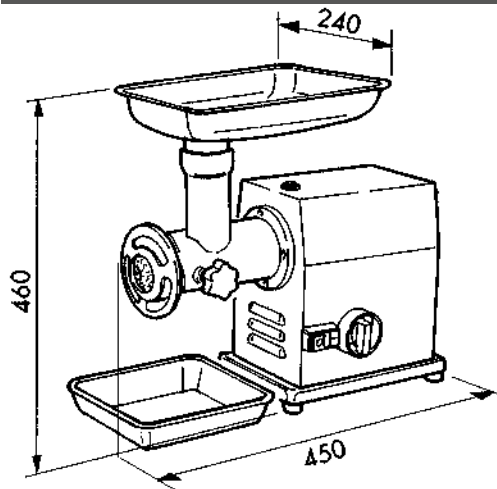

**Picadora de carne**

**Boca: 22. Cuerpo: acero inoxidable. Grupo picador: acero inoxidable. Cuchilla: autoafilante. Interruptor: invertidor de marcha. Potencia: 1,5 HP. Motor: trifásico 220/380V. Producción 250 kg/h**

**Meat mincer**

Outlet: 22. Body: stainless steel. Blade: self-sharpening. Switch: reverse switch. Power: 1,5 HP. Engine: triphase 220/380 V. Production: 250 kg/h.

**Hachoirs à viande**

Goulot 22. Corps: acier inoxydable. Groupe hachoir: acier inoxydable. Couteau: auto aiguiser. Interrupteur: inverseur. Puissance: 1,5 HP. Moteur: triphasé 220/380 V. Production: 250 kg/h

**Picadora de carne**

**Boca: 22. Cuerpo: acero inoxidable. Grupo picador: acero inoxidable. Cuchilla: autoafilante. Interruptor: invertidor de marcha. Potencia: 1,5 HP. Motor: monofásico 220 V. Producción 250 kg/h**

**Meat mincer**

Outlet: 22. Body: stainless steel. Blade: self-sharpening. Switch: reverse switch. Power: 1,5 HP. Engine: one phase 220 V. Production: 250 kg/h.

**Hachoirs à viande**

Goulot 22. Corps: acier inoxydable. Groupe hachoir: acier inoxydable. Couteau: auto aiguiser. Interrupteur: inverseur. Puissance: 1,5 HP. Moteur: monophasé 220 V. Production: 250 kg/h

Ref.	Peso Weight Poids	Euros
MP-22 MEC-T	30 kg	1742,00

Ref.	Peso Weight Poids	Euros
MP22 MEC-M	30 kg	1785,00



**Despiece / Quartering / Dépeçage**

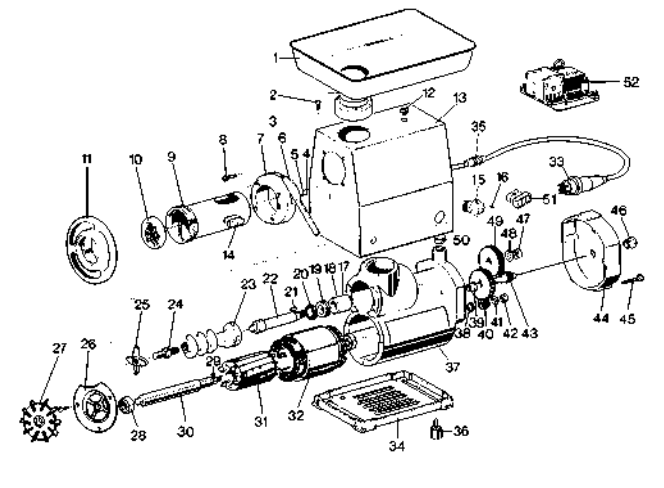

**Medidas / Size / Dimensions**

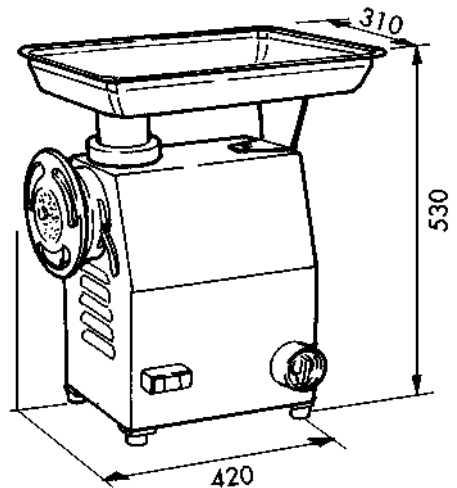



**Picadora de carne**

**Boca: 32. Cuerpo: acero inoxidable. Grupo picador: acero inoxidable. Cuchilla: autoafilante. Interruptor: invertidor de marcha. Potencia 3 HP. Motor trifásico 220/380 V. Producción: 500 kg/h.**

**Meat mincer**

Outlet: 32. Body: stainless steel. Mincer set: stainless steel. Blade: self-sharpening. Revers switch. Power: 3 HP. Engine: three phase 220/380 V. Production: 500 kg/h.

**Hachoirs à viande**

Goulot: 32. Corps: acier inoxydable. Groupe hachoir: acier inoxydable. Couteau: auto aiguiser. Interrupteur: inverseur. Puissance: 3 HP. Moteur: triphasé 220/380 V. Production: 500 kg

**Picadora de carne**

**Boca: 32. Cuerpo: acero inoxidable. Grupo picador: acero inoxidable. Cuchilla: autoafilante. Interruptor: invertidor de marcha. Potencia 2,5 HP. Motor monofásico 220 V. Producción: 500 kg/h.**

**Meat mincer**

Outlet: 32. Body: stainless steel. Mincer set: stainless steel. Blade: self-sharpening. Revers switch. Power: 2,5 HP. Engine: one phase 220 V. Production: 500 kg/h.

**Hachoir à viande**

Goulot: 32. Corps: acier inoxydable. Groupe hachoir: acier inoxydable. Couteau: auto aiguiser. Interrupteur: inverseur. Puissance: 2,5 HP. Moteur: monophasé 220 V. Production: 500 kg

Ref.	Peso Weight Poids	Euros
MP-32 MEC-T	47 kg	2500,00

Ref.	Peso Weight Poids	Euros
MP-32 MEC-M	47 kg	2545,00



**Despiece / Quartering / Dépeçage**

**Medidas / Size / Dimensions**

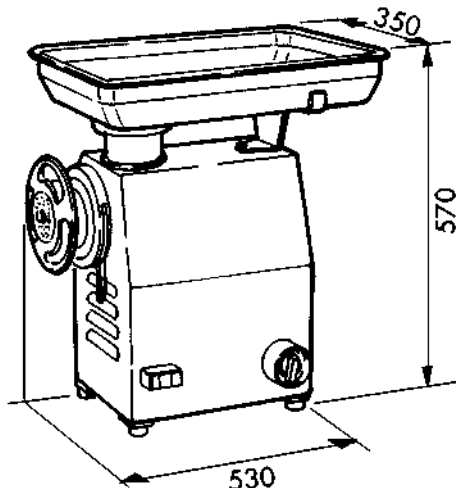
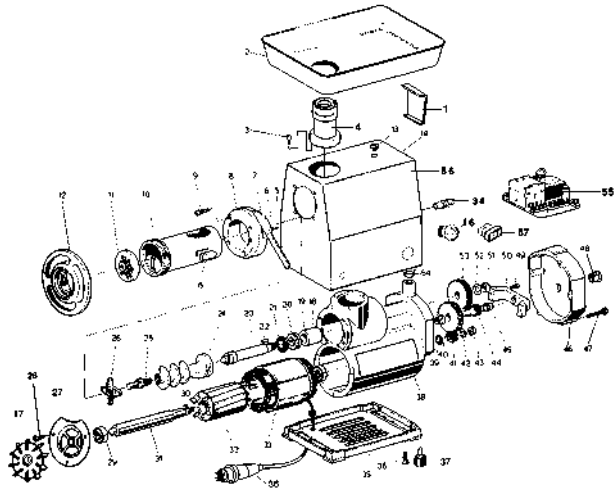

**Picadora refrigerada**

**Boca: 22. Cuerpo: acero inoxidable. Grupo picador: acero inoxidable. Cuchilla: autoafilante. Interruptor: invertidor de marcha. Potencia 1,5 HP. Grupo refrigerador hermético ventilado. Motor trifásico 220/380 V. Peso: 58 kg. Producción: 200 kg/h.**

*Refrigerated mincer*

Outlet: 22. Body: stainless steel. Mincer set: stainless steel. Blade: self-sharpening. Switch: reverse switch. Power: 1,5 HP. Veintilated hermetic refrigeration motor. Motor: three phase 220/380 V. Weight: 58 kg. Production: 200 kg.

*Hachoir réfrigéré*

Goulot: 22. Corps: acier inoxydable. Couteau: auto aiguiser. Interrupteur: inverseur. Puissance: 1,5 HP. Groupe réfrigérateur hermétique ventilé. Moteur triphasé 220/380 V. Poids: 58 kg. Production: 200 kg/h

Ref.	Euros
MP-22RE-T	3900,00



**Despiece / Quartering / Dépeçage**

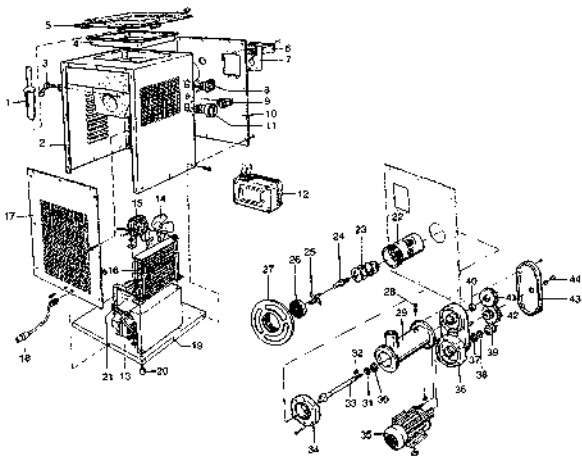

**Medidas / Size / Dimensions**

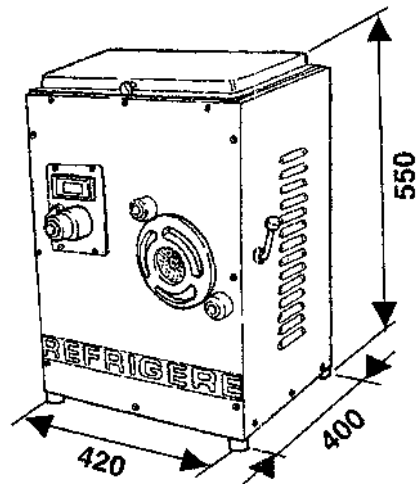

**Picadora refrigerada**

**Boca: 22. Cuerpo: acero inoxidable. Grupo picador: acero inoxidable. Cuchilla: autoafilante. Interruptor: invertidor de marcha. Potencia 3 HP. Grupo refrigerador hermético ventilado. Motor trifásico 220/380 V. Peso: 80 kg. Producción: 300 kg/h.**

*Refrigerated mincer*

Outlet: 22. Body: stainless steel. Mincer set: stainless steel. Blade: self-sharpening. Switch: reverse switch. Power: 3 HP. Veintilated hermetic refrigeration motor. Motor: three phase 220/380 V. Weight: 80 kg. Production: 300 kg.

*Hachoir réfrigéré*

Goulot: 22. Corps: acier inoxydable. Couteau: auto aiguiser. Interrupteur: inverseur. Puissance: 3 HP. Groupe réfrigérateur hermétique ventilé. Moteur triphasé 220/380 V. Poids: 80 kg. Production: 300 kg/h

Ref.	Euros
MP-32RE-T	4865,00



**Despiece / Quartering / Dépeçage**

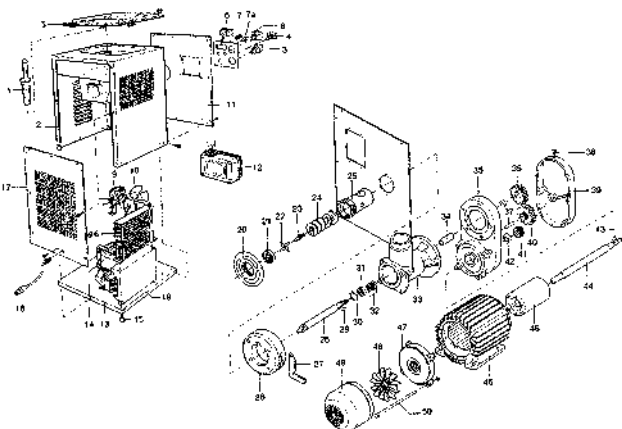

**Medidas / Size / Dimensions**

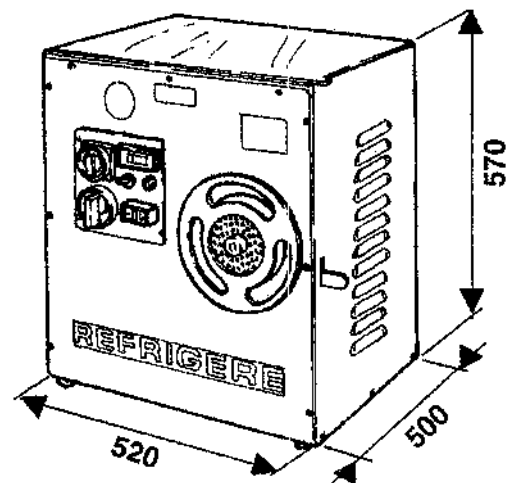



**Picadora inox monofase**  
**Boca 8. Cuerpo: acero inoxidable. Grupo picador: acero inoxidable. Cuchilla autoafilante. Motor ventilado. Potencia 0,5 HP. Producción: 70 kg/h.**

Stainless steel mincer one phase  
 Outlet: 8. Body: stainless steel. Mincer set: stainless steel. Self-sharpening blade. Ventilated engine. Power: 0,5 HP. Production: 70 kg.

*Hachoir inox monophase 8 HP 0,5*  
*Goulot: 8. Corps: acier inoxydable. Groupe hachoir: acier inoxydable. Lame: aiguseur. Moteur ventilé. Puissance: 0,5 HP. Production: 70 kg/h.*

**Despiece / Quartering / Dépeçage**

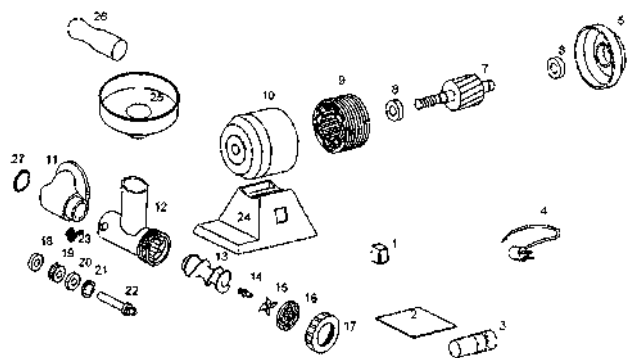

Ref.	Voltaje (V) Voltage (V) Voltage (V)	Medidas Size Dimensions	Peso Weight Poids	Euros
MP-8-M	220	27,5 x 25 x 35 cm	9 kg	500,00



**Cuchilla inox 8**

Stainless steel blade 8

*Lame inox 8*

Ref.	Euros
CP-8	16,00

**CP-8- - Placa inox picadora 8 con 2 chaveteros**

CP-8- - Stainless steel mincer plate 8

*CP-8- - Plaque inox hachoir 8*

Ref.	Diámetro Diameter Diamètre	Euros
CP-8-3	Ø 3 mm	27,00
CP-8-3,5	Ø 3,5 mm	25,00
CP-8-4	Ø 4 mm	23,00
CP-8-4,5	Ø 4,5 mm	23,00
CP-8-5	Ø 5 mm	22,00
CP-8-6	Ø 6 mm	22,00
CP-8-7	Ø 7 mm	22,00
CP-8-8	Ø 8 mm	22,00



**Cuchilla inox 12**

Stainless steel blade 12

*Lame inox 12*

Ref.	Euros
CP-12	12,00

**Placa inox 12**

Stainless steel plate 12

*Plaque inox 12*

Ref.	Diámetro Diameter Diamètre	Euros
CP-12-3	Ø 3 mm	24,00
CP-12- 3,5	Ø 3,5 mm	22,00
CP-12-4	Ø 4 mm	18,50
CP-12-4,5	Ø 4,5 mm	18,50
CP-12-5	Ø 5 mm	17,50
CP-12-6	Ø 6 mm	17,50
CP-12-7	Ø 7 cm	17,50
CP-12-8	Ø 8 mm	17,00



**2 chaveteros**

2 keyways

*2 rainures de clavette*

Ref.	Euros
CP-2C	7,50



**Cuchilla inox 22**

Stainless steel 22

*Lame inox 22*

Ref.	Euros
CP-22	15,00

**Placa inox 22**

Placa inox 22

*Plaque inox 22*

Ref.	Diámetro Diameter Diamètre	Euros
CP-22-3	Ø 3 mm	30,00
CP-22-3,5	Ø 3,5 mm	28,50
CP-22-4	Ø 4 mm	23,00
CP-22-4,5	Ø 4,5 mm	23,00
CP-22-5	Ø 5 mm	22,50
CP-22-6	Ø 6 mm	22,50
CP-22-7	Ø 7 mm	22,00
CP-22-8	Ø 8 mm	22,00



**2 chaveteros**

2 keyways

*2 rainures de clavette*

Ref.	Euros
CP-2C	7,50



**Cuchilla inox 32**

Stainless steel blade 32

Lame inox 32

Ref.	Euros
CP-32	17,00

**Placa inox 32**

Placa inox 32

Plaque inox 32

Ref.	Diámetro Diameter Diamètre	Euros
CP-32-3	Ø 3 mm	46,50
CP-32-3,5	Ø 3,5 mm	42,00
CP-32-4	Ø 4 mm	34,50
CP-32-4,5	Ø 4,5 mm	34,50
CP-32-5	Ø 5 mm	33,00
CP-32-6	Ø 6 mm	33,00
CP-32-7	Ø 7 mm	31,50
CP-32-8	Ø 8 mm	31,50

**2 chaveteros**

2 keyways

2 rainures de clavette

Ref.	Euros
CP-2C	7,50



**ACCESORIOS PICADORAS-EMBUTIDORAS-AFILADORAS | MINCER-SAUSAGE FILLER-SHARPENER ACCESSORIES | ACCESSOIRES HACHOIRS EMBOUTISSEUSES AIGUISEUSES**



**Empujador picadoras inyección**

Mincer pusher, injection

Poussoir hachoirs injection

Ref.	Diámetro Diameter Diamètre	Largo Long Longueur	Euros
A-35-11	Ø 5 cm	11 cm	12,50
A-35-13	Ø 5 cm	13 cm	12,50
A-35-15	Ø 5 cm	15 cm	12,50
A-35-26	Ø 4,5 cm	12,5 cm	11,50



**Empujador picadoras polietileno**

Polyethylene mincer pusher

Poussoir hachoirs polyéthylène

Ref.	Diámetro Diameter Diamètre	Largo Long Longueur	Euros
A-36-11	Ø 5 cm	11 cm	40,00
A-36-13	Ø 5 cm	13 cm	43,00
A-36-15	Ø 5 cm	15 cm	48,00



**Cintas de sierra para carne**  
**Características 16 x 0,4 mm. Tamaño del diente 7 mm. Corte de carne fresca sin hueso o pequeños huesos**

Meat band saws  
 Features 16 x 0.4 mm. Tooth size 7 mm. Cut of fresh meat without bone or small bones

*Scies à ruban de viande*  
*Caractéristiques 16 x 0.4 mm. Taille de dent 7 mm. Couper de la viande fraîche sans os ou petits os*

Ref.	Largo Long Longueur	Unidades Units Unités	Euros
SCA-1600	1600 mm	4	39,00
SCA-1740	1740 mm	4	42,00
SCA-1750	1750 mm	4	42,00
SCA-1985	1985 mm	4	43,50
SCA-2120	2120 mm	4	45,00
SCA-2340	2340 mm	4	46,50
SCA-2520	2520 mm	4	51,00
SCA-2930	2930 mm	4	54,00

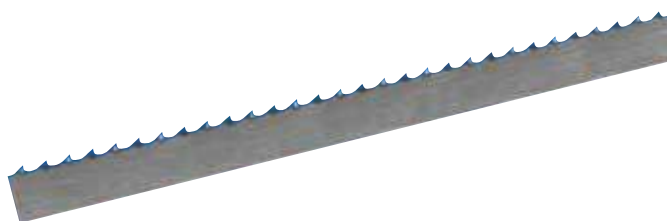

**Cintas de sierra para hueso**  
**Características 16 x 0,50 mm. Tamaño del diente 6,35 mm (4 dientes pulgada). Corte de hueso**

Bone saw bands  
 Characteristics 16 x 0,50 mm. Tooth size 7 mm (4 teeth inch). Bone cutting

*Scies à ruban pour l'os*  
*Caractéristiques 16 x 0,50 mm. Taille de dent 7 mm (4 dents pouces). Coupe d'os*

Ref.	Largo Long Longueur	Unidades Units Unités	Euros
SHU-1600	1600 mm	4	45,50
SHU-1740	1740 mm	4	48,00
SHU-1750	1750 mm	4	48,00
SHU-1985	1985 mm	4	53,00
SHU-2120	2120 mm	4	55,00
SHU-2340	2340 mm	4	57,00
SHU-2520	2520 mm	4	62,00
SHU-2930	2930 mm	4	71,50

**Cintas de sierra para congelados**  
**Características 16 x 0,56 mm. Tamaño diente 8,46 mm (3 dientes/ pulgada). Corte de carne, pescado y congelados**

Saw bands for frozen  
 Characteristics 16 x 0.56 mm. Tooth size 8.46 mm (3 teeth / inch).  
 Cut of meat, fish and frozen

*Rubans de scie pour congelés*  
*Caractéristiques 16 x 0.56 mm. Taille de denture 8.46 mm (3 dents / pouce). Coupe de viande, poisson et congelé*

Ref.	Largo Long Longueur	Unidades Units Unités	Euros
SCO-1600	1600 mm	4	45,50
SCO-1740	1740 mm	4	48,00
SCO-1750	1750 mm	4	48,00
SCO-1985	1985 mm	4	53,00
SCO-2120	2120 mm	4	55,00
SCO-2340	2340 mm	4	57,00
SCO-2520	2520 mm	4	62,00
SCO-2930	2930 mm	4	71,50

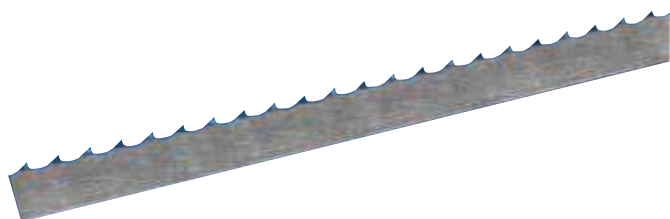

Características técnicas Technical specifications Caractéristiques techniques	MC-E300	MC-E350	MC-M350
Cuchilla alemana German blade Lame allemande	300	350	350
Potencia Power Pussance	0.37 KW / 0.5 HP	0.37 KW / 0.5 HP	0.37 KW / 0.5 HP
Voltaje Voltage Voltage	230 V	230 V	230 V
Espesor corte Cutting thickness Dimensions ext.	0-15	0-15	0-24
Medidas exteriores Exterior measurement Mesures extérieures	519 x 620 x 450	560 x 695 x 520	590 x 840 x 550
Medidas base apoyo A-L Base size Dimensions base	360 x 480	390 x 540	480 x 605
Peso Weight Poids	30 kg	38 kg	40 kg
Afilador incorporado Sharpener Aiguiseur	SI / YES / OUI	SI / YES / OUI	SI / YES / OUI
Transmisión Transmission Transmission	CORREA / BELT / COURROIE	CORREA / BELT / COURROIE	DIRECTA
Aluminio anodizado anticorrosivo Aluminium anodized anticorrosive Aluminium anodisé anticorrosif	SI / YES / OUI	SI / YES / OUI	SI / YES / OUI
Capacidad corte (grueso) Slicing capacity (thickness) Capacité de coupe (épaisseur)	170 x 250	200 x 280	185 x 300
Precio P.V.P Retail price Prix conseillé	<b>2305,00 €</b>	<b>2651,00 €</b>	<b>3888,00 €</b>



MC-E300  
MC-E350



MC-M350



Características técnicas Technical specifications Caractéristiques techniques	MC-220-AF	MC-250-C	MC-300-E	MC-350-I
Cuchilla alemana German blade Lame allemande	220	250	300	350
Potencia Power Pissance	186 W / 0,25 HP	225 W / 0,30 HP	260 W / 0,35 HP	372 W / 0,50 HP
Voltaje Voltage Voltage	230 V	230 V	230 V	230 V
Espesor corte Cutting thickness Dimensions ext.	0-15	0-16	0-16	0-16
Medidas exteriores Exterior measurement Mesures extérieures	405 x 580 x 340	425 x 620 x 370	595 x 650 x 440	585 x 890 x 480
Medidas base apoyo A-L Base size Dimensions base	280 x 415	390 x 440	240 x 465	415 x 580
Peso Weight Poids	13,5 kg	15,5 kg	23 kg	36 kg
Afilador incorporado Sharpener Aiguiseur	SI / YES / OUI	SI / YES / OUI	SI / YES / OUI	SI / YES / OUI
Transmisión Transmission Transmission	CORREA / BELT / COURROIE	CORREA / BELT / COURROIE	CORREA / BELT / COURROIE	CORREA / BELT / COURROIE
Aluminio anodizado anticorrosivo Aluminium anodized anticorrosive Aluminium anodisé anticorrosif	SI / YES / OUI	SI / YES / OUI	SI / YES / OUI	SI / YES / OUI
Capacidad corte (grueso) Slicing capacity (thickness) Capacité de coupe (épaisseur)	160 x 190	190 x 220	220 x 220	360 x 310
Precio P.V.P Retail price Prix conseillé	<b>804,00 €</b>	<b>960,00 €</b>	<b>1398,00 €</b>	<b>2270,00 €</b>



MC-220-AF



MC-250-C



MC-300-E



MC-350-I



**Cortadora fiambres manual 250. Espesor corte 0+2.  
Capacidad corte (Grueso) de 150 x 185 mm. Posición sobremesa.**

Cold cuts cutter manual 250. Cut thickness 0+2.  
Cutting capacity (thickness) 150 x 185 mm. Position desktop.

*Coupante charcuterie manual 250. Épaisseur de coupe 0+2.  
Capacité coupure (épaisseur) 150 x 185 mm. Position sur table.*

Ref.	Euros
MC-250-VOL	3909,00



**Cortadora fiambres manual 300. Espesor corte 0+2.  
Capacidad corte (Grueso) de 190 x 230 mm. Posición sobremesa.**

Cold cuts cutter manual 300. Cut thickness 0+2.  
Cutting capacity (thickness) 190 x 230 mm. Position desktop.

*Coupante charcuterie manual 300. Épaisseur de coupe 0+2.  
Capacité coupure (épaisseur) 190 x 230 mm. Position sur table.*

Ref.	Euros
MC-300-VOL	4250,00



**Soporte columna para MC-250/300-VOL**

Column support for MC-250/300-VOL

*Support colonne pour MC-250/300-VOL*

Ref.	Euros
MC-2530	1456,00

**Ralladora mozzarella**

**Cuerpo: acero inoxidable. Potencia: 0,35 HP. Motor monofásico 220 V. Peso 14 kg. Producción: 50 kg/h.**

Mozzarella grater  
Body: stainless steel. Power: 0,35 HP. Motor: one phase 220 V.  
Weight : 14 kg. Production: 50 Kg/h.

*Râpe à fromage*

*Corps: acier inoxydable. Puissance 0,35 HP. Moteur: monophasé 220 V. Poids: 14 kg. Production: 50 kg/h.*



Ref.	Euros
MPQ-MOZZARELLA	1020,00



**Campana agujero 2 mm. para queso en hilo**

Cone shaped grater with 2 mm holes for shredded cheese

*Cloche trou 2 mm pour fromage filé*

Ref.	Euros
MPQ-MOZ-15	94,00



**Despiece / Quartering / Dépeçage**

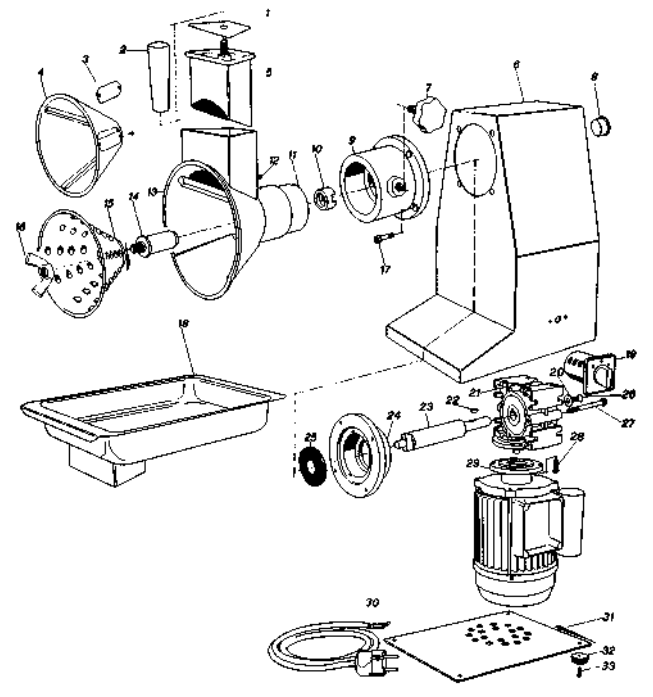

**Ralladora motor estanco HP 0,5, monofase 220 V. Potencia 600 W / Producción 50 kg/h**

Grater protected engine HP 0,5, one phase 220 V. Power 600 W / Production 50 kg/h

Râpe moteur protégé HP 0,5, monophasé 220 V. Puissance 600 W / Production 50 kg/h

**Incluye disco 3 m/m**

Includes 3m/m disc

Comprend un disque de 3 m/m



Ref.	Medidas Size Dimensions	Peso Weight Poids	Euros
MPQ-02	42 x 25 x 36 cm	14,5 kg	1168,00



**Disco parmesano para ref. MPQ-02**

Parmesan disk for ref. MPQ-02

Disque parmesan pour réf. MPQ-02

Ref.	Euros
DR-0	75,00

**Disco agujero para ref. MPQ-02**

Hole disk for ref. MPQ-02

Disque trou pour réf MPQ-02

Ref.	Tipo Type Type	Euros
DR-2	2 mm	75,00
DR-3	3 mm	75,00
DR-4	4 mm	75,00
DR-6	6 mm	75,00
DR-8	8 mm	75,00

**Disco hielo para ref. MPQ-02**

Ice disk for ref. MPQ-02

Disque glace pour réf. MPQ-02

Ref.	Euros
DRH	125,00



**EXPRIMIDOR CÍTRICOS | CITRUS JUICER | PRESSE-CITRON**

**Exprimidor cítricos Santos n° 10. Potencia 230 W. Producción 30 L/H**

Citrus juicer Santos n° 10. Power 230 W. Production 30 L/H

Presse-citron Santos n° 10. Puissance 230 W. Production 30 L/H

Ref.	Medidas Size Dimensions	Peso Weight Poids	Euros
MSE-10	30 x 20 x 38 cm	9,5 kg	828,00

**Máquina ralladora-cortadora multifunción**

**Cuerpo: acero inoxidable y aleación especial. Potencia: HP 0,75. Motor: trifásico 230/380 V. Peso 20 kg. Producción: 150-300 kg/h**

Multi purpose grater-slicer machine

Body: stainless steel with special alloy. Power: 0,75 HP. Engine: three phase 230/380 V. Weight: 20 Kg. Production: 150-300 kg/h

*Machine à râpe-découpoir multifonction*

*Corps: acier inoxydable et alliage spécial. Puissance: 0,75 HP.*

*Moteur: triphasé 230-380 V. Poids: 20 kg. Production : 150-300 kg/h*

**Máquina ralladora-cortadora multifunción**

**Cuerpo: acero inoxidable y aleación especial. Potencia: HP 0,75. Motor: monofásico 230 V. Peso 20 kg. Producción: 150-300 kg/h**

Multi purpose grater-slicer machine

Body: stainless steel with special alloy. Power: 0,75 HP. Engine: One phase 230 V. Weight: 20 Kg. Production: 150/300 kg/h

*Machine à râpe-découpoir multifonction*

*Corps: acier inoxydable et alliage spécial. Puissance: 0,75 HP.*

*Moteur: monophasé 230V. Poids: 20 kg. Production : 150-300 kg/h*

Ref.	Euros
MPQV-5-T	1680,00

Ref.	Euros
MPQV-5-M	1680,00



**Despiece / Quartering / Dépeçage**

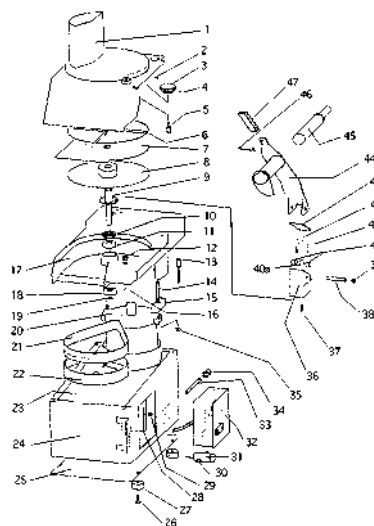

**Medidas / Size / Dimensions**

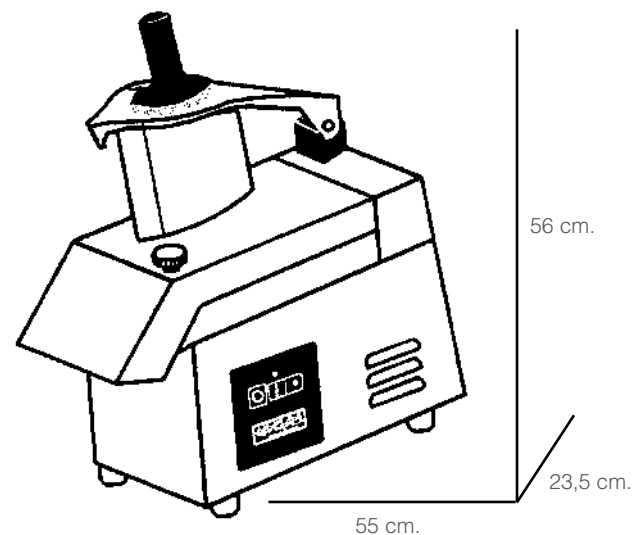

**DISCOS RALLADORES HILO-POLVO PARA QUESO, VERDURAS, PAN Y FRUTOS SECOS | STRING-FINE SHRED GRATER DISKS FOR CHEESE, VEGETABLES, BREAD CRUMBS AND NUTS | DISQUES À RÂPER FIL POUVRE POUR FROMAGE, LÉGUMES, PAIN ET FRUITS SECS**

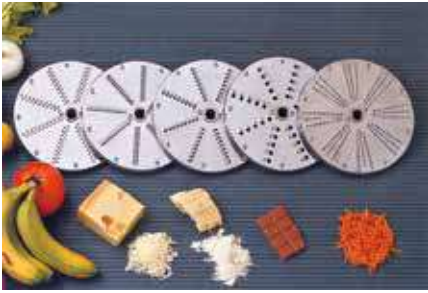

**Disco para hilo**

Disk for slices

*Disque pour rondelles*

Ref.	Tipo Type	Euros
DZ-2	2 mm	95,00
DZ-3	3 mm	95,00
DZ-4	4 mm	95,00
DZ-7	7 mm	95,00

**Disco para polvo**

Fine shred disk

*Disque pour poudre*

Ref.	Euros
DV	95,00

**DISCO PARA CORTE EN RODAJAS | SLICING DISKS | DISQUES POUR COUPER EN RONDELLES**



**Disco para rodajas**

Disk for slice

*Disque pour rondelles*

Ref.	Tipo Type	Euros
DE-1	1 mm	98,00
DE-2	2 mm	98,00
DE-3	3 mm	98,00
DE-4	4 mm	120,00



**Disco para rodajas**

Disk for slice

*Disque pour rondelles*

Ref.	Tipo Type	Euros
DE-6	6 mm	120,00
DE-8	8 mm	120,00
DE-10	10 mm	120,00
DE-14	14 mm	120,00



**Accesorios rejilla a tiras (patatas fritas)**

Strip slicer accessories (fried chips)

*Accessoires grille en lamelles (frites)*

Ref.	Tipo Type	Euros
DB-6	6 mm (DE-6)	140,00
DB-8	8 mm (DE-8)	140,00
DB-10	10 mm (DE-10)	140,00



**Accesorios rejilla cubos**

Dicing accessories

*Accessoires grille dés*

Ref.	Tipo Type	Euros
DD-8	8 x 8 mm (DE-8)	180,00
DD-10	10 x 10 (DE-10)	180,00
DD-20	20 x 20 mm (DE-14)	180,00

**DISCO CURVO CORTE BLANDO EN RODAJAS TOMATES, NARANJA, LIMÓN, PLÁTANO, ETC | CURVED DISK, SLFT CUT IN SLICES, TOMATOES, ORANGE, LEMON, BANANA, ETC. | DISQUE COURBE DÉCOUPE TENDRE EN RONDELLES, TOMATES, ORANGE, CITRON, BANANE, ETC.**



**Disco curvado corte blando**

Curved disk soft cut

*Disque courbe découpe tendre*

Ref.	Tipo Type	Euros
DS-1	1 mm	120,00
DS-2	2mm	120,00
DE-5	5 mm	120,00



**Disco para rodajas onduladas**

Disk for wavy slices

*Disque pour rondelles ondulées*

Ref.	Díámetro Diameter Diamètre	Euros
DH-2,5	Ø 2,5 mm	140,00
DH-4	Ø 4 mm	140,00
DH-6	Ø 6 mm	140,00
DH-8	Ø 8 mm	140,00
DH-10	Ø 10 mm	140,00

**DISCO DE CORTE REGULABLE | ADJUSTABLE SLICER DISK | DISQUE DÉCOUPE RÉGLABLE**



**Disco corte en rodajas regulable de 1 a 8 mm**

Kisk for adjustable slices 1 to 8 mm

*Disque pour rondelles réglable de 1 à 8 mm*

Ref.	Euros
DX-1	200,00

**ACCESORIOS DISCOS | DISKS ACCESSORIES | DISQUES ACCESSOIRES**



**Soporte portadiscos**

Disk-rack

*Support porte-disques*

Ref.	Medidas Size Dimensions	Euros
DA-18	39,5 x 25,6 x 10 cm	70,50

**Disco expulsor para ref. MPQV-5**

Disk remover for ref MPQV-5

*Disque expulseur pour réf. MPQV-5*

Ref.	Euros
DA-1	30,00



**Cutter 3 L**  
**Cuerpo: acero inoxidable. Potencia : 480W. Motor: monofásico 230 V. Velocidad variable: 900-2200 rpm. Peso: 11 kg. Dimensiones cubeta: 18 Ø x 10,5 cm altura. Incluye cuchilla lisa.**

Cutter 3 L  
 Body: stainless steel. Power 480W. Engine: one phase 230 V. Variable speed: 900/2200 rpm. Weight: 11 kg. Bowl sizes: 18 Ø x 10,5 cm height. Includes smooth blade

Cutter 3 L  
 Corps: acier inoxydable. Puissance 480W. Moteur: monophasé 230 V. Vitesse variable: 900/2200 rpm. Poids: 11 kg. Dimensions bac: 18 Ø x 10,5 cm hauteur. Comprend lame lisse.

Ref.	Euros
MC-3	1316,00

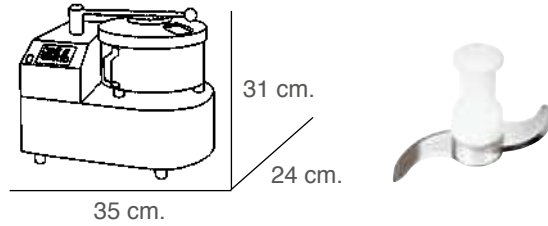

**MC-CL-X - Cuchilla lisa afilada para triturar**

MC-CL-X - Smooth blade sharpened for grinding

MC-CL-X - Lame lisse aiguisée pour triturer



**MC-CD-X - Cuchilla dentada para triturar**

MC-CD-X - Tooth blade for grinding

MC-CD-X - Lame dentelée pour triturer



**MC-CP-X - Cuchilla perforada para batir y amasar**

MC-CP-X - Perforated blade for mixing and kneading

MC-CP-X - Lame perforée pour battre et pétrir

Ref.	Tipo Type	Euros
MC-CL-3	MC-3	108,00
MC-CL-5	MC-5, MC-8	163,00

Ref.	Tipo Type	Euros
MC-CD-3	MC-3	108,00
MC-CD-5	MC-5, MC-8	163,00

Ref.	Tipo Type	Euros
MC-CP-3	MC-3	108,00
MC-CP-5	MC-5, MC-8	163,00



**Puré de tomate / Purée de tomate / Purée de tomate: 60 seg.**

**Mayonesa / Mayonnaise / Purée de tomate: 130 seg.**

**Perejil, ajo, cebolla, pimiento triturado / Parsley, garlic, onion pepper grinded / Persil, ail, oignon et le poivron moulu: 15 seg.**

**Pan rallado / Breadcrumbs / Chapelure: 60 seg.**

**Chocolate / Chocolate / Chocolat : 60 seg.**



**Frutos secos triturados / Dried fruits grinded / Fruits secs broyés: 20 seg.**

**Mozzarella para pizza / Pizza mozzarella / Mozzarella pour pizza: 10 seg.**

**Carne triturada / Grinded meat / Viande broyée: 10 seg.**

**Amasijos tiernos para pastelería / Bakery mixture / Pâtisserie: 60 seg.**

**Puré de verduras / Purée vegetables / Purée de légumes: 5 seg.**



**Cutter 5 L**

**Cuerpo: acero inoxidable. Potencia : 960W. Motor: monofásico 230 V. Velocidad variable: 900-2200 rpm. Peso: 18 kg. Dimensiones cubeta: 24 Ø x 12 cm altura. Incluye cuchilla lisa.**

**Cutter 5 L**

Body: stainless steel. Power 960W. Engine: one phase 230 V. Variable speed: 900/2200 rpm. Weight: 18 kg. Bowl sizes: 24 Ø x 12 cm height. Includes smooth blade

**Cutter 5 L**

Corps: acier inoxydable. Puissance 960W. Moteur: monophasé 230 V. Vitesse variable: 900/2200 rpm. Poids: 18 kg. Dimensions bac: 24 Ø x 12 cm hauteur. Comprend lame lisse.

Ref.	Euros
MC-5	1846,00

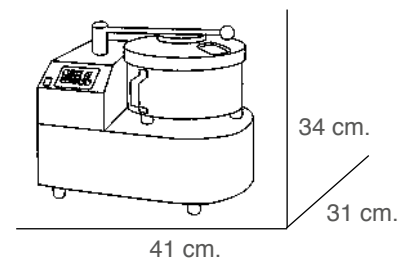
**Cutter 8 L**

**Cuerpo: acero inoxidable. Potencia : 960W. Motor: monofásico 230 V. Velocidad variable: 900-2200 rpm. Peso: 19 kg. Dimensiones cubeta: 24 Ø x 18 cm altura. Incluye cuchilla lisa.**

**Cutter 8 L**

Body: stainless steel. Power 960W. Engine: one phase 230 V. Variable speed: 900/2200 rpm. Weight: 19 kg. Bowl sizes: 24 Ø x 18 cm height. Includes smooth blade

**Cutter 8 L**

Corps: acier inoxydable. Puissance 960W. Moteur: monophasé 230 V. Vitesse variable: 900/2200 rpm. Poids: 19 kg. Dimensions bac: 24 Ø x 18 cm hauteur. Comprend lame lisse.

Ref.	Euros
MC-8	1978,00

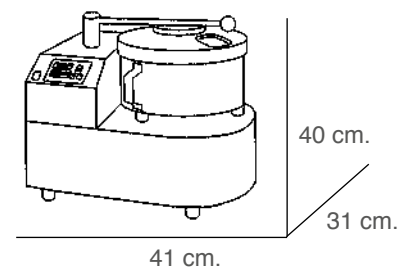

**0 3** ENTERNECEDOR DE CARNE BOSTON | MEAT TENDERIZER | ATTENDRISSANT

**Máquina enternecedor de carne**  
**Cuchillas desmontables, fácil limpieza.**

**Potencia: 0,50 HP. Cuchillas acero-inox con 180 microcortes por Dm<sup>2</sup>. Motor monofásico 220 V.**

Meat tenderizer  
Detachable blades, easy cleaning.

Power: 0,50 HP. Stainless steel blades with 180 micro cuts per Dm<sup>2</sup>.  
Motor: one phase 220 V.

Attendrisseur viande  
Couteaux séparables, nettoyage facile.

Puissance: 0,50 HP. Couteaux acier inox avec 180 micro entailles par Dm<sup>2</sup>. moteur: monophasé 220 V.

Ref.	Medidas Size Dimensions	Peso Weight Poids	Euros
MPE-18	41 x 19 x 40 cm	17 kg	2450,00



**Molino pimienta**  
**Potencia: 1 HP. Producción: 12 kg/h**

Pepper mill  
 Power: 1 HP. Production: 12 kg/h

*Moulin à poivre*  
*Puissance: 1 HP. Production: 12 kg/h*



Ref.	Medidas Size Dimensions	Peso Weight Poids	Euros
MPP-10	22 x 34 x 61 cm	12 kg	896,00



**AFILADORA | SHARPENER | AIGUISEUR**

**Afilador mini**  
**Afilado: 2 piedras: 1 afilado y 1 pulido**

Mini sharpener  
 Sharpening: 2 stones: 1 sharp. & 1 polish

*Aiguiser mini*  
*Aiguisage: 2 pierres: 1 aiguisée et 1 polie.*



Ref.	Medidas Size Dimensions	Voltaje (V) Voltage (V) Voltage (V)	Euros
A-198	22 x 9 x 8 cm	220	156,00

**Juego 2 piedras con eje para ref. A-198**

Stone set for ref. A-198

*Ensemble 2 pierres pour réf. A-198*



Ref.	Euros
A-198-1	42,00



**0 3 AFILADORA | SHARPENER | AIGUISEUR**

**Máquina afilar banda**

**Potencia: 0,35 HP. Revoluciones: 2800 rpm. Motor: monofásico 220 V.**

Band-sharpening machine

Power: 0.35 HP. Revoluciones: 2800 rpm. Engine: One phase 220 V.

Machine à aiguiser bande

Puissance: 0,35 HP. Révolutions: 2800 rpm. Moteur: Monophasé 220 V.

Ref.	Medidas Size Dimensions	Voltaje (V) Voltage (V) Voltage (V)	Peso Weight Poids	Euros
A-200	33 x 28 x 40 cm	220	9 kg	615,00

**Afilar / Sharpen / Aiguiser**



**Pulir / Polish / Polir**



**Banda afilar para ref. A-200**

Sharpening band for ref. A-200

Bande aiguiser pour réf. A-200

Ref.	Euros
A-200-13X Circonio	6,50
A-200-13	5,00

**Disco pulir para ref. A-200**

Polishing disk for ref. A-200

Disque polir pour réf. A-200

Ref.	Euros
A-200-33	61,00

**Despiece / Quartering / Dépeçage**

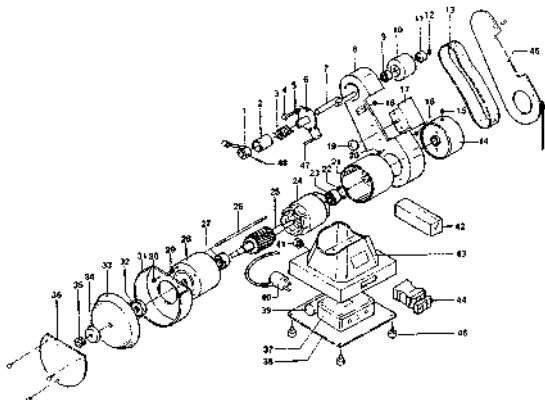

0

4

**Maquinas retractilar, Film, Dispensadores de film, Dispensador papel aluminio, Soldadoras de bolsas, Máquina sellar, Máquina vacío, Parrilla envasadora, Bolsas vacío, Termoselladora.**

---

Wrapping machines, Film, Film dispensers, Aluminium foil dispenser, Bag sealer, Sealer machine, Vacuum machine, Packaging grill, Vacuum bags, Thermo sealer.

---

*Machine à retractiler, Film, Dispensateurs film, Dispensateur papier aluminium, Scelleuse de sacs, Machine à sceller, Machine vide, Grill à sceller, Sacs sous vide, Thermo machine.*

**87-100**



**Máquina retractilar, acero-inox**  
**Con placa de calor. Interruptor para placa calor ON/OFF. Interruptor para resistencia corte ON/OFF.**

Wrapping machine, stainless steel  
 Featuring heat plate. Heat plate ON/OFF switch.ON/OFF switch for cut resistance.

*Machine à rétractiler, acier-inox*  
*Avec plaque de chauffage. Interrupteur pour plaque de chauffage ON/OFF. Interrupteur pour résistance découpe ON/OFF.*

Ref.	Medidas Size Dimensions	Resistencia corte Cut resistance Résistance à la découpe	Bobina film Film roll Bobine film	Voltaje (V) Voltage (V) Voltage (V)	Euros
MR-4-ECO	59 x 48,5 x 13,5 cm	46 cm	MR-40/45	220	220,00
MR-4-500-ECO	59 x 52 x 13,5 cm	50 cm	MR-40/45/47	220	281,00



**Máquina retractilar, acero-inox**  
**Con placa de calor. Interruptor para placa calor ON/OFF. Interruptor para resistencia corte ON/OFF.**

Wrapping machine, stainless steel  
 Featuring heat plate. Heat plate ON/OFF switch.ON/OFF switch for cut resistance.

*Machine à rétractiler, acier-inox*  
*Avec plaque de chauffage. Interrupteur pour plaque de chauffage ON/OFF. Interrupteur pour résistance découpe ON/OFF.*

Ref.	Medidas Size Dimensions	Resistencia corte Cut resistance Résistance à la découpe	Voltaje (V) Voltage (V) Voltage (V)	Bobina film Film roll Bobine film	Euros
MR-4	59 x 48,5 x 13,5 cm	45 cm	220	MR-40/45	268,00
MR-4-500	59 x 52 x 13,5 cm	50 cm	220	MR-40/45/47	329,00
MR-4-600	65 x 62 x 13,4 cm	60 cm	220	MR-40/45/46/47	444,00



**Máquina retractilar**  
**Con placa de calor. Interruptor para placa calor ON/OFF. Interruptor para resistencia corte ON/OFF. Ideal para espacios reducidos al llevar la bobina de film en su interior.**

Wrapping machine  
 Featuring heat plate. Heat plate ON/OFF switch.ON/OFF switch for cut resistance. Ideal for small spaces because it incorporates the film roll inside.

*Machine à rétractiler*  
*Avec plaque de chauffage. Interrupteur pour plaque de chauffage ON/Of. Interrupteur pur résistance découpe ON/OFF. Idéal pour les petits espaces car il intègre le rouleau de film à l'intérieur.*

Ref.	Medidas Size Dimensions	Bobina film Film roll Bobine film	Resistencia corte Cut resistance Résistance à la découpe	Euros
MR-1	48 x 45 x 19 cm	MR-20/30	45 cm	298,00
MR-1-ECO	48 x 45 x 19 cm	MR-20/30	46 cm	245,00



**Máquina retractor**  
Sin placa de calor. Interruptor ON/OFF.

Wrapping machine  
Without heat plate. Heat plate ON/OFF.

Machine à rétractiler  
Sans plaque de chauffage. Interrupteur pour plaque de chauffage ON/OFF.

Ref.	Medidas Size Dimensions	Resistencia corte Cut resistance Résistance à la découpe	Bobina film Film roll Bobine film	Voltaje (V) Voltage (V) Voltage (V)	Euros
MR-2	48,5 x 27 x 17,5 cm	45 cm	MR-20	220	229,00



**Máquina retractor**  
Sin placa de calor. Interruptor ON/OFF.

Wrapping machine  
Without heat plate. Heat plate ON/OFF switch. **BOBINAS FILM | FILM ROLLS | BOBINES FILM**

Machine à rétractiler  
Sans plaque de chauffage. Interrupteur pour plaque de chauffage ON/OFF.

Ref.	Medidas Size Dimensions	Resistencia corte Cut resistance Résistance à la découpe	Bobina film Film roll Bobine film	Voltaje (V) Voltage (V) Voltage (V)	Euros
MR-3	34,5 x 27 x 17,5 cm	30 cm	MR-30	220	189,00



**Bobinas de film**

Film rolls

Bobines film

Ref.	Medidas Size Dimensions	Euros
MR-20	40 x 500 cm	29,00
MR-30	30 x 500 cm	22,00
MR-40	40 x 1500 cm	67,00
MR-45	45 x 1500 cm	75,00
MR-47	50 x 1500 cm	92,00
MR-46	60 x 1500 cm	112,00
MR-49	90 x 1500 cm	103,00
MR-50	30 x 300 cm	9,80
MR-60	45 x 300 cm	14,70



**Dispensador inox con cuchilla**  
**Posición sobre mesa ó pared.**

Stainless steel dispenser with cutter  
Free standing or attached to wall.

*Distributeur inox avec lame*  
*Pose sur table ou mur.*

Ref.	Medidas Size Dimensions	Bobina film Film roll Bobine film	Euros
MR-10	36 x 12,5 x 9 cm	MR-50	71,00
MR-11	50 x 12,5 x 9 cm	MR-60	84,00
MR-10-1	<b>Cuchilla para / Blade for</b> <i>/ Lame pour</i>		10,00



**Dispensador inox con cuchilla**  
**Posición sobre mesa.**

Stainless steel dispenser with cutter  
Free standing or attached.

*Distributeur inox avec lame*  
*Pose sur table.*

Ref.	Medidas Size Dimensions	Bobina film Film roll Bobine film	Euros
MR-12	50 x 22 x 9 cm	MR-45	170,00
MR-13	63 x 22 x 9 cm	MR-46/47	223,00
MR-14	95 x 22 x 9 cm	MR-49	445,00



**Dispensador acero inox**  
**Posición sobre mesa ó pared.**

Stainless steel dispenser  
Free standing or attached to wall.

*Distributeur acier inox*  
*Pose sur table ou mur.*

Ref.	Medidas Size Dimensions	Bobina film Film roll Bobine film	Euros
MRI-5	34 x 16 x 9 cm	MR-50	73,00
MRI-6	49 x 16 x 9 cm	MR-60	77,00



**Dispensador con tapa acero-inox**  
**Posición sobre mesa ó pared.**

Dispenser with stainless steel top  
Free standing or attached to wall.

*Distributeur avec couvercle acier inox*  
*Pose sur table ou mur.*

Ref.	Medidas Size Dimensions	Bobina film Film roll Bobine film	Euros
MRIT-5	34 x 16 x 12 cm	MR-50	98,00
MRIT-6	46 x 16 x 12 cm	MR-60	105,00



**MR-5\_6 - Dispensador metálico**  
**Con kit de cuchilla para corte.**

MR-5\_6 - Metal dispenser  
With cutting blade kit.

*MR-5\_6 - Dispensador de metálico*  
*Avec coupe kit de lame.*

Ref.	Medidas Size Dimensions	Bobina film Film roll Bobine film	Euros
MR-5	34 x 16 x 9 cm	MR-50	47,00
MR-6	49 x 16 x 9 cm	MR-60	54,00





**Dispensador inox papel aluminio 45 cm inox**

Stainless steel dispenser for 45 cm aluminium

*Dispensateur inox pour aluminium de 45 cm*

Ref.	Euros
MR-9	29,00

**Papel aluminio**

Aluminium foil

*Papier aluminium*

Ref.	Medidas Size Dimensions	Euros
MR-80	29 x 300 cm	44,00
MR-90	40 x 300 cm	65,00



**SOLDADORAS DE BOLSAS | BAG SEALER | SCELLEUSE DE SACS**

**Soldadora de bolsas**

**Con regulador de temperatura, posición sobremesa.**

Bag sealer

With temperature regulator, positioning free standing.

*Scelleuse de sacs*

*Régulateur de température, position surtable.*

Ref.	Maximum seal Maximum seal Maximum seal	Voltaje (V) Voltage (V) Voltage (V)	Euros
SB-200	20 cm	220	165,00
SB-300	30 cm	220	194,00
SB-400	40 cm	220	224,00
SB-500	50 cm	220	345,00



**Soldadora de bolsas**

**Con regulador de temperatura.**

Bag sealer

With temperature regulator.

*Scelleuse de sacs*

*Régulateur de température.*

Ref.	Maximum seal Maximum seal Maximum seal	Voltaje (V) Voltage (V) Voltage (V)	Euros
SB-600	60 cm	220	634,00
SB-1000	100 cm	220	907,00



**Soldadora de bolsas**

**Con regulador de temperatura, posición sobremesa.**

Bag sealer

With temperature regulator, positioning free standing.

*Scelleuse de sacs*

*Régulateur de température, position surtable.*

Ref.	Maximum seal Maximum seal Maximum seal	Voltaje (V) Voltage (V) Voltage (V)	Euros
SB-400-ECO	40 cm	220	144,00
SB-500-ECO	50 cm	220	255,00



**Soldador semiautomático con pedal**  
**Pedal eléctrico, ancho sellado de 5 mm.**

Semi-automatic sealer with pedal  
 Electric pedal, seal wide a 5 mm.

*Scelleuse semi automatique avec pédale*  
*Pédale électrique, largeur scellée 5 mm.*

Ref.	Medidas Size Dimensions	Maximum seal Maximum seal Maximum seal	Voltaje (V) Voltage (V) Voltage (V)	Euros
SBPA-450	53,5 x 38 x 88 cm	45 cm	220	1250,00
SBPA-600	68 x 38 x 88 cm	60 cm	220	1628,00

**MÁQUINA SELLAR | SEALER MACHINE | MACHINE À SCELLER**



**Máquina selladora en "U"**  
**Regulador de temperatura, acero-inox - epoxi blanco, posición sobre mesa.**

U- sealer machine  
 Temperature regulator, stainless steel, positioning free standing.

*Machine à sceller en forme de U*  
*Régulateur de température, acier inox époxy blanc, pose sur table.*

Ref.	Medidas Size Dimensions	Voltaje (V) Voltage (V) Voltage (V)	Euros
MR-15	35 x 33 x 35 cm	220	510,00



**Soldadora de bolsas magnético**  
**Soporte pared opcional. Especial para entrada hipermercados.**  
**Barra de soldadura de 50 cm.**

Magnetic bag sealer  
 Optional wall bracket. Special for supermarkets entrance. Welding rod 50 cm.

*Scelleuse de sacs magnétique*  
*Support mural optionnel. Spécial pour l'entrée des hypermarchés.*  
*Baguette de soudure 50 cm.*

Ref.	Voltaje (V) Voltage (V) Voltage (V)	Maximum seal Maximum seal Maximum seal	Euros
SBM-500	220 V	500 mm	928,00

**Mesa de trabajo colgada a la pared**

Work table hanging on the wall

*Table de travail suspendue au mur*

Ref.	Euros
SBM-505	361,00



**Máquina envasadora al vacío  
Estructura + cuba en acero inox.**

**6 programas memoria, con pantalla digital**

Vacuum packaging machine  
Stainless steel structure + cuba.

Memory 6 programs, with digital display

*Machine d'emballage sous vide  
Estructura + Cuba en acier inoxydable.*

*Mémoire 6 programmes, avec affichage numérique*

Ref.	Dimensiones máquina Machine size Dimensions machine	Dimensiones cámara Chamber size Dimensions chambre	Soldadura Seal Soudure	Peso Weight Poids	Bomba vacío Vacuum pump Pompe à vide	Voltaje (V) Voltage (V) Voltage (V)	Euros
<b>MV-10</b>	410 x 460 x 460 mm	310 x 350 x 190 mm	300 mm x 5 mm	38 kg	10 M3/h	230V / 50hz	<b>2690,00</b>
<b>MV-16</b>	510 x 560 x 480 mm	410 x 450 x 220 mm	400 mm x 5mm	48 kg	25 M3/h	230V / 50hz	<b>3080,00</b>
<b>MV-21</b>	610 x 630 x 500 mm	520 x 520 x 200 mm	500 mm x 5 mm	60 kg	25 M3/h	230V / 50hz	<b>3894,00</b>



**Máquina envasadora al vacío sin cámara  
Estructura acero-inox. Bolsa gofrada.**

Vacuum packaging machine without chamber  
Stainless steel body. Embossed bag.

*Machine d'emballage sous vide sans chambre  
Structure en acier inox. Sac gaufré.*

Ref.	Medidas Size Dimensions	Barra soldadura Seal bar Barre soudure	Bomba vacío Vacuum pump Pompe à vide	Peso Weight Poids	Voltaje (V) Voltage (V) Voltage (V)	Euros
<b>MVS-430</b>	490 x 295 x 180 mm	430 mm x 4 mm	28 L/min.	10 kg	220V / 50hz 95W	<b>788,00</b>



**Máquina envasadora al vacío sin cámara**  
**Estructura de ABS. Bolsa gofrada.**

Vacuum packaging machine without chamber  
ABS body. Embossed bag.

*Machine d'emballage sous vide sans chambre*  
*Structure en ABS. Sac gaufré.*

Ref.	Medidas Size Dimensions	Barra soldadura Seal bar Barre soudure	Bomba vacío Vacuum pump Pompe à vide	Voltaje (V) Voltage (V) Voltage (V)	Euros
MVS-330	38 x 18 x 11 cm	330 mm	16 Lt/min.	220V	245,00



**Máquina envasadora al vacío**  
**Estructura de ABS y PVC**

Vacuum packaging machine  
ABS and PVC structure

*Machine d'emballage sous vide*  
*Structure en ABS et PVC*

Ref.	Medidas Size Dimensions	Barra soldadura Seal bar Barre soudure	Bomba vacío Vacuum pump Pompe à vide	Peso Weight Poids	Voltaje (V) Voltage (V) Voltage (V)	Euros
MVS-100	35,7 x 14,8 x 7,3 cm	300 mm	10 Lt/min.	1,5 kg	220V	145,00

**PARRILLA ENVASADORA | PACKAGING GRILL | GRILL À EMBALLER**



**Parrilla envasadora para bolsa vacío**  
**Base polietileno. Varillas acero inox. Pomo giratorio**

Packing grill for vacuum bags  
Polyethylene base. Stainless steel rods. Rotating knob

*Grill à emballer pour sacs sous vide*  
*Base polyéthylène. Tiges acier inox. Pommeau giratoire*

Ref.	Medidas Size Dimensions	Euros
A-75	18,5 x 27 cm	99,00



**Pala envasadora para bolsa vacío**  
**Base polietileno.**

Packing grill for vacuum bags  
 Polyethylene base.

*Grill à emballer pour sacs sous vide*  
*Base polyéthylène.*

Ref.	Medidas Size Dimensions	Euros
A-76	38 x 18 cm	12,50
A-77	34 x 15 cm	11,50

**BOLSAS VACIO | VACUUM BAGS | SACS SOUS VIDE**



**Bolsa vacío gofrada**

Economic embossed vacuum bag

*Sac sous vide gaufré économique*

Ref.	Medidas Size Dimensions	Unidades Units Unités	Euros
BVX-1525	15 x 25 cm	100	11,50
BVX-1535	15 x 35 cm	100	16,00
BVX-1545	15 x 45 cm	100	21,00
BVX-2020	20 x 20 cm	100	12,50
BVX-2030	20 x 30 cm	100	18,50
BVX-2040	20 x 40 cm	100	24,50
BVX-2535	25 x 35 cm	100	27,00
BVX-3040	30 x 40 cm	100	36,50
BVX-3050	30 x 50 cm	100	45,50



**Rollo gofrado 20 x 600**

Embossed roller 20 x 600

*Rouleau gaufré 20 x 600*

Ref.	Medidas Size Dimensions	Unidades Units Unités	Euros
BVX-R20	20 x 600 cm	2	14,50

**Bolsa vacío gofrada cocción**

Embossed vacuum bag boiling

*Sac sous vide gaufré cuisson*

Ref.	Medidas Size Dimensions	Unidades Units Unités	Euros
BVXC-200300	20 x 30 cm	100	35,00



**Bolsa vacío M8 COEX**

M 8COEX vacuum bags

Sacs sous vide M8 COEX

Ref.	Medidas Size Dimensions	Unidades Units Unités	Euros
BV-140450	14 x 45 cm	1200	140,00
BV-150200	15 x 20 cm	1500	84,00
BV-150250	15 x 25 cm	1500	104,00
BV-175250	17,5 x 25 cm	1200	98,50
BV-180300	18 x 30 cm	1000	100,00
BV-200200	20 x 20 cm	1000	74,50
BV-200250	20 x 25 cm	1000	93,00
BV-200300	20 x 30 cm	1000	111,00
BV-200350	20 x 35 cm	1000	131,00
BV-200400	20 x 40 cm	1000	149,00
BV-250350	25 x 35 cm	1000	162,00
BV-300400	30 x 40 cm	1000	222,00
BV-350500	35 x 50 cm	500	162,00
BV-350600	35 x 60 cm	500	195,00
BV-400500	40 x 50 cm	500	185,00
BV-400600	40 x 60 cm	500	222,00



**Bolsas vacío plata y oro "PRODUCTO DE CALIDAD"**

Gold vacuum bags

Sacs sous vide d'or

Ref.	Medidas Size Dimensions	Tipo Type Type	Unidades Units Unités	Euros
BVPO-200300	20 x 30 cm	Oro	1200	276,00
BVPP-200300	20 x 30 cm	Plata	1200	265,00

**Bolsa vacío M15 COEX**

M15 COEX vacuum bags

Sacs sous vide M15 COEX

Ref.	Medidas Size Dimensions	Unidades Units Unités	Euros
BVE-200300	20 x 30 cm	500	106,00
BVE-250350	25 x 35 cm	500	154,00
BVE-300400	30 x 40 cm	500	211,00
BVE-350450	35 x 45 cm	300	165,00
BVE-350600	35 x 60 cm	300	220,00



**Bolsas vacío plata-transparente**

Transparent-silver vacuum bags

Sacs sous vide argent transparent

Ref.	Medidas Size Dimensions	Unidades Units Unités	Euros
BVP-175250	17,5 x 25 cm	1000	126,00
BVP-175300	17,5 x 30 cm	1000	150,00
BVP-200250	20 x 25 cm	1000	143,00
BVP-200300	20 x 30 cm	1000	169,00

**Bolsa vacío cocción a 121° C**

Vacuum bag boiled at 121° C

Sacs sous vide cuisson à 121° C

Ref.	Medidas Size Dimensions	Unidades Units Unités	Euros
BVC-150200	15 x 20 cm	1000	97,00
BVC-185250	18,5 x 25 cm	1000	150,00
BVC-200300	20 x 30 cm	500	97,00
BVC-250350	25 x 35 cm	500	142,00
BVC-300400	30 x 40 cm	500	194,00
BVC-350500	35 x 50 cm	500	315,00



**Bolsa asado con asa para microondas  
Troquel zipper**

Roasted microwave bag with handle  
Troquel zipper

Sac rôti avec poignée micro-ondes  
Fermeture éclair découpée

Ref.	Medidas Size Dimensions	Unidades Units Unités	Euros
BVA-1	30,5 x 25 + 7,5 cm	500	173,00
BVA-2	35 x 29 + 7,5 cm	500	203,00
BVA-3	35 x 29 + 10 cm	500	211,00



**Bolsa de pescado con asa  
Troquel zipper**

Fish bag with handle  
Troquel zipper

Sac à poisson avec poignée  
Fermeture éclair découpée

Ref.	Medidas Size Dimensions	Unidades Units Unités	Euros
BVA-4	30 x 25 + 5 cm	500	229,00



Nota: **Fabricamos bolsas a medida**



**Termoselladora de barquetas 400 W**  
**Incluye molde 95 x 135 y 135 x 195**

Tray packaging thermo sealer 400 W  
 Includes mold 95 x 135 and 135 x 195

*Thermo machine à sceller de barquettes 400 W*  
*Comprend moules 95 x 135 et 135 x 195*

Ref.	Medidas Size Dimensions	Voltaje (V) Voltage (V) Voltage (V)	Euros
MT-152	18,7 x 40 cm	230	1180,00



**Termoselladora de barquetas 600 W 1/4 GASTRONORM**

Tray packaging thermo sealer 600 W GASTRONORM

*Thermo machine à sceller de barquettes 600 W GASTRONORM*

Ref.	Medidas Size Dimensions	Voltaje (V) Voltage (V) Voltage (V)	Euros
MT-192	22,8 x 49 cm	230	1616,00





**Termoselladora de barquetas 1200 W 1/2 GASTRONORM**

Tray packaging thermo sealer 1200 W GASTRONORM

Thermo machine à sceller de barquettes 1200 W GASTRONORM

Ref.	Medidas Size Dimensions	Voltaje (V) Voltage (V) Voltage (V)	Euros
MT-270	34,5 x 53,5 mm	230	2525,00



**Molde medidas GN-1/4 barquetas para MT-192**

Mold sizes  
GN-1/4 tray for MT-192

Moule mesures  
GN-1/4 Barquettes for MT-192

Ref.	Medidas Size Dimensions	Euros
MTM-1/4	26,4 x 16,2 cm	298,00

**Molde medidas GN-1/2 barquetas para MT-270**

Mold sizes  
GN-1/2 tray for MT-270

Moule mesures  
GN-1/2 Barquettes for MT-270

Ref.	Medidas Size Dimensions	Euros
MTM-1/2	32,5 x 26,5 cm	375,00

**Bobina film termosellar**

Termo packaging film roll

Boines film termo-sceller

Ref.	Medidas Size Dimensions	Euros
MTB-15	15 x 300 cm	24,00
MTB-20	20 x 300 cm	33,00
MTB-27	27 x 300 cm	44,00



0

5

**Secamanos, Dispensadores papel celulosa, Papel celulosa, Dosificadores jabón, Grifos - caño electrónico, Grifos ducha, Lavamanos, Portacuchillos - Papeleras, Esterilizadores de cuchillos, Contenedores plástico, Contenedores papeleras acero-inoxidable, Cañon de ozono.**

---

Hand dryer, Cellulose paper dispenser, Cellulose paper, Soap dispensers, Tap with electronic spout, Shower tap, Washbin, Knife holder - Waste baskets, Knives sterilizer, Plastic container, Stainless steel containers-bins, Ozone cannon.

---

*Sèche-mains, Dispensateur papier cellulose, Papier cellulose, Doseurs de savon, Robinet électronique, Robinet douche, Lave - mains, Porte couteaux - Poubelles, stérilisateur de couteaux, Conteneurs plastique, Conteneur-poubelle acier inox, Canon à ozone.*

**101 - 120**



**Secamanos alta velocidad**  
**Carcasa ABS blanco. Potencia 2050W. Velocidad 95 m/sg**

High speed hand dryer  
 White ABS frame. Power 2050W. Speed 95 m/sg.

*Sèche-mains à grande vitesse*  
*Carcasse ABS blanc. Puissance 2050W. Vitesse 95 m/sg.*

Ref.	Medidas Size Dimensions	Euros
SM-700	30 x 22 x 68,5 cm	856,00

SECAMANOS | HAND DRYER | SÈCHE MAINS



**Secamanos**  
**Control: célula de infrarrojos por proximidad. Caudal Aire : 225 m3/h. Interruptor aire: frío-caliente. Potencia 1650W**

Hand dryer  
 Control: Infra-red cell proximity control. Air-flow: 225 m3/h. Switch: cold or hot air. Power 1650W

*Sèche-mains*  
*Control: cellule infrarouges par proximité. Débit air: 225 m3/h. Interrupteur: air froid ou chaud. Puissance 1650W*



**Secamanos**  
**Control: célula de infrarrojos por proximidad. Caudal aire: 270 m3/h. Carcasa: acero satinado. Potencia 2500W**

Hand dryer  
 Infra-red cell proximity control. Air-flow: 270 m3/h. Frame: Satin finish steel. Power 2500W

*Sèche mains*  
*Contrôle: cellule infrarouges par proximité. Débit air: 270m3/h. Carcasse: acier satiné. Puissance 2500W*

Ref.	Medidas Size Dimensions	Voltaje (V) Voltage (V) Voltage (V)	Peso Weight Poids	Euros
SM-5	14 x 27 x 22 cm	220	2,4 kg	120,00

Ref.	Medidas Size Dimensions	Voltaje (V) Voltage (V) Voltage (V)	Peso Weight Poids	Euros
SM-6	20 x 26 x 21 cm	220	6,26 kg	289,00



**Portabobinas plegable suelo acero-inox**  
**Tipo de papel celulosa ref. PB-10**

Stainless steel foldable standing paper reel holder  
 Paper type : cellulose ref. PB-10

*Porte bobines pliant sol acier inox*  
*Type papier: cellulose réf. PB-10*

Ref.	Medidas Size Dimensions	Euros
PB-1	40 x 45 x 83 cm	37,00



**Portabobinas mural y sobremesa acero-inox**  
**Tipo de papel : celulosa ref. PB-10**

Stainless steel foldable standing paper reel holder  
 Paper type: cellulose ref. PB-10

*Porte bobines mural/dessus de table acier inox*  
*Type papier: cellulose réf. PB-10*

Ref.	Euros
PB-1-M	36,00



**Portarrollos higiénico inox**

Cellulose paper dispenser  
 Stainless steel hygienic paper roll holder

*Porte rouleaux hygiénique inox*

Ref.	Diámetro Diameter Diamètre	Largo Long Longueur	Euros
PB-2	Ø 25 cm	11,5 cm	45,00



**Portarrollos higiénico epoxi blanco**  
**Eje 4,5. Tipo de papel : celulosa ref. PB-30**

White epoxy hygienic paper roll holder  
 Axis 4,5 cm. Paper type : cellulose ref. PB-30

*Porte rouleaux hygiénique époxy blanc*  
*Axe 4,5 cm. Type papier : cellulose réf. PB-30*

Ref.	Diámetro Diameter Diamètre	Largo Long Longueur	Euros
PB-3	Ø 25 cm	11,5 cm	45,00



**Portarrollos higiénico WC**  
**Con visor.**

Hygienic paper roll holder  
 With visier.

*Porte rouleaux hygiénique*  
*Avec viseur.*

Ref.	Medidasz Size Dimensions	Color Colour Couleur	Euros
PB-21	32,5 x 30,5 x 13 cm	○	19,00
PB-21N	32,5 x 30,5 x 13 cm	●	29,00



**Dispensador de papel tipo mecha**  
**Tipo de papel : celulosa ref. PB-50**

Mecha paper dispenser  
Paper type : cellulose ref. PB-50

*Distributeur de papier de type mèche*  
*Type papier : cellulose réf. PB-50*

Ref.	Medidas Size Dimensions	Euros
PB-9	26,5 x 35 cm	39,00



**Dispensador papel tipo mecha**  
**Con visor.**

Mini mecha paper dispenser  
With viewer.

*Dispensateur de papier de type mèche*  
*Avec viseur*

Ref.	Medidas Size Dimensions	Color Colour Couleur	Euros
PB-24	32 x 21 x 22 cm	○	24,00
PB-24N	32 x 21 x 22 cm	●	35,00



**Dispensador papel tipo mecha**  
**Tipo papel: ref. PB-50**

Mecha paper dispenser

*Distributeur de papier de type mèche*  
*Type papier : cellulose ref. PB-50*

Ref.	Diámetro Diameter Diamètre	Altura Height Hauteur	Euros
PB-12	Ø 32 cm	25 cm	166,00

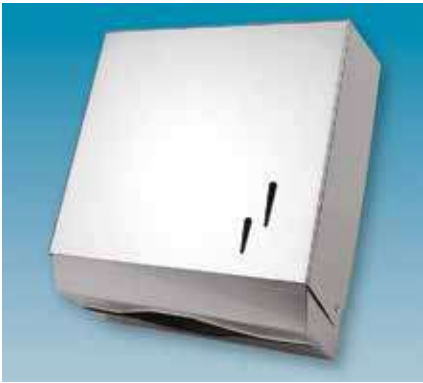

**Dispensador toallitas Z/Z acero inox**  
**Tipo de papel : ref. PB-70**

Z/Z folded towel dispenser  
Paper type : ref. PB-70

*Distributeur lingettes Z/Z*  
*Type papier: ref. PB-70*

Ref.	Medidas Size Dimensions	Euros
PB-8	33 x 26,5 x 12 cm	50,00



**Dispensador toallitas Z/Z epoxi blanco**  
**Tipo de papel : ref. PB-70**

Z/Z folded towel dispenser  
Paper type : ref. PB-70

*Distributeur lingettes Z/Z*  
*Type papier : ref. PB-70*

Ref.	Medidas Size Dimensions	Euros
PB-7	31 x 26,5 x 12 cm	52,00



**Dispensador toallitas Z/Z ABS**  
**Con visor.**

ZZ towels dispenser ABS  
With viewer.

*Dispensateur lingettes ZZ ABS*  
*Avec viseur.*

Ref.	Medidas Size Dimensions	Color Colour Couleur	Euros
PB-22	37 x 27,5 x 13,5 cm	○	19,00
PB-22N	37 x 27,5 x 13,5 cm	●	29,00



**Dispensador de papel tipo mecha mini**  
**Con visor**

Mini mecha paper dispenser  
With viewer

*Dispensateur de papier de type mèche mini*  
*Avec viseur*

Ref.	Medidas Size Dimensions	Color Colour Couleur	Euros
PB-23	14 x 16 x 29 cm	○	18,00
PB-23N	14 x 16 x 29 cm	●	24,00



**Dispensador de papel tipo mecha mini**  
**Tipo de papel : celulosa ref. PB-40**

Mini mecha paper dispenser  
 Paper type : cellulose ref. PB-40

*Distributeur de papier de type mèche*  
*Type papier : cellulose réf. PB-40*

Ref.	Medidas Size Dimensions	Euros
PB-11	15 x 27 cm	33,00

PAPEL CELULOSA | CELLULOSE PAPER | PAPIER CELLULOSE



**Bobina mecha 2 capas**

Roll of 2-layer cellulose paper

*Bobine cellulose 2 épaisseurs*

Ref.	Largo Long Longueur	Unidades Units Unités	Euros
PB-40	65 m	12	35,50
PB-50	180 m	6	47,50

**Bobina celulosa industrial 2 capas**

Roll of 2-layer industrial paper

*Rouleau cellulose industrielle 2 épaisseurs*

Ref.	Largo Long Longueur	Unidades Units Unités	Euros
PB-10	500 m	2	51,50

**Rollo papel higiénico dos capas**

Reel of 2-layer hygienic paper

*Bobine cellulose hygiénique 2 épaisseursZ*

Ref.	Largo Long Longueur	Unidades Units Unités	Euros
PB-30	150 m	18	50,00

**Totallitas Z/Z**  
**200 uds x 20 paquetes**

Z/Z folded towel  
 200 units x 20 packs

*Lingettes Z/Z*  
*200 units x 20 paquet*

Ref.	Euros
PB-70	38,50



**Dosificador de jabón luxe**

Deluxe soap dispensers

*Doseur de savon luxe*

Ref.	Medidas Size Dimensions	Capacidad Capacity Capacité	Euros
D-1	12 x 11 cm	1 l	22,00



**Dosificador de jabón**

Soap dispenser

*Doseur de savon*

Ref.	Diámetro Diameter Diamètre	Altura Height Hauteur	Capacidad Capacity Capacité	Euros
D-2	Ø 13 cm	24 cm	2 l	33,00



**Dosificador de jabón  
Color blanco**

Soap dispenser  
White colour

*Doseur de savon  
Couleur blanc*

Ref.	Medidas Size Dimensions	Capacidad Capacity Capacité	Euros
D-4-B	9 x 10 x 22,5 cm	1 l	24,50



**Dosificador jabón cromado**

Soap dispenser chrome

*Doseur de savon chromé*

Ref.	Medidas Size Dimensions	Capacidad Capacity Capacité	Euros
D-4-C	9 x 10 x 22,5 cm	1 l	37,50



**Dosificador jabón  
Color blanco o negro. Con visor**

Soap dispenser  
White or black colour. With viewer

*Doseur de savon  
Couleur blanc ou noir. Avec viseur*

Ref.	Medidas Size Dimensions	Capacidad Capacity Capacité	Euros
D-7	13 x 9,5 x 21,5 cm	0,8 l	16,00
D-7-N	13 x 9,5 x 21,5 cm	0,8 l	20,00



**Dosificador jabón**

Soap dispenser

*Doseur de savon*

Ref.	Medidas Size Dimensions	Capacidad Capacity Capacité	Euros
D-8	11,6 x 5,8 x 17,5 cm	0,8 l	45,00





**Dosificador de jabón electrónico  
Color blanco**

Electronic soap dispenser  
White colour

*Doseur de savon  
Couleur blanc*

Ref.	Medidas Size Dimensions	Capacidad Capacity Capacité	Euros
D-11	14 x 11,8 x 23,4 cm	1 l	48,00



**Dosificador de gel electrónico  
Color blanco**

Electronic gel dispenser  
White colour

*Doseur de gel  
Couleur blanc*

Ref.	Medidas Size Dimensions	Capacidad Capacity Capacité	Euros
D-12	13 x 12 x 27 cm	0,9 l	46,00

**GRIFO-CAÑO ELECTRÓNICO | TAP WITH ELECTRONIC SPOUT | ROBINET ÉLECTRONIQUE**



**SopORTE metálico negro con dosificador electrónico de gel y papelera de plástico con pedal negro.**

Black metal support with electronic dispenser gel and plastic bin with black pedal.

*Support en métal noir avec distributeur électronique bac à gel et plastique à pédale noire.*

Ref.	Medidas Size Dimensions	Euros
D-50	30 x 30 x 130 cm	155,00



**Grifo con kit electrónico  
Sensor infrarrojo.**

Tap with electronic kit  
Infrared sensor.

*Robinet avec kit électronique  
Senseur infrarouge.*

Ref.	Voltaje (V) Voltage (V) Voltage (V)	Tensión de trabajo (V) Working voltage (V) Tension de travail (V)	Euros
LM-10	220	12	264,00

**Grifo con kit electrónico pilas  
Grifo un agua. Sensor infrarrojo. 4 pilas AA de 1,5V**

Tap with battery powered electronic kit  
Single water tap. Infrared sensor. Four 1,5V AA batteries.

*Robinet avec kit électronique à piles  
Robinet 1 eau. Senseur infrarouge. 4 piles AA de 1,5V*

Ref.	Tensión de trabajo (V) Working voltage (V) Tension de travail (V)	Euros
LM-10-P	6	281,00





**Caño giratorio eco**

Eco swivel spout

*Bec giratoire éco*

Ref.	Euros
LM-1-2	27,50

**Válvula mezcladora 2 aguas**

Double water mixer valve

*Valve mélangeuse 2 eaux*

Ref.	Euros
LM-11	27,50

**Caño giratorio**

Swivel spout

*Bec giratoire*

Ref.	Euros
LM-1-3	53,00

**Pedal 1 agua**

Single water pedal

*Pédale 1 eau*

Ref.	Euros
LM-2-1	57,00

**Pedal 2 aguas**

Double water pedal

*Pédale 2 eaux*

Ref.	Euros
LM-2-2	97,00

**Pulsador temporizador**

Press button timer

*Bouton poussoir minuterie*

Ref.	Euros
LM-1-1	40,00



**Grifo ducha extensible de un agua.  
Piña blanca.**

Single extendable shower tap.  
White shower head

*Robinet dluche extensible une eau.  
Pomme blanche.*

Ref.	Euros
LM-21	224,00



**Grifo ducha extensible de dos aguas.  
Piña blanca.**

Double extendable shower tap.  
White shower head

*Robinet douche extensible deux eaux.  
Pomme blanche.*

Ref.	Euros
LM-22	244,00



**Grifo ducha extensible de un agua  
Piña negra**

Single extendable shower tap  
White shower head

*Robinet douche extensible une eau  
Pomme noire.*

Ref.	Euros
LM-23	234,00



**Mural dos aguas**

Double water wall tap

*Robinet mural deux eaux*

Ref.	Euros
LM-26	68,00

**Grifo ducha extensible de dos aguas  
Piña negra**

Double extendable shower tap  
White shower head

*Robinet douche extensible deux eaux.  
Pomme noire*

Ref.	Euros
LM-24	248,00



**Caño giratorio con monomando codo  
Acoplable para grifos ducheta**

Single lever mixer wall tap with swivel spout

Robinet mural à bec giratoire mitigeur

Ref.	Euros
LM-27	224,00

**Flexo ducheta, 120 cm**

Hose, 120 cm

Tuyau, 120 cm

Ref.	Para For Pour	Euros
LM-21-2	LM-21, LM-22	27,00

**Flexo ducheta, 120 cm, transparente**

Hose, 120 cm, transparent

Tuyau, 120 cm, transparent

Ref.	Para For Pour	Euros
LM-23-2	LM-23, LM-24	27,00

**SopORTE pared y piña**

Wall holder and head shower

Support de mur et robinet de douche

Ref.	Para For Pour	Euros
LM-21-3	LM-21, LM-22, LM-23, LM-24	37,00

**Muelle para flexo ducha**

Spring for hose

Ressort pour tuyau

Ref.	Para For Pour	Euros
LM-21-4	LM-21, LM-22, LM-23, LM-24	39,00





**Piña ducheta para ref. LM-21 y LM-22**

Shower head adaptable to ref. LM-21 and LM-22

*Pomme de douche pour ref. LM-21 et LM-22*

Ref.	Euros
LM-21-1	86,00

**Piña ducheta para ref. L-23 y LM-24**

Shower head for ref. LM-23 and LM-24

*Pomme de douche pour réf. LM-23 et LM-24*

Ref.	Euros
LM-23-1	88,00

**Caño giratorio acoplable para grifos ducha.**

Revolving spout can be fitted to shower taps

*Bec giratoire adaptable pour robinets douche*

Ref.	Euros
LM-25	88,00

**LAVAMANOS | WASHBASIN | LAVE-MAINS**



**Lavamanos inox con pulsador de pie Mezclador agua fría y caliente. Caño giratorio. Alto mas 30 cm de PETO**

Stainless steel washbasin with foot operated push button  
Cold and hot warer mixer. Swivel spout.

*Lave-mains inox avec bouton-poussoir actionné par le pied  
Mélangeur eau froide et chaude. Bec giratoire.*

Ref.	Medidas Size Dimensions	Euros
LM-1	45 x 45 x 86 cm	448,00



**Lavamanos inox con pedal  
Mezclador agua fría y caliente. Caño fijo.**

Stainless steel washbasin with pedal  
Cold and hot water mixer. Fixed spout.

*Lave-mains inox avec pédale  
Mélangeur eau froid et chaude. Bec fixe.*

Ref.	Medidas Size Dimensions	Euros
LM-2	45 x 45 x 85 cm	499,00

**Lavamanos inox con 2 pedales  
Mezclador agua fría y caliente.**

Stainless steel washbasin with 2 pedals  
Cold and hot water mixer.

*Lave-mains inox. avec 2 pédale  
Mélangeur eau froide et chaude*

Ref.	Medidas Size Dimensions	Euros
LM-2-P	45 x 45 x 85 cm	543,00



**Lavamanos inox mural  
Con mezclador. Pulsador de rodilla. Caño giratorio**

Wall stainless steel washbasin  
With mixer. Knee push button. Swivel spout.

*Lave-mains inox mural  
Avec mixeur. Bouton poussoir genou. Bec giratoire.*

Ref.	Medidas Size Dimensions	Euros
LM-4	35 x 30 x 21,5 cm	254,00

**Peto para ref. LM-4**

Guard for ref. LM-4

*Plastron pour réf. LM-4*

Ref.	Euros
LMP-4	38,00



**Lavamanos inox mural  
Pulsador de rodilla. Mezclador agua fría y caliente. Caño fijo.**

Wall stainless steel washbasin  
Knee push button. Cold and hot water  
mixer. Fixed spout.

*Lave-mains inox mural avec mélangeur  
Bouton poussoir genou. Mélangeur eau  
froide et chaude. Bec fixe.*

Ref.	Medidas Size Dimensions	Euros
LM-5	45 x 45 x 21,5 cm	317,00

**Peto para ref. LM-2, LM-5**

Guard for ref. LM-2, LM-5

*Plastron pour réf. LM-2, LM-5*

Ref.	Euros
LMP-5	38,00



**Papelera rejilla, acero-inox**

Grille waste paper basket, stainless steel

Poubelle rejilla, acier-inox

Ref.	Medidas Size Dimensions	Euros
A-95	60 x 7,5 x 22 cm	44,00



**Portacuchillos protegido, acero-inox  
Con tres ranuras para cuchillos y chaira  
ovalada-redonda**

Encased knife holder, stainless steel  
Three grooves for knives and oval  
professional sharpener

Porte couteaux et fusil ovale rond, acier inox  
Avec trois rainures pour couteaux et fusil  
ovale rond

**Papelera, acero inox**

Waste paper bin, stainless steel

Poubelle, acier inox

Ref.	Medidas Size Dimensions	Euros	Ref.	Medidas Size Dimensions	Euros
EC-10	38 x 9 x 38 cm	120,00	A-90	33 x 13 x 27,5 cm	70,00



**Esterilizador de cuchillos por ozono  
Acero-inox, Duración aconsejable 15 minutos**

Ozone Knife steriliser  
Stainless steel, Recommended time 15 minutes

Stérilisateur de couteaux par ozone  
Acier inox, recommandé 15 minutes

Ref.	Medidas Size Dimensions	Voltaje (V) Voltage (V) Voltage (V)	Euros
EC-1	60 x 10 x 35 cm	220 V	420,00



**Cañon de ozono 10 G/H con temporizador.  
Producción 10 gramos hora.**

Ozone cannon 10 G/H with timer.  
Production 10 grams per hour.

Canon à ozone 10 G/H avec minuterie.  
Production 10 grammes par heure.

Ref.	Medidas Size Dimensions	Voltaje (V) Voltage (V) Voltage (V)	Euros
OZ-10G	23 x 18 x 17 cm	220 V	175,00



**Esterilizador de cuchillos por agua caliente**  
**De acero-inox, resistencia de 750 W estanco y una temperatura aconsejable de 82°.**

Hot water knife steriliser  
 Stainless steel, resistance a 750 W watertight and a recommended temperature of 82°.

*Stérilisateur de couteaux par eau chaude*  
*Acier inox, résistance 750 W étanche, température recommandée 82°.*

Ref.	Medidas Size Dimensions	Voltaje (V) Voltage (V) Voltage (V)	Euros
EC-5-45	35 x 10 x 45 cm	220	724,00

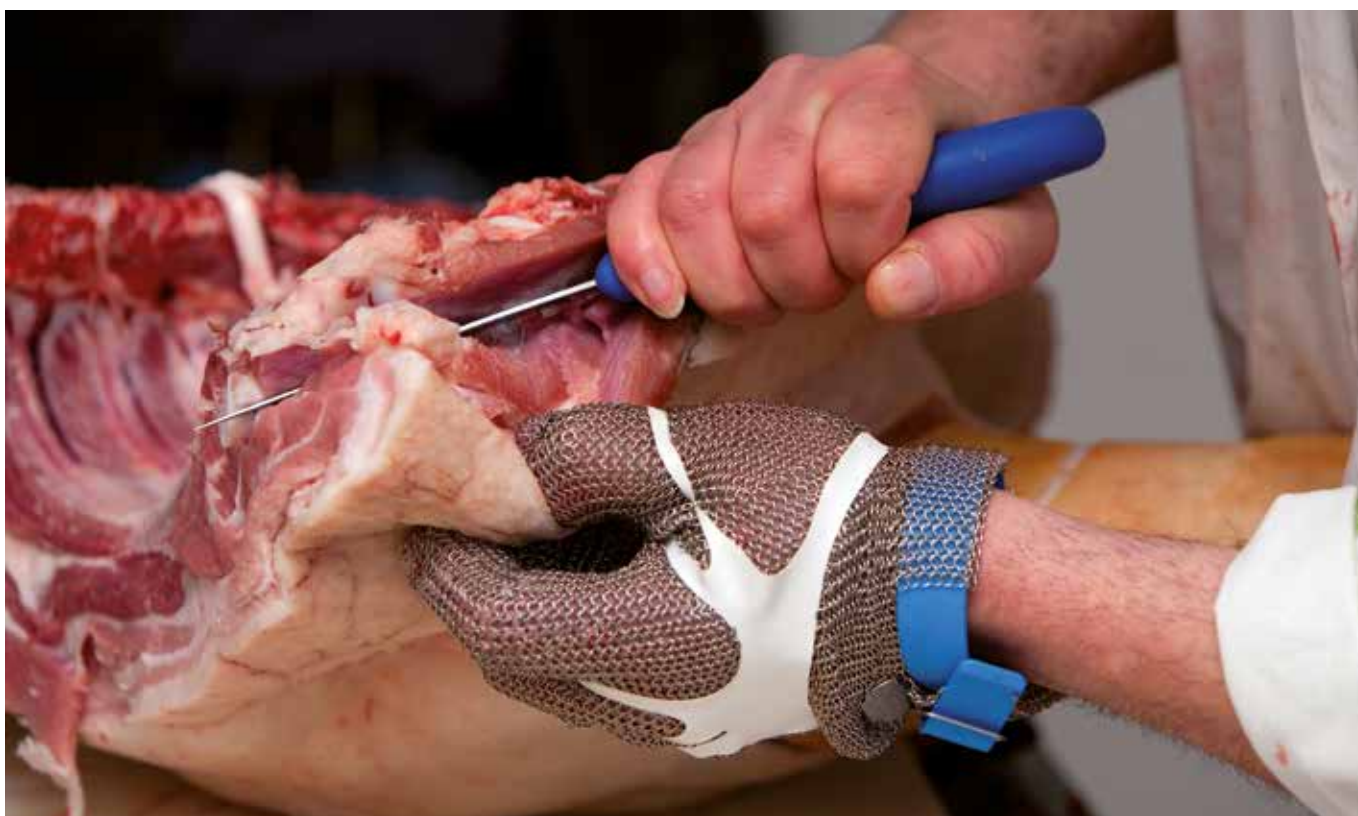





**Armario esterilizador por lámpara de ozono  
2 barras de imán. Puerta de metacrilato transparente para poder acceder totalmente a su interior, acero inox**

Ozone lamp steriliser cabinet  
Two-bar magnet. Transparent methacrylate door for easy access, stainless steel.

*Armoire stérilisation par lampe d'ozone  
2 barre aimant. Porte en méthacrylate transparent pour pouvoir accéder complètement à l'intérieur, acier inox.*

Ref.	Medidas Size Dimensions	Voltaje (V) Voltage (V) Voltage (V)	Euros
EC-35	35 x 58 x 12 cm	220	606,00

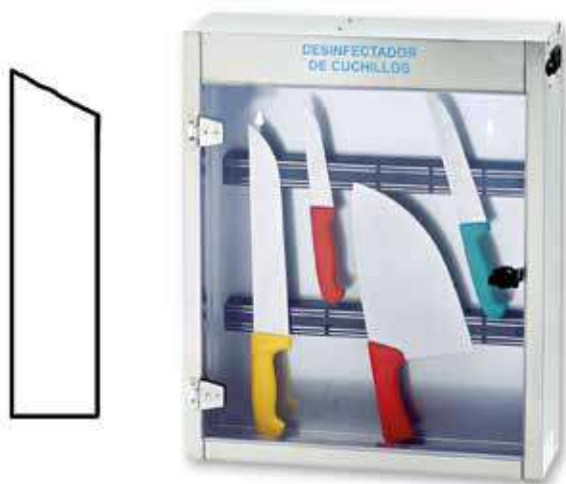

**Armario esterilizador por lámpara de ozono  
2 barras de imán. Puerta de metacrilato para poder acceder totalmente a su interior, acero-inox.**

**Techo inclinado**

Ozone lamp steriliser cabinet  
Two-bar magnet. Transparent methacrylate door for easy access, stainless steel.

Sloping top

*Armoire stérilisation par lampe d'ozone  
2 barre aimant. Porte en méthacrylate transparent pour pouvoir accéder complètement à l'intérieur, acier-inox.*

*Toit incliné*

Ref.	Medidas Size Dimensions	Voltaje (V) Voltage (V) Voltage (V)	Euros
EC-55	47 x 58 x 12 cm	220	715,00



**Armario esterilizador por lámpara de ozono  
4 barras de imán. Puerta de metacrilato transparente para poder acceder totalmente a su interior, acero inox.**

**Techo inclinado**

Ozone lamp steriliser cabinet  
4-bar magnet. 2 transparent methacrylate door for easy access, stainless steel.

Sloping top

*Armoire stérilisation par lampe d'ozone  
4 barre aimant. 2 porte en méthacrylate transparent pou pouvoir accéder complètement à l'intérieur, acier-inox*

*Toit incliné*

Ref.	Medidas Size Dimensions	Voltaje (V) Voltage (V) Voltage (V)	Euros
EC-105	100 x 59 x 12 cm	220	1128,00



**Armario esterilizador ultravioleta**  
**Soporte: inox 10 cuchillos. Puerta: plexiglas transparente ahumado. Lámpara: UVC 15W. Temporizador: reloj 0 a 2 horas. Duración aconsejada 1h 30. Acero-inox.**

UV steriliser cabinet  
 Stand: stainless steel 10 knives. Door: transparent smoked Plexiglas.  
 Lamp: UVC 15W. Timer: 0 to 2 hrs clock. Recommended duration: 1h 30. Stainless steel.

*Armoire stérilisatrice ultraviolette*  
*Support: inox 10 couteaux. Porte: plexiglas transparent teinté.*  
*Lampe: UVC 15W. Minuterie: horloge 0 à 2h. Durée recommandée: 1h 30. Acier-inox*

Ref.	Medidas Size Dimensions	Voltaje (V) Voltage (V) Voltage (V)	Euros
ECU-25	35 x 12,5 x 57,5 cm	220	361,00



**Armario esterilizador ultravioleta**  
**Soporte: inox 20 cuchillos. Puerta: plexiglas transparente ahumado. Lámpara: UVC 15W. Temporizador: reloj 0 a 2h. Duración aconsejada: 1h 30. Acero-inox.**

UV steriliser cabinet  
 Stand: stainless steel 20 knives. Door: transparent smoked plexiglas.  
 Lamp: UVC 15W. Timer: 0 to 2 h clock. Recommended duration: 1h 30. Stainless steel.

*Armoire stérilisatrice ultraviolette*  
*Support: inox 20 couteaux. Porte: plexiglas transparent teinté.*  
*Lampe: UVC 15W. Minuterie : horloge 0 à 2h. Durée recommandée 1h 30. Acier Inox.*

Ref.	Medidas Size Dimensions	Voltaje (V) Voltage (V) Voltage (V)	Euros
ECU-50	44 x 12,5 x 57,5 cm	220	396,00



**Armario esterilizador ultravioleta**  
**Soporte: inox 30 cuchillos. Puerta: plexiglas transparente ahumado. Lámpara 2x15W. Temporizador: reloj 0 a 2 horas. Duración aconsejada: 1h 30. Acero-inox.**

UV steriliser cabinet  
 Stand: stainless steel 30 knives. Door: transparent smoked plexiglas.  
 Lamp: 2x15W. Timer: 0 to 2 h clock. Recommended duration: 1h 30. Stainless steel.

*Armoire stérilisatrice ultraviolette*  
*Support: inox 30 couteaux. Porte: plexiglas transparent teinté.*  
*Lampe: 2x15W. Minuterie: horloge 0 à 2h. Durée recommandée: 1h 30. Acier inox.*

Ref.	Medidas Size Dimensions	Voltaje (V) Voltage (V) Voltage (V)	Euros
ECU-100	75 x 12,5 x 57,5 cm	220	700,00



**Carro contenedor de basura  
Tapa abatible con pedal.**

Two-wheel mobile garbage bin  
Pedal lift-top

*Chariot conteneur de déchets  
Couvercle rabattable avec pédale.*

Ref.	Medidas Size Dimensions	Capacidad Capacity Capacité	Color Colour Couleur	Euros
W-60	50,5 x 44,5 x 70 cm	60 l	○ ● ●	122,00



**Carro contenedor de basura  
Tapa abatible con pedal.**

Two-wheel mobile garbage bin  
Pedal lift top.

*Chariot conteneur de déchets  
Couvercle rabattable avec pédale.*

Ref.	Medidas Size Dimensions	Capacidad Capacity Capacité	Color Colour Couleur	Euros
W-80	50,5 x 44,5 x 84,5 cm	80 l	● ●	127,00



**Carro contenedor de basura  
Tapa abatible con pedal.**

Two-wheel mobile garbage bin  
Pedal-lift top.

*Chariot conteneur de déchets  
Couvercle rabattable avec pédale.*



Ref.	Medidas Size Dimensions	Capacidad Capacity Capacité	Color Colour Couleur	Euros
W-120	55 x 58 x 93 cm	120	○ ● ● ● ● ● ● ●	127,00



**Carro contenedor de basura  
Tapa abatible con pedal.**

Two-wheel mobile garbage bin  
Pedal-lift top.

*Chariot conteneur de déchets  
Couvercle rabattable avec pédale.*

Ref.	Medidas Size Dimensions	Capacidad Capacity Capacité	Color Colour Couleur	Euros
W-240	74 x 58 x 107 cm	240 l	● ●	169,00



**Cubo de basura con pedal  
Con aro sujeta bolsas. 28 l**

Pedal bin  
With hoop holds bags. 28 l

*Poubelle à pédale  
Avec cerceau détient des sacs. 28 l*

Ref.	Medidas Size Dimensions	Color Colour Couleur	Euros
W-28	33 x 35 x 49,5 cm	○	34,00



**Carro contenedor de basura  
Tapa abatible con pedal.**

Two-wheel mobile garbage bin  
Pedal lift top.

*Chariot conteneur de déchets  
Couvercle rabattable avec pédale.*

Ref.	Medidas Size Dimensions	Capacidad Capacity Capacité	Color Colour Couleur	Euros
W-81	55 x 58 x 93 cm	80 l	○	95,00

**CONTENEDORES - PAPELERAS ACERO-INOXIDABLE | BINS - STAINLESS STEEL CONTAINERS-BINS | CONTENEUR-POUBELLE ACIER INOX**



**Papelera basculante acero-inox  
Tapa basculante. Parte superior extraíble**

Stainless steel container  
Lift-top. Removable upper part

*Conteneur acier inox  
Couvercle basculant. Partie supérieure amovible*

Ref.	Medidas Size Dimensions	Capacidad Capacity Capacité	Euros
WI-35	30 x 20 x 70 cm	35 l	275,00



**Papelera basculante acero-inox**  
**Tapa basculante. Parte superior extraible**

Stainless steel container  
Lift-top. Removable upper part

*Conteneur acier inox*  
*Couvercle basculant. Partie supérieure amovible*

Ref.	Medidas Size Dimensions	Capacidad Capacity Capacité	Euros
WI-75	40 x 30 x 90 cm	75 l	303,00



**Contenedor acero-inox**  
**Tapa con pedal. Puerta frontal para extraer bolsa. Asa H72**

Stainless steel container  
Pedal-lift top. Frontal door for bag removal. Handle H 72

*Conteneur acier inox*  
*Couvercle avec pédale. Porte avant pour extraire le sac. Asa H 72*

Ref.	Medidas Size Dimensions	Capacidad Capacity Capacité	Euros
WI-70	46 x 36 x 72 cm	70 l	416,00



**Contenedor acero-inox**  
**Tapa con pedal. Puerta frontal para extraer bolsa. Asa H92**

Stainless steel container  
Pedal-lift top. Frontal door for bag removal. Handle H 92

*Conteneur acier inox*  
*Couvercle avec pédale. Porte avant pour extraire le sac. Asa H 92*

Ref.	Medidas Size Dimensions	Capacidad Capacity Capacité	Euros
WI-90	46 x 36 x 92 cm	90 l	478,00



**Contenedor acero-inox**  
**Tapa con pedal**

Stainless steel container  
Pedal-lift top

*Conteneur acier inox*  
*Couvercle avec pedale*

Ref.	Díámetro Diameter Diamètre	Altura Height Hauteur	Capacidad Capacity Capacité	Euros
WI-110	Ø 40 cm	86 cm	110 l	306,00



**Contenedor acero-inox**  
**Tapa con pedal. Tapa extraíble**

Stainless steel container  
Pedal-lift top. Removable top

*Conteneur acier inox*  
*Couvercle avec pédale. Couvercle amovible*

Ref.	Díámetro Diameter Diamètre	Altura Height Hauteur	Capacidad Capacity Capacité	Euros
WI-60	Ø 40 cm	60 cm	60 l	374,00

0

6

**Indicadores de turno, Expendedores de tickets, Impresora de tickets, Rollo tickets, Organizador de filas, Exterminadores de insectos, Detector contador billetes - monedas, Reloj-temperatura.**

---

Queue indicators, Ticket dispenser, Tickets printer, Ticket roll, Row organizer, Insect exterminator, Counter detector bill - coin, Clock - temperature.

---

*Indicateur de numero, Dispensateu tickets, Imprimante tickets, Rouleaux de tickets, Organisateur de rangée, Exterminateur d'insectes, Compteur détecteur billets - monnaie, Horloge - température.*

**121 - 134**



**Indicador de turno**  
**Visor de dos dígitos con mando a distancia.**

Queue indicator  
Two-digit screen with remote control.

*Indicateur de numéro*  
*Visseur à deux chiffres avec commande à distance*

Ref.	Medidas Size Dimensions	Altura dígitos (cm) Digits height (cm) Hauteur chiffres (cm)	Voltaje (V) Voltage (V) Voltage (V)	Euros
IT-5-MD	30 x 26 cm	13	220	256,00



**Indicador de turno**  
**Visor de dos dígitos y mando a distancia con visor.**

Queue indicator  
Two-digit screen with remote control with screen.

*Indicateur de numéro*  
*Visseur à deux chiffres et commande à distance avec viseur*

Ref.	Medidas Size Dimensions	Altura dígitos (cm) Digits height (cm) Hauteur chiffres (cm)	Voltaje (V) Voltage (V) Voltage (V)	Euros
IT-5-MDV	30 x 32 cm	13	220	278,00



**Indicador de turno**  
**Visor de dos dígitos con mando con cable de 1 función.**

Queue indicator  
Two-digit screen with control pad with cable 1 function.

*Indicateur de numéro*  
*Visseur à deux chiffres et commande avec fil 1 fonction.*

Ref.	Medidas Size Dimensions	Altura dígitos (cm) Digits height (cm) Hauteur chiffres (cm)	Voltaje (V) Voltage (V) Voltage (V)	Euros
IT-6-ECO	34,5 x 24 cm	12,5	220V	189,00



**Indicador de turno**  
**Visor de dos dígitos con mando con cable de 3 funciones.**

Queue indicator  
Two-digit screen with control pad with cable 3 function.

*Indicateur de numéro*  
*Visseur à deux chiffres et commande avec fil 3 fonctions.*

Ref.	Medidas Size Dimensions	Altura dígitos (cm) Digits height (cm) Hauteur chiffres (cm)	Voltaje (V) Voltage (V) Voltage (V)	Euros
IT-6	34,5 x 24 cm	12,5	220V	295,00

**Indicador de turno. Visor de dos dígitos con mando con cable estanco de 1 función.**

Queue indicator. Two-digit viewfinder with remote control with waterproof cable 1 function.

*Indicateur de numéro. Viseur à deux chiffres avec télécommande avec câble étanche 1 fonction.*

Ref.	Medidas Size Dimensions	Altura dígitos (cm) Digits height (cm) Hauteur chiffres (cm)	Voltaje (V) Voltage (V) Voltage (V)	Euros
IT-6-E	34,5 x 24 cm	12,5	220V	292,00

**Indicador de turno. Visor de dos dígitos con mando con cable. Conexión balanzas Dibal de 1 función.**

Queue indicator. Two-digit screen with control pad with cable. Dibal balance connection 1 function.

*Indicateur de numéro. Viseur à deux chiffres et commande avec fil. Connexion balance Dibal 1 fonction.*

Ref.	Medidas Size Dimensions	Altura dígitos (cm) Digits height (cm) Hauteur chiffres (cm)	Voltaje (V) Voltage (V) Voltage (V)	Euros
IT-6-B	34,5 x 24 cm	12,5	220V	220,00





**Indicador de turno**  
**Visor dos dígitos con mando a distancia de 1 función.**

Queue indicator  
 Two-digit screen with remote control 1 function.

*Indicateur de numéro*  
*Viseur à deux chiffres et commande à distance 1 fonction.*

Ref.	Medidas Size Dimensions	Altura dígitos (cm) Digits height (cm) Hauteur chiffres (cm)	Voltaje (V) Voltage (V) Voltage (V)	Euros
IT-6-MD-ECO	34,5 x 24 cm	12.5	220	189,00



**Indicador de turno. Visor dos dígitos con mando a distancia de 4 funciones. Con 9 colores de dígitos.**

Queue indicator. Two-digit screen with remote control 4 functions.  
 With 9 digit colors.

*Indicateur de numéro. Viseur à deux chiffres et commande à distance 4 fonctions. Avec des couleurs à 9 chiffres.*

Ref.	Medidas Size Dimensions	Altura dígitos (cm) Digits height (cm) Hauteur chiffres (cm)	Voltaje (V) Voltage (V) Voltage (V)	Euros
IT-6-MD	34,5 x 24 cm	12.5	220	306,00



**Indicador de turno. Visor dos dígitos con cable y visor, adelanta, retrocede. Numérico**

Queue indicator. Two-digit screen with remote control pad with cable and screen, goes forward and back and can select numbers. Numeric.

*Indicateur de numéro*  
*Viseur à deux chiffres et commande à distance avec fil et viseur, avance et recule et sélection numérique*

Ref.	Medidas Size Dimensions	Altura dígitos (cm) Digits height (cm) Hauteur chiffres (cm)	Voltaje (V) Voltage (V) Voltage (V)	Euros
IT-6-X	34,5 x 24 cm	12.5	220	485,00



**Indicador de turno**  
**Batería 12v. Visor dos dígitos. Mando a distancia**

Queue indicator  
 Battery 12V. Two digit-screen. Remote control

*Indicateur de numéro*  
*Viseur à deux chiffres batterie 12 V télécommande.*

Ref.	Medidas Size Dimensions	Voltaje (V) Voltage (V) Voltage (V)	Altura dígitos (cm) Digits height (cm) Hauteur chiffres (cm)	Euros
IT-7-MD	28 x 24,5 cm	220V/12V	15	243,00



**Indicador de turno**  
**Visor dos dígitos. Mando con cable de 2 funciones.**

Queue indicator  
 Two-digit screen with control pad with cable 2 functions.

*Indicateur de numéro*  
*Viseur à deux chiffres et commande avec fil 2 fonctions.*

Ref.	Medidas Size Dimensions	Altura dígitos (cm) Digits height (cm) Hauteur chiffres (cm)	Voltaje (V) Voltage (V) Voltage (V)	Euros
IT-8	24,5 x 15 cm	9.5	110V - 220V	198,00



**Indicador de turno**  
**Visor dos dígitos. Mando a distancia de 2 funciones.**

Queue indicators  
2 digits screen remote control 2 functions.

*Indicateur de numéro*  
*Viseur à deux chiffres. Télécommande 2 fonctions.*

Ref.	Medidas Size Dimensions	Altura dígitos (cm) Digits height (cm) Hauteur chiffres (cm)	Voltaje (V) Voltage (V) Voltage (V)	Euros
IT-8-MD	24,5 x 15 cm	9.50	110V - 220V	198,00



**Indicador de turno. Visor 2 dígitos. Mando a distancia.**  
**Kit: pantalla + mando + dispensador rojo + 1 rollo + cartel**

Queue indicators. Two digit screen remote control.  
Kit: screen + control + red dispenser + 1 roll + poster

*Indicateur de numéro. Viseur à deux chiffres. Télécommande.*  
*Kit: écran + contrôle + distributeur rouge + 1 rouleau + poster*

Ref.	Medidas Size Dimensions	Altura dígitos (cm) Digits height (cm) Hauteur chiffres (cm)	Voltaje (V) Voltage (V) Voltage (V)	Euros
IT-9-MD	30 x 20 cm	10	220 V	225,00



**Indicador de turno.**  
**Visor 3 dígitos, mando con cable de 3 funciones.**

Queue indicator  
Three-digit screen, control pad with cable 3 functions.

*Indicateur de numéro*  
*Viseur 3 chiffres, commande avec fil 3 fonctions.*

Ref.	Medidas Size Dimensions	Altura dígitos (cm) Digits height (cm) Hauteur chiffres (cm)	Voltaje (V) Voltage (V) Voltage (V)	Euros
IT-4	34,5 x 24 cm	12.5	220	293,00



**Indicador de turno**  
**Visor 3 dígitos con mando a distancia de 4 funciones.**

Queue indicator  
3 digits screen with remote control 4 functions.

*Indicateur de numéro*  
*Viseur 3 chiffres avec télécommande 4 fonctions.*

Ref.	Medidas Size Dimensions	Altura dígitos (cm) Digits height (cm) Hauteur chiffres (cm)	Voltaje (V) Voltage (V) Voltage (V)	Euros
IT-4-MD	34,5 x 24 cm	12.5	220	309,00



**Indicador de turno**  
**Visor 3 dígitos, mando con cable y visor. Adelanta, retrocede y selección numérico**

Queue indicator  
 Three digits screen, control cable pad, goes back and forward.

*Indicateur de numéro*  
*Viseur 3 chiffres, commande avec fil, avance et recule*

Ref.	Medidas Size Dimensions	Altura dígitos (cm) Digits height (cm) Hauteur chiffres (cm)	Voltaje (V) Voltage (V) Voltage (V)	Euros
IT-4-X	34,5 x 24 cm	12,5	220	740,00



**Indicador de turno**  
**Visor 2 dígitos + 1 dígito punto atención. Mando con visor.**

Queue indicator  
 2+1 digit screen. Control pad with screen.

*Indicateur de numéro*  
*Viseur 2 chiffres avec lieu d'attention*

Ref.	Medidas Size Dimensions	Altura dígitos (cm) Digits height (cm) Hauteur chiffres (cm)	Voltaje (V) Voltage (V) Voltage (V)	Euros
IT-10	34,5 x 24 cm	12,95 / 9,5	220	850,00

**Mando con visor para ref. IT-10**

Control pad with screen for ref. IT-10

*Commande avec viseur pour réf. IT-10*

Ref.	Euros
IT-10-1	120,00



**Indicador de turno con punto de atención**  
**Visor 3+1 dígitos. Mando con visor. Base telefónica.**

Queue indicator displaying free counter number  
 3+1 digit screen. Control pad with screen.

*Écran indicateur de numéro avec lieu d'attention*  
*Viseur à 3+1 chiffres.*

Ref.	Medidas Size Dimensions	Altura dígitos (cm) Digits height (cm) Hauteur chiffres (cm)	Voltaje (V) Voltage (V) Voltage (V)	Euros
IT-11	34,5 x 24 cm	12,5 x 9,5	220	853,00

**Mando con visor para ref. IT-11**

Control pad with screen for ref. IT-11

*Commande avec viseur pour réf. IT-11*

Ref.	Euros
IT-11-1	120,00



**Indicador de turno**  
**Panel 3 secciones. Visor 2+4 dígitos. Mando con cable.**

Queue indicator  
 3-section panel. 2+4 digits screen. Control pad with cable.

*Indicateur de numéro*  
*Panneau 3 sections. Viseur à 2+4 chiffres. Commande avec fil.*

Ref.	Medidas Size Dimensions	Altura dígitos (cm) Digits height (cm) Hauteur chiffres (cm)	Voltaje (V) Voltage (V) Voltage (V)	Euros
IT-30	54 x 40 cm	12,5 + 9,5	220	909,00



**Indicador de turno**  
**Panel de 3 secciones. Visor 2+4 dígitos. Mando a distancia.**

Queue indicator  
 Panel 3 secciones. 2+4 digit screen. Remote control.

*Panel 3 sections. Viseur à 2+4 chiffres. Commande à distance.*

Ref.	Medidas Size Dimensions	Altura dígitos (cm) Digits height (cm) Hauteur chiffres (cm)	Voltaje (V) Voltage (V) Voltage (V)	Euros
IT-30-MD	54 x 40 cm	12,5 x 9,5	220	909,00

INDICADOR TEMPERATURA | TEMPERATURE WARNING | INDICATEUR DE TEMPÉRATURE



**Panel temperatura / humedad**  
**Dígitos 9,5 cm**

Temperature warning  
 Temperature / humidity noticeboard. Digits 9,5 cm

*Indicateur de température*  
*Tableau de température / humidité. Chiffres 9,5 cm.*

Ref.	Medidas Size Dimensions	Euros
ITH-95	7 x 32 x 48 cm	909,00



**Reloj - temperatura**  
**Carcasa metálica. 4 dígitos 12,5 rojos. Mando a distancia**

Clock - temperature  
 Metal housing. 4 red digits 12.5. Remote control

*Horloge - température*  
*Boîtier en métal. 4 chiffres rouges 12.5. Télécommande*

Ref.	Medidas Size Dimensions	Euros
ITR-125	63,5 x 30,5 cm	848,00



**Columna epoxi negro para expendedor ET-1 no incluido. Incluye cartel.**

Black epoxy stand for ET-1 ticket dispenser

*Colonne époxy noir pour dispensateur ET-1*

Ref.	Altura (cm) Height (cm) Hauteur (cm)	Euros
ET-15	136 cms	143,00



**Expendedor impresora térmica Ticket hasta 4 secciones**

Thermal printer dispenser  
Ticket up to 4 sections

*Dispensateur d'imprimante thermique  
Ticket jusqu'à 4 sections*

Ref.	Euros
ET-100	1350,00



**Columna acero inoxidable para expendedor ET-1 no incluido.**

Stainless steel column for dispenser ET-1 not included.

*Colonne en acier inoxydable pour distributeur ET-1 non inclus.*

Ref.	Altura (cm) Height (cm) Hauteur (cm)	Euros
ET-10	135 cms	84,00



**Soporte pie expendedor ET-100**

Food stand dispenser ET-100

*Support pied dispensateur ET-100*

Ref.	Euros
ET-100-S	210,00



**Soporte pared expendedor ET-100**

Wall stand dispenser ET-100

*Support mural dispensateur ET-100*

Ref.	Euros
ET-100-P	103,00



**Expendedor de tickets**

Ticket dispenser

Dispensateur tickets

Ref.	Color Colour Couleur	Euros
ET-1-A	●	19,00
ET-1-AZ	●	19,00
ET-1-B	○	19,00
ET-1-G	●	19,00
ET-1-N	●	19,00
ET-1-NA	●	19,00
ET-1-R	●	19,00
ET-1-V	●	19,00

**Rollos tickets dos dígitos (2000 números)**

Two digits tickets rolls (2000 numbers)

Rouleaux de tickets deux chiffres (2000 numéros)

Ref.	Color Colour Couleur	Unidades Units Unités	Euros
RT-5-A	●	10	21,00
RT-5-AZ	●	10	21,00
RT-5-B	○	10	21,00
RT-5-R	●	10	21,00
RT-5-V	●	10	21,00

**Rollos de tickets tres dígitos (2000 números)**

Three digit ticket roll (2000 numbers)

Rouleaux de tickets (2000 numéros)

Ref.	Color Colour Couleur	Unidades Units Unités	Euros
RT-6-A	●	10	22,00
RT-6-AZ	●	10	22,00
RT-6-B	○	10	22,00
RT-6-R	●	10	22,00
RT-6-V	●	10	22,00

**ORGANIZADOR DE FILAS | ROW ORGANIZER | ORGANISATEUR DE RANG**



**Postes acero inoxidable pintado negro con cinta extensible 2 metros**

Black painted stainless steel posts with extensible strap 2 meters

Poteaux en acier inoxydable peint en noir avec sangle extensible 2 mètres

Ref.	Color Colour Couleur	Medidas Size Dimensions	Unidades Units Unités	Euros
OR-2	●●●	32 x 90 cm	pack 2 UND	110,00

Otros colores consultar.  
Consult other colors.  
Consultez d'autres couleurs.



**Banda mural acero inoxidable pintado negro con cinta extensible 2 metros**

Black painted stainless steel wall band with tape extendable 2 meters

Bande murale en acier inoxydable peint en noir avec du ruban adhésif extensible 2 mètres

Ref.	Color Colour Couleur	Euros
OR-2M	●●●	33,00

Otros colores consultar.  
Consult other colors.  
Consultez d'autres couleurs.



**Exterminador de insectos**  
**Posición suspendido ó sobre su base, material de policarbonato.**

Electric insect exterminator  
 Positioning hanging or standing on its base, material a polycarbonate.

*Exterminateur d'insectes décharge électrique*  
*Pose suspendu ou sur sa base, matériel polycarbonate.*

Ref.	Medidas Size Dimensions	Voltaje Voltage Voltage	Tensión reja (V) Grid voltage (V) Tension grille (V)	Tubo luz actínica Actinic light tube Tube éclairage actinique	Superficie máxima (m²) Tube maximum surface (m²) Surface maximum (m²)	Euros
Z-151	13 x 16 x 34,5 cm	220 V 50Hz	4000	1 x 11W	110	38,50



**Exterminador de insectos por descarga eléctrica**  
**Con mando a distancia, posición suspendido ó sobre su base, material ABS-Aluminio.**

Electric insect killer  
 With remote control, positioning can hang on wall or stand on its base, material ABS-Aluminium.

*Exterminateur d'insectes décharge électrique*  
*Avec télécommande, pose suspendu ou sur sa base, matériel ABS-Alumin.*

Ref.	Medidas Size Dimensions	Voltaje Voltage Voltage	Tensión reja (V) Grid voltage (V) Tension grille (V)	Tubo luz actínica Actinic light tube Tube éclairage actinique	Superficie máxima (m²) Tube maximum surface (m²) Surface maximum (m²)	Euros
Z-420-MD	39 x 30 x 10 cm	220-240 V	2000	2 x 10 W	300	85,00
Z-430-MD	49 x 34 x 10 cm	220-240 V 50 HZ	2000	2 x 15W	380	109,00
Z-440-MD	64 x 39 x 10 cm	220-240 V 50 HZ	2000	2 x 20W	451	125,00

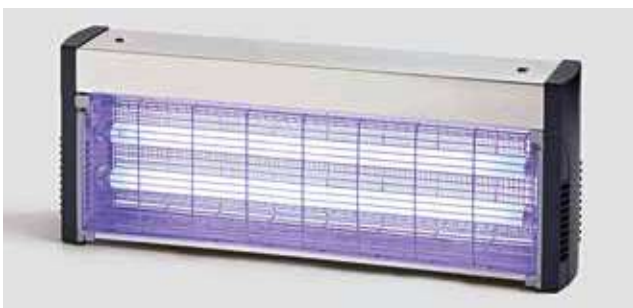

**Exterminador de insectos**  
**Posición suspendido ó sobre su base, material acero-inox.**

Insect exterminator  
 Positioning can hang on wall or stand on its base, material stainless steel.

*Exterminateur d'insectes*  
*Pose suspendu ou sur sa base, matériel acier-inox.*

Ref.	Medidas Size Dimensions	Voltaje Voltage Voltage	Tensión reja (V) Grid voltage (V) Tension grille (V)	Tubo luz actínica Actinic light tube Tube éclairage actinique	Superficie máxima (m²) Tube maximum surface (m²) Surface maximum (m²)	Euros
Z-600	30 x 28 x 14 cm	220V 50/60Hz	2310V	2 x 11 W	300	109,00
Z-700	57 x 28 x 14 cm	220V 50/60Hz	5650	2 x 15W	380	135,00
Z-780	69 x 28 x 14 cm	220 V	4000	2 x 40W	600	168,00

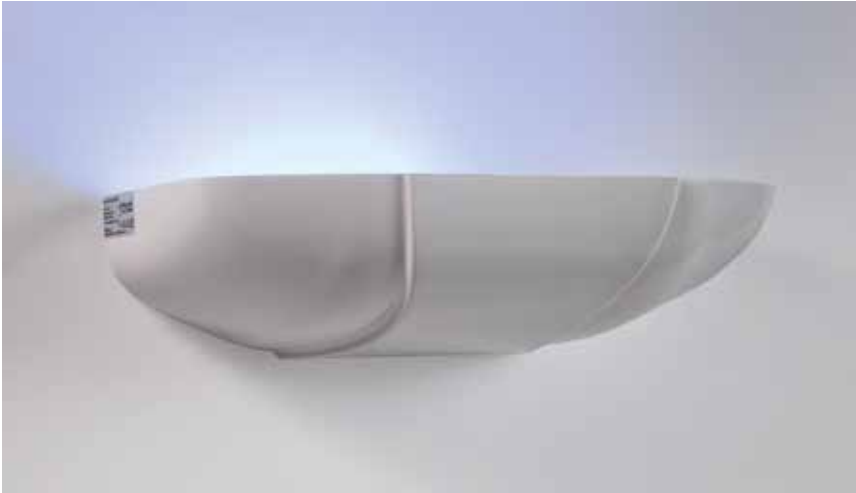

**Trampa adhesiva**  
Para ref. Z-911. Paquete 6 unidades

Adhesive trap  
For ref. Z-911. Pack 6 units

*Piège adhésif*  
*Pour réf. Z-911. 6 unités*

Ref.	Unidades Units Unités	Euros
Z-911-A	6	20,00

**Exterminador de insectos con trampa adhesiva**  
Lámpara 1x20 W bajo consumo, ABS blanco

Adhesive insect trap  
Lamp 1x20 V, low energy, white ABS

*Exterminateur d'insectes piège adhésif*  
*Lampe 1x20 W, basse consommation, ABS blanc*

Ref.	Color Colour Couleur	Medidas Size Dimensions	Voltaje Voltage Voltage	Lámpara luz actínica Actinic light lamp Lampe éclairage actinique	Euros
Z-911	○	49 x 19,7 x 10 cm	220 V	1 x 20 W	49,50
Z-911-N	●	49 x 19,7 x 10 cm	220 V	1 x 20 W	63,00



**Lamina adhesiva**  
Para ref. Z-918. Paquete 6 unidades

Adhesive replacement  
For Ref. Z-918, pack 6 units

*Rechange adhésif*  
*Pour réf. Z-918.*

Ref.	Unidades Units Unités	Euros
Z-918-A	6	20,00

**Exterminador de insectos con trampa adhesiva**  
Posición pared (applique), material metálico Epoxi.

**Recambio adhesiva : ref. Z-918-A**

Adhesive insect trap  
Positioning wall light, material metallic epoxy.

Adhesive replacement : ref. Z-918-A

*Exterminateur d'insectes piège adhésif*  
*Pose mur (applique), matériel métalloque époxy.*

*Rechange adhésif : réf. Z-918-A*

Ref.	Color Colour Couleur	Medidas Size Dimensions	Voltaje Voltage Voltage	Lámpara luz actínica Actinic light lamp Lampe éclairage actinique	Euros
Z-918	○	45,5 x 18,7 x 15,5 cm	220 V	1 x 20W	98,00
Z-918-N	●	45,5 x 18,7 x 15,5 cm	220	1 x 20W	98,00



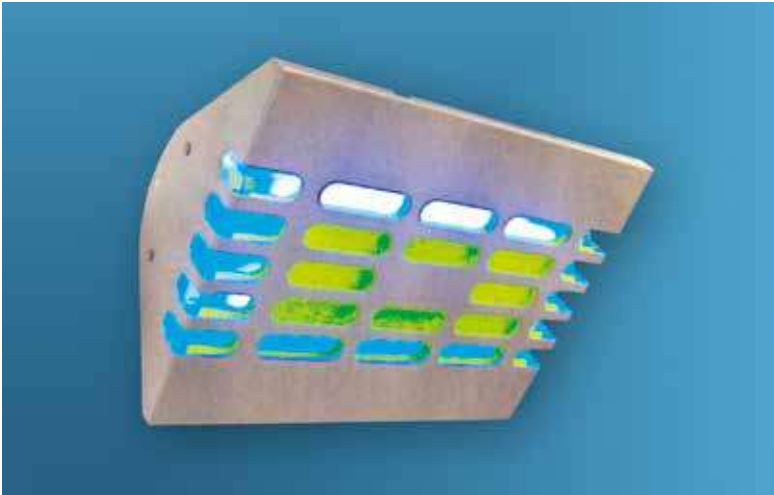

**Exterminador de insectos con trampa adhesiva**  
**Posición suspendido pared, material acero-inox.**

**Recambio adhesiva : ref. Z-950-A**

Adhesive insect trap  
 Positioning hung on wall, material stainless steel.

Adhesive replacement : ref. Z-950-A

*Exterminateur d'insectes piège adhésif*  
*Pose suspendu mur, matériel acier-inox.*

*Rechange adhésif : réf. Z-950-A*

Ref.	Medidas Size Dimensions	Voltaje Voltage Voltage	Tubo luz actínica Actinic light tube Tube éclairage actinique	Euros
Z-950	47 x 35,5 x 18,5 cm	220	2 x 15W	199,00

**Lamina adhesiva**  
**Para ref. Z-950/Z-955. Paquete 6 unidades**

Adhesive replacement  
 For ref. Z-960. Pack 6 units

*Réchange adhésif*  
*Pour ref. Z-960-A. 6 unités.*

Ref.	Unidades Units Unités	Euros
Z-950-A	6	32,00



**Exterminador de insectos con trampa adhesiva.**  
**Estanco IP65. Para ambientes con alto nivel de humedad. Posición suspendido, material acero-inox.**  
**Recambio adhesivo: ref. Z-960-A**

Adhesive insect trap.  
 Waterproof. Suitable to work under high humidity ambient. Hung position. Stainless Steel made.

Adhesive replacement: ref. Z-960-A

*Exterminateur d'insectes piège adhésif*  
*Imperméable. Adéquat pour fonctionner dans ambient avec haut humidité. Position suspendu.*  
*Fabriqué en acier inoxydable.*  
*Réchange adhésif: réf. Z-960-A*

Ref.	Medidas Size Dimensions	Voltaje Voltage Voltage	Tubo luz actínica Actinic light tube Tube éclairage actinique	Euros
Z-960	67 x 32,5 x 18,5 cm	220	2 x 20 W	220,00

**Lamina adhesiva**  
**Para ref. Z-960. Paquete 6 unidades**

Adhesive replacement  
 For ref. Z-960-A. Pack 6 units

*Réchange adhésif*  
*Pour ref.Z-960-A. 6 unités*

Ref.	Unidades Units Unités	Euros
Z-960-A	6	34,00



**Lamina adhesiva  
Para ref. Z-930. Paquete 6 unidades**

Adhesive replacement  
For ref. Z-940. Pack 6 units

Réchange adhésif  
Pour ref. Z-940. 6 unités.

Ref.	Unidades Units Unités	Euros
Z-930-A	6	32,00

**Exterminador de insectos con trampa adhesiva dos caras.  
Acabado acero inox / ABS**

**Posición suspendido o sobre su base**

**Recambio adhesivo: Z-930-A**

Insect exterminator with two-sided adhesive trap.  
Stainless steel / ABS made

Position suspended or on its base

Adhesive refill: Z-930-A

Exterminateur d'insectes avec piège adhésif double face.  
Fabriqué en acier inoxydable / ABS

Position suspendue ou sur son socle

Recharge adhésive: Z-930-A

Ref.	Medidas Size Dimensions	Voltaje Voltage Voltage	Tubo luz actínica Actinic light tube Tube éclairage actinique	Euros
Z-930	57 x 28 x 14 cm	220	2 x 15W	128,00

**DETECTOR CONTADOR BILLETES - MONEDAS | COUNTER DETECTOR BILL - COIN | COMPTEUR DÉTECTEUR BILLETS - MONNAIE**



**Detector de billetes electrónico arrastre automático, batería**

Electronic note detector with automatic drag / détecteur, batterie

Détecteur de billets électronique avec déplacement automatique,  
batterie

Ref.	Voltaje (V) Voltage (V) Voltage (V)	Euros
A-530	220 V	190,00

**Detector de billetes electrónico arrastre automático**

Electronic note detector with automatic drag

Détecteur de billets électronique avec déplacement automatique

Ref.	Voltaje (V) Voltage (V) Voltage (V)	Euros
A-531	220 V	156,00



**Contador separador monedas EURO**

Coin serter EURO

*Compteur séparateur de monnaie EURO*

Ref.	Voltaje (V) Voltage (V) Voltage (V)	Euros
A-540	220 V	398,00



**Detector contador billetes distinto valor EURO**

Counteur detector different value bill EURO

*Compteur detecteur billets de valeur différente EURO*

Ref.	Voltaje (V) Voltage (V) Voltage (V)	Euros
A-550	220 V	950,00



**Detector contador billetes igual valor EURO**

Counteur detector equal value bill EURO

*Compteur detecteur billets du même valeur EURO*

Ref.	Voltaje (V) Voltage (V) Voltage (V)	Euros
A-555	220 V	390,00



0

7

**Hamburgueseras, Papel celofán, Embutidoras,  
Jamoneras, Jamonero rotatorio 360°, Ganchos,  
Libradores, Pinzas, Molde brochetas,  
Enternecedor carne, Malla y anillas elásticas,  
Protector hueso, Termómetros.**

---

Hamburger presses, Cellophane foil, Sausage  
filler, Jamoneras, Rotary Ham holder 360°,  
Hooks, Scoops, Tongs, Brochette mold, Meat  
tenderizer, Elastic mesh and rings, Bone  
protector, Thermometer.

---

*Hachoirs, Papiers cellophane, Emboutisseuses,  
Jamoneras, Support de jambon rotatif 360°,  
Crochets, Pelles à main, Pincés, Moule brochettes,  
Attendrisseur, Maille et anneaux élastiques,  
Protecteur d'os, Thermomètre.*

**135 - 148**



**Hamburguesera carcasa aluminio de 1 unidad ovalada 11x8**

Aluminium hamburger press, 1 oval shaped unit 11x8

*Hachoir carcasse aluminium pour 1 unité ovale 11x8*

Ref.	Diámetro Diameter Diamètre	Euros
MH-1	OVAL 11 x 8 cm	66,00



**Hamburguesera aluminio 1 unidad redonda 10 cm diámetro**

Aluminium hamburger 1 unit rounded 13 cm diameter

*Hachoir aluminium 1 unité ronde 10 cm diamètre*

Ref.	Diámetro Diameter Diamètre	Euros
MH-1-R	Ø 10 cm	69,00



**Hamburguesera carcasa aluminio de 2 unidades ovalada 11x8**

Aluminium hamburger press, 2 oval shaped units 11x8

*Hachoir carcasse aluminium pour 2 unités ovales 11x8*

Ref.	Diámetro Diameter Diamètre	Euros
MH-2	OVAL 11 x 8 cm	230,00



**Hamburguesera acero-inox de 2 unidades ovalada 11x8**

Stainless steel hamburger press, 2 oval shaped units 11x8

*Hachoir acier inox pour 2 unités ovale 11x8*

Ref.	Diámetro Diameter Diamètre	Euros
MH-3	OVAL 11 X 8	311,00



**Hamburguesera acero-inox de 4 unidades ovalada 11x8**

Stainless steel hamburger 11x8

*Hachoir acier inox pour 4 unités ovale 11x8*

Ref.	Diámetro Diameter Diamètre	Euros
MH-4	OVAL 11 x 8 cm	365,00



**Hamburguesera acero-inox 2 unidades redonda**

Stainless steel hamburger press, 2 round units

*Hachoir acier inox pour 2 unités rondes*

Ref.	Diámetro Diameter Diamètre	Euros
MH-5	Ø 10 cm	301,00



**Hamburguesera aluminio 2 unidades.**

Aluminium hamburger press 2 units.

*Hachoir aluminium 2 unités.*

Ref.	Diámetro Diameter Diamètre	Euros
MH-8	Ø 10 cm	255,00



**Máquina hamburguesas aluminio 2 unidades. Redonda 6,5 cm diámetro**

Aluminum hamburger machine 2 round units 6,5 cm diameter

*Machine à hamburger aluminium 2 unités ronde 6,5 cm diameter*

Ref.	Diámetro Diameter Diamètre	Euros
MH-9	Ø 6,5 cm	255,00



**Máquina hamburguesa semi-automática**  
**Molde acero 1 unidad inox. Tipo papel celofán ref. PH-6. Contenedor para papel celofán incorporado. Funcionamiento: mediante brazo de mando que permite de modo sincronizado la compresión y extracción de la hamburguesa.**

Semi-automatic hamburger press  
 Round stainless steel mold for one unit.  
 Cellophane foil type ref. PH-6. Features cellophane foil container. Working: move lever for synchronised compression and removal from the hamburger press.

*Hachoir semi-automatique*  
 Moule en acier inox rond pour 1 unité. Type papier cellophane réf.: PH-6. Conteneur pour papier cellophane incorporé. Fonctionnement: au moyen d'un bras qui permet de façon synchronisée la compression et l'extraction du hamburger.

Ref.	Diámetro Diameter Diamètre	Euros
MH-10	Ø 10 cm	438,00



**Maquina hamburguesa semi-automática**  
**1 unidad en acero inox. Tipo papel celofán ref. PH-7. Características igual ref. MH-10**

Semi-automatic hamburger press  
 Single round stainless steel mold.  
 Cellophane foil type PH- 7. Features sam as ref. MH-10

*Hachoir semi-automatique*  
 1 moule en acier inox rond. Type papier cellophane réf PH-7. Même caractéristiques ref. MH-10

Ref.	Diámetro Diameter Diamètre	Euros
MH-13	Ø 13 cm	466,00



**Maquina hamburguesa semi-automática**  
**1 unidad en acero inox. redonda. Tipo papel celofán ref. PH-8. Características igual ref. MH-10**

Semi-automatic hamburger press  
 Single round stainless steel mold.  
 Cellophane foil type PH- 8. Features sam as ref. MH-10

*Hachoir semi-automatique*  
 1 moule en acier inox rond. Type papier cellophane réf PH-8. Même caractéristiques ref. MH-10

Ref.	Diámetro Diameter Diamètre	Euros
MH-15	Ø 15 cm	499,00



**Hamburguesa**  
**1 unidad**

Hamburger press  
 1 unit.

*Hachoir*  
 1 unité.

Ref.	Diámetro Diameter Diamètre	Euros
MH-6	Ø 13 cm	301,00



**Hamburguesa**  
**2 unidades.**

Hamburger press  
 2 units.

*Hachoir*  
 2 unités.

Ref.	Diámetro Diameter Diamètre	Euros
MH-7	Ø 13 cm	382,00

**Molde 1 unidad redonda con expulsor hamburguesa ACERO-INOX.**

1 unit round mould. Stainless steel.

Moule 1 unité ronde. Acier inoxydable.

Ref.	Diámetro Diameter Diamètre	Euros
MH-25	Ø 5 cm	79,00
MH-20	Ø 6,5 cm	79,00
MH-21	Ø 10 cm	103,00
MH-22	Ø 13 cm	135,00
MH-23	Ø 15 cm	161,00



**Paquete papel celofán redondo BIODEGRADABLE Y COMPOSTABLE**

Packet of round cellophane foil

Paquet papier cellophane rond

Ref.	Diámetro Diameter Diamètre	Unidades Units Unités	Euros
PH-3	Ø 5 cm	900	5,80
PH-4	Ø 6,5 cm	450	3,60
PH-6	Ø 10 cm	350	5,30
PH-5	OVAL 11 x 8 cm	450	4,50
PH-7	Ø 13 cm	350	9,80
PH-8	Ø 15 cm	350	12,80

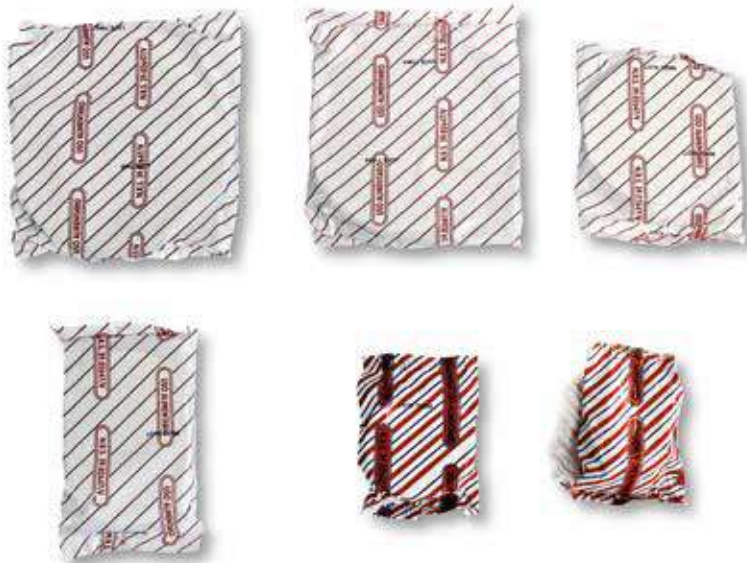

**Separador Interloncheados**

Separator slices

Tranches de séparateur

Ref.	Medidas Size Dimensions	Unidades Units Unités	Euros
PS-60	160 x 60 mm	500	7,50
PS-70	160 x 70 mm	500	8,50
PS-80	160 x 80 mm	500	9,50





**Embutidoras inox**

Stainless steel sausage fillers

*Emboutisseuses acier inoxydable*

Ref.	Medidas Size Dimensions	Capacidad Capacity Capacité	Euros
ME-L5	55 x 19 x 21,5 cm	5 kg	374,00
ME-L8	65 x 19 x 21,5 cm	8 kg	402,00
ME-L8V	30 x 32 x 79 cm	8 kg	497,00



**Embutidoras inox**

Stainless steel sausage fillers

*Emboutisseuses en acier inoxydable*

Ref.	Medidas Size Dimensions	Peso Weight Poids	Capacidad Capacity Capacité	Euros
ME-L7	69 x 24 x 24 cm	27 kg	7 l	1036,00
ME-L14	84 x 28 x 29 cm	35 kg	14 l	1266,00



**Despiece / Quartering / Dépeçage**

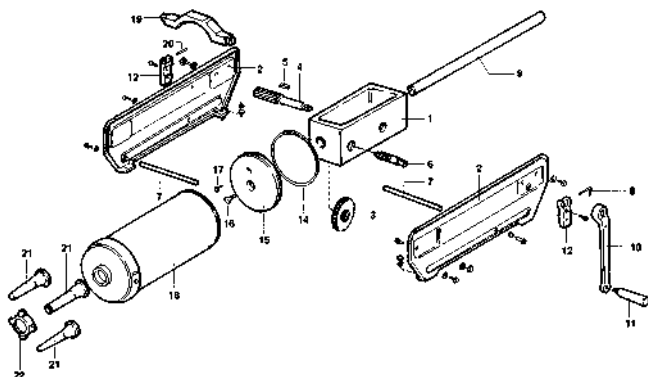

**Medidas / Size / Dimensions**

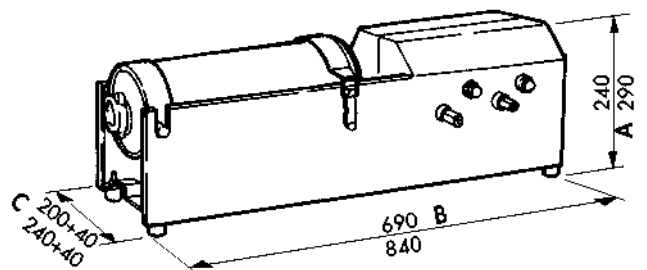

**Juego 4 embudos inyección embutidora**

Set of 4 injection filler funnels

*Ensemble 4 entonnoirs injection emboutisseuses*

Ref.	Euros
A-37	28,00



**Sujeta jamones  
Rústico, base madera**

Ham holder  
Rustic wooden base

*Présentoir jambons  
Rustique base bois*

Ref.	Euros
SJ-4	82,00



**Sujeta jamón  
Sobremesa o pared - base polietileno**

Ham holder  
Free standing or fixed to wall - polyethylene base

*Serre-jambon  
Sur table ou mur - base polyéthylène*

Ref.	Euros
SJ-5-M	112,00



**Sujeta jamones  
Base y brazo polietileno blanco**

Ham holder  
White polyethylene base

*Présentoir jambons  
Base en polyéthylène blanche*

Ref.	Euros
SJ-6-B	56,00



**Sujeta jamones  
Acero inox, soporte regulable**

Ham holder  
Stainless steel fittable support

*Présentoir jambons  
Inox. pied réglable*

Ref.	Euros
SJ-8	148,00



**Sujeta jamones  
Fijo soporte madera**

Ham holder  
Black removable arm, wooden base

*Présentoir jambons  
Bras démontable bois, base bois*

Ref.	Euros
SJ-9	3750



**Expositor jamones 20 unidades con  
ruedas**

Wheel exhibitor ham 20 units

*Présentoir jambons 20 unités avec roulettes*

Ref.	Altura Height Hauteur	Euros
SJ-20	225 cm	234,00



**Sujeta jamones  
Articulado giratorio inox base madera**

Ham holder  
Articulated rotating inox base wood

*Présentoir jambons  
Base articulée tournante inox, base en bois*

Ref.	Euros
SJ-10	175,00



**Sujeta jamones giratorio inox con base madera.**

Subject based steel rotating wooden ams

*Acier à base de bois objet rotatif jambons*

Ref.	Euros
SJ-15	297,00



**Sujeta jamones  
Articulado giratorio 360° inox base polietileno negro**

Ham holder  
Articulated rotating 360° inox base black polyethylene

*Présentoir jambons  
Base articulée tournante 360° inox, base en polyéthylène noir*

Ref.	Euros
SJ-16	450,00



**Sujeta jamones giratorio 360° inox base madera de encina**

Subject based steel rotating 360° oak wooden ams

*Acier à base de bois de chêne objet rotatif 360° pour jambons*

Ref.	Euros
SJ-18	467,00

**Mesa jamonera con soporte jamón inox giratorio**

Ham table with stainless rotary ham holder

*Table avec porte-jambon rotatif inox*

Ref.	Medidas Size Dimensions	Euros
SJ-500	60 x 50 x 85 cm	528,00



**Mesa jamonera con soporte jamón inox giratorio 360°  
Encimera madera de encina con dos estantes**

Ham table with stainless rotary 360° ham holder  
Oak wood countertop with two shelves

*Table jambon avec porte-jambon rotatif inox, 60 x 50 x 85 / 120  
Comptoir en chêne avec deux tablettes*

Ref.	Medidas Size Dimensions	Euros
SJ-600	60 x 50 x 85 cm	785,00

**Mesa jamonera con soporte jamón inox giratorio 360°  
Encimera madera de encina con dos estantes y dos ruedas giratorias con freno. Encimera madera de encina con dos estantes**

Ham table with stainless rotary 360° ham holder  
Oak wood countertop with two shelves and two rotating wheels with brake

*Table jambon avec porte-jambon rotatif inox, 60 x 50 x 85 / 120  
Comptoir en chêne avec deux tablettes et deux roues tournantes avec frein*

Ref.	Medidas Size Dimensions	Euros
SJ-600-R	60 x 50 x 85 cm	822,00





**Cono escurrejamonos**

Ham drain cone

*Cône égouttoir à jambon*

Ref.	Unidades Units Unités	Euros
A-3	6	9,00



**Colgador jamones  
12 unidades**

Ham hanger  
12 units

*Porte jambons  
12 unités*

Ref.	Euros
SJ-12	4,50



**Cala jamón hueso de vaca**

Ham piercer

*Cale jambon*

Ref.	Euros
A-27	19,00



**Cala jamón mango madera**

Ham piercer

*Cale jambon*

Ref.	Euros
A-28	17,50



**Cala jamones bolígrafo**

Ham piercer

*Cale jambon*

Ref.	Euros
A-29	18,50

**GANCHOS ACERO-INOX | STAINLESS STEEL HOOKS | CROCHETS ACIER-INOX**



**Ganchos acero-inox**

Stainless steel hooks

*Crochets acier-inox*

Ref.	Largo Long Longueur	Varilla Rod Tige	Unidades Units Unités	Euros
G-00	8 cm	4 mm	10	7,00
G-0	10 cm	4 mm	10	7,50
G-1	12 cm	5 mm	10	9,50
G-2	14 cm	5 mm	10	10,50
G-3	16 cm	5 mm	10	12,50
G-4	18 cm	5 mm	10	13,50

**Ganchos acero-inox**

Stainless steel hooks

*Crochets acier-inox*

Ref.	Largo Long Longueur	Varilla Rod Tige	Unidades Units Unités	Euros
G-5	20 cm	5 mm	10	16,50
G-6	22 cm	6 mm	10	19,00
G-7	20 cm	8 mm	10	33,00
G-8	30 cm	8 mm	10	46,50
G-9	18 cm	8 mm	10	31,00

**Ganchos giratorio acero-inox**

Stainless steel rotating hooks

*Giratoire crochets acier-inox*

Ref.	Largo Long Longueur	Varilla Rod Tige	Euros
G-10	25 cm	11 mm	25,00
G-11	30 cm	11 mm	26,50
G-12	25 cm	12 mm	13,50
G-13	30 cm	12 mm	15,50

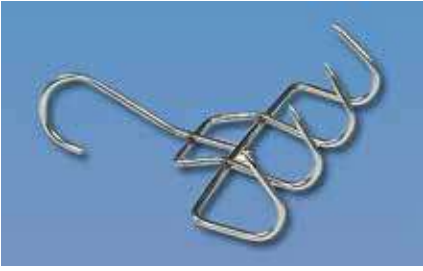

**Gancho 4 puntas**

4-spike hook

*Crochet 4 pointes*

Ref.	Euros
G-14	8,00



**Gancho de pared**

Wall hook

*Crochet mural*

Ref.	Medidas Size Dimensions	Euros
G-18	120 x 10	15,50
G-19	120 x 12	16,50



**Gancho salchichero giratorio de 22 cms de altura con 4 brazos de 10 cms.**

Revolving sausage hook of 22 cms height with 10 cms arms

*Crochet à saucisses giratoire de 22 cms d'hauteur avec 4 bras de 10 cms*

Ref.	Euros
G-15	39,50



**Torre pirámide salchichera**

Pyramid sausage tower

*Tour pyramide à saucisses*

Ref.	Altura Height Hauteur	Diámetro Diameter Diamètre	Euros
G-20	39 cm	Ø 28 cm	57,50



**Librador-cogedor, inox**

Stainless steel scoops

Pellesà main, inox

Ref.	Medidas Size Dimensions	Euros
A-5-12	21 / 12 x 6 cm	15,00
A-5-16	25 / 16 x 9 cm	16,50
A-5-20	29 / 18 x 10 cm	21,00
A-5-24	31 / 20 x 11 cm	25,50



**Librador - cogedor inyectado**

Plastic scoop

Pelle à main, plastique

Ref.	Medidas Size Dimensions	Euros
A-4-11	18 / 12 x 6 cm	2,70
A-4-14	24 / 16 x 8 cm	3,10
A-4-16	28 / 19 x 10 cm	3,70
A-4-20	33 / 22 x 11 cm	4,80
A-4-24	38 / 26 x 13 cm	5,80

**PINZAS, PORTA ROLLS, SOPORTE TICKETS | TONGS, ROLL HOLDERS, TICKET HOLDER | PINCES, PORTE ROLEAUX, SUPPORT TICKET**



**Pinza acero inox con muelle**

Stainless steel tong with spring

Pince acier inox avec ressort

Ref.	Euros
A-8	2,75



**Pinza acero inox. para embutido**

Stainless stel tong for cold meats

Pince acier inox pour charcuterie

Ref.	Euros
A-20	6,00



**Pinza acero inox espina pescado**

Stainless steel tong for fish bone

Pince acier inox arête poisson

Ref.	Euros
A-23	8,00



**Pinza acero inox**

Stainless steel tong

Pince acier inox

Ref.	Largo Long Longueur	Euros
A-24	24 cm	17,00



**Pinza acero-inox con anillas**

Stainless steel tong with rings

Pince acier inox avec anneaux

Ref.	Euros
A-26	13,00



**Porta-notas acer-inox, 60 cm con bolitas**

Stainless steel note holder 60 cm, little balls system

Porte-notes acier inox 60 cm, système boules

Ref.	Euros
T-360	29,00



**Soposte para pinchar tickets**

Ticket holder

*Support pour piquer les tickets*

Ref.	Euros
PR-25	13,00



**Porta rollo hilo**

Thread roll holder

*Porte rouleau fil*

Ref.	Euros
PR-20	106,00

**MÁQUINA MANUAL PINCHOS | MANUAL BROCHETTE MAKER | MACHINE MANUELLE POUR BROCHETTES**



**Máquina manual pinchos acero inox 2 unidades**

Stainless steel maual brochette maker 2 units

*Machine manuelle inox. pour brochettes 2 unités*

Ref.	Euros
A-49	380,00

**MOLDE BROCHETAS. PALILLOS | BROCHETTE MOLD. SKEEWERS | MOULE BROCHETTES. BROCHETTES**



**Molde brochetas polietileno para 25 unidades**

Brochette polyethylene mold 25 units

*Moule brochettes de polyéthylène*

Ref.	Medidas Size Dimensions	Euros
A-50	16,5 x 16,5 x 31 cm	146,00



**Palillos**

Skewers

*Brochette*

Ref.	Largo Long Longueur	Unidades Units Unités	Euros
A-50-15	15 cm	200	1,60
A-50-25	25 cm	100	1,70
A-50-30	30 cm	100	2,10



**Enternecedor carne minibla**

Meat tenderizer

*Attendrisseur manuel*

Ref.	Euros
A-15	66,00

**MALLA Y ANILLAS ELÁSTICAS | ELASTIC MESH AND RINGS | MAILLE ET ANNEAUX ÉLASTIQUES**



**Malla elástica. Máximo 175º**

Elastic mesh. Maximum 175º

*Maille élastique. Maximum 175º*

Ref.	Tipo Type	Largo Long Longueur	Euros
H-12SR	12	50 m	10,50
H-14SR	14	50 m	11,50
H-16SR	16	50 m	12,50
H-18SR	18	50 m	13,00
H-20SR	20	50 m	14,50

Ref.	Tipo Type	Largo Long Longueur	Euros
H-22R	22	50 m	21,00
H-24R	24	50 m	21,50
H-26R	26	50 m	23,00
H-28R	28	50 m	25,00



**Anillas elásticas**

Elastic rings

*Anneaux élastiques*

Ref.	Tipo Type	Peso Weight Poids	Euros
H-120NV	120	3 kg	87,00
H-140NV	140	3 kg	87,00

**TUBO PLÁSTICO | PLASTIC TUBE | TUBE EN PLASTIQUE**



**Tubo plastico naranja**

Orange plastic tube

*Orange tube en plastique*

Ref.	Tipo Type	Euros
H-E10	10/86	39,00
H-E12	12/92	39,00
H-E14	14/110	39,00
H-E16	16/125	41,00
H-E18	18/140	41,00







**Protector hueso**

Bone protector

Protecteur d'os

Ref.	Tipo Type Type	Largo Long Longueur	Euros
H-P23	23	100 m	70,00
H-P33	33	100 m	102,00

**Protector hueso pre-corte 7,5**

Precut 7,5 bone protector

Protecteur 7,5 hueso pre-corte

Ref.	Tipo Type Type	Largo Long Longueur	Euros
H-P23-C	23	100 m	70,00
H-P33-C	33	100 m	102,00

TERMOMETROS | THERMOMETERS | THERMOMÈTRES |



**Termómetro para Frigorífico o Congelador vertical (-50+50°)**

Vertical Thermometer for Refrigerator or Freezer (-50 + 50°)

Thermomètre vertical pour réfrigérateur ou congélateur (-50 + 50°)

Ref.	Euros
T-002	4,50



**Termómetro Digital Horno con Sonda (0-300°)**

Digital Thermometer Oven with Probe (0-300°)

Thermomètre numérique Four avec sonde (0-300°)

Ref.	Euros
T-003	64,50



**Termometro Asado con Pincho (+55+88°)**

Roast Thermometer with Pin (+55+88°)

Thermomètre Rôti avec Pique (+55+88°)

Ref.	Euros
T-005	19,00



**Termometro Aceite con Gancho (0-300°)**

Oil Thermometer with Hook (0-300°)

Thermomètre à huile avec crochet (0-300°)

Ref.	Euros
T-007	18,50



**Termómetro Digital para Frigorífico o Congelador con Sonda (-50-70°)**

Digital Thermometer for Refrigerator or Freezer with Probe (-50-70°)

Thermomètre numérique pour réfrigérateur ou congélateur avec sonde (-50-70°)

Ref.	Euros
T-009	30,00



**Termómetro Laser de bolsillo (-50+300°)**

Pocket-Size Laser Thermometer (-50 + 300°)

Thermomètre à laser de poche (-50 + 300°)

Ref.	Euros
T-012	80,00



**Termómetro laser modelo Extra (-50+280°)**

Laser thermometer Extra model (-50 + 280°)

Thermomètre laser modèle supplémentaire (-50 + 280°)

Ref.	Euros
T-008	99,00



**Termómetro Frigorífico (-50 +50°)**

Refrigerator Thermometer (-50 + 50°)

Thermomètre de réfrigérateur (-50 + 50°)

Ref.	Euros
T-050	15,00

**Testador de Aceite (Pack 10 und.)**

Oil Tester (Pack 10 units.)

Testeur d'huile (Pack 10 unités)

Ref.	Euros
TA-002	53,00



0

8

**Cierra bolsas - rollos, Etiquetadoras-rollos,  
Naveteadoras, Espejos vigilancia, Carro servicio  
- Bandejero, Cestos - carros autoservicio,  
Dispensadores bolsas, Carros Gastronorm.**

---

Bag-roll sealer, Labellers-rolls, Labelling gun,  
Vigilance mirror, Service trolley - tray, Self-service  
basket - trolley, Bags dispensers, Gastronorm  
trolley.

---

*Machines ferme sacs, Étiquetteuses-rolls,  
Pistolet à étiqueter, Miroir de surveillance, Chariot  
service - Plateau, Panier - chariot self-service,  
Dispensateurs sacs, Chariot Gastronorm.*

**149 - 160**



**Máquina cierra bolsas plástico blanco**

Bag sealer white plastic

*Machine pour fermer les sacs plastique blanc*

Ref.	Euros
CB-606	21,00



**Máquina cierra bolsas acero inox  
Con cuchilla para cortar bolsa**

Bag sealer stainless steel  
With bag cutter blade

*Machine pour fermer les sacs acier inox  
Avec lame pour couper le sac*

Ref.	Euros
CB-101	29,50



**Rollo de PVC 66 x 12**

PVC Rolls 66 x 12

*Rouleaux PVC 66 x 12*

Ref.	Color Colour Couleur	Unidades Units Unités	Euros
RB-4-B	○	24	58,00
RB-4-A	●	24	58,00
RB-4-AZ	●	24	58,00
RB-4-R	●	24	58,00
RB-4-V	●	24	58,00
RB-4-T	⊕	24	45,00



**Dispensador celo inyección para referencias RB-4**

Cello tape dispenser injection for references RB-4

*Distributeur scotch injection pour références RB-4*

Ref.	Euros
CB-800	10,00

**ETIQUETADORAS | LABELLERS | ÉTIQUETTEUSES**



**Etiquetadora una línea 8 dígitos**

Labeller 1 line 8 digits

*Étiquetteuse 1 ligne chiffres*

Ref.	Euros
E-4	93,00



**Etiquetadora una línea 6 dígitos**

Labeller 1 line 6 digits

*Étiquetteuse 1 ligne 6 chiffres*

Ref.	Euros
E-5	78,00



**Etiquetadora una línea 6 dígitos**

Labeller 1 line 6 digits

*Étiquetteuse 1 ligne 6 chiffres*

Ref.	Euros
E-5-ECO	51,00



**Etiquetadora dos líneas 8 dígitos**

Labeller 2 line 8 digits

Étiquetteuse 2 lignes 8 chiffres

Ref.	Euros
E-6	142,00



**Etiquetadora dos líneas 8 dígitos**

Labeller 2 line 8 digits

Étiquetteuse 2 ligne 8 chiffres

Ref.	Euros
E-6-ECO	92,00

**Rodillo tinta**

Ink roller

Rouleau encre

Ref.	Para For Pour	Euros
E-110	E-4, E-5, E-6	5,00

**Rodillo tinta**

Ink roller

Rouleau encre

Ref.	Para For Pour	Euros
E-110-ECO	E-5-ECO, E-6-ECO	5,00

**ROLLOS ETIQUETADORAS | LABELLERS | ÉTIQUETTEUSES**



**Rollos etiquetas**

Label rolls

Rouleaux d'etiquettes

Ref.	Medidas Size Dimensions	Color Colour Couleur	Tipo Type Type	Unidades Units Unités	Euros
RE-5-B	26 x 12 mm	○	1	8	9,50
RE-5-N	26 x 12 mm	●	1	8	14,50
RE-6-B	26 x 16 mm	○	2	8	9,50
RE-6-N	26 x 16 cm	●	2	8	14,50

**Rollo etiquetas dos líneas lote-caducidad**

Label rolls 2 lines expiry date

Labell rolls 2 lines date de péremtion

Ref.	Medidas Size Dimensions	Unidades Units Unités	Euros
RE-7	26 x 16 mm	8	10,50

**Rollos etiquetas dos líneas fecha envasado-fecha caducidad**

Label rolls 2 lines packaging date and expiry date

Rouleaux d'etiquettes 2 lignes date d'envasement et péremtion

Ref.	Medidas Size Dimensions	Unidades Units Unités	Euros
RE-8	26 x 16 mm	8	10,50





**Naveteadora Dennison homologada**

Labelling gun Dennison approved

*Pistolet à étiquetter Dennison homologué*

Ref.	Euros
N-3	58,00



**Navet cárnico standard 25 mm caja 10.000 unidades**

Standard meat tag 25 mm

*Étiquetteuse à viande standard 25 mm*

Ref.	Unidades Units Unités	Euros
N-21	10000	25,00



**Naveteadora Arrow standard**

Labelling gun Arrow standard

*Pistolet à étiquetter Arrow standard*

Ref.	Euros
N-9	21,00



**Naveteadora P.P. blanco caja 5.000 unidades**

White P.P. tag 40 mm

*Étiquetteuse P.P. blanc 40 mm*

Ref.	Unidades Units Unités	Euros
N-22	5000	10,00

**Navet cárnico homologado 25 mm caja 5000 unidades**

Approved meat tag 25 mm

*Étiquetteuse à viande homologuée 25 mm*

Ref.	Unidades Units Unités	Euros
N-20	5000	47,50

**Aguja Dennison standard 5 unidades**

Standard meat pin Dennison 5 units

*Aiguille à viande Dennison standard 5 unités*

Ref.	Unidades Units Unités	Euros
N-30	5	15,00

**Aguja Dennison homologada 5 unidades**

Standard meat pin Dennison 5 units

*Aiguille à viande Denisson standard 5 unités*

Ref.	Unidades Units Unités	Euros
N-31	5	58,00

**Aguja arrow standard 5 unidades**

Standard meat pin arrow 5 units

*Aiguille à viande arrow standard 5 unités*

Ref.	Unidades Units Unités	Euros
N-32	5	15,00





**Carro bandejero plegable**  
**Plegable: 10 guías. 2 ruedas giratorias. 2 ruedas giratorias con stop. Ruedas cincadas. Ideal para bandeja BI-15 ó cubeta CC-9/19/21**

Foldable tray trolley  
 Foldable: 10 rails. 2 swivel wheels. Wheels: zinc coated. Ideal for BI-15 tray or CC-9/19/21 deep tray

*Chariot à plateaux-bacs plian*  
 Pliant: 10 guides. 2 roulettes giratoires. 2 roulettes giratoires avec stop. Roulettes: zinguées. Idéal pour plateau BI-15 ou cuvette CC-9/19/21

Ref.	Medidas Size Dimensions	Color Colour Couleur	Euros
R-10-G	54 x 65 x 179 cm	●	807,00
R-10-BE	54 x 65 x 179 cm	○	807,00

**Carro bandejero plegable**  
**Plegable: 10 guías. 2 ruedas giratorias. 2 ruedas giratorias con stop. Ruedas poliamida. Ideal para bandeja BI-15 ó cubeta CC-9/19/21**

Foldable tray trolley  
 Foldable: 10 rails. 2 swivel wheels. Wheels: polyamide. Ideal for BI-15 tray or CC-9/19/21 deep tray

*Chariot à plateaux-bacs plian*  
 Pliant: 10 guides. 2 roulettes giratoires. 2 roulettes giratoires avec stop. Roulettes: polyamide. Idéal pour plateau BI-15 ou cuvette CC-9/19/21

Ref.	Medidas Size Dimensions	Color Colour Couleur	Euros
R-10-GP	54 x 65 x 179 cm	●	896,00
R-10-BEP	54 x 65 x 179 cm	○	896,00



**Carro bandejero inox Tipo 60 x 40**  
**20 guías. 2 ruedas giratorias. 2 ruedas giratorias con stop. Incluido ruedas. Embalaje desmontado. Ideal para bandeja BI-15**

Stainless steel tray trolley Type 60 x 40  
 20 rails. 2 swivel wheels. Wheels included. Packaged disassembled. Ideal for BI-15 tray

*Chariot à plateaux-bacs inox Type 60 x 40*  
 20 guides. 2 roulettes giratoires. 2 roulettes giratoires avec stop. Compris roulettes. Emballage démonté. Idéal pour plateau BI-15

Ref.	Medidas Size Dimensions	Euros
R-20	46,5 x 63 x 186 cm	420,00

**Carro bandejero inox 1/1**  
**20 guías. 2 ruedas giratorias. 2 ruedas giratorias con stop. Incluido ruedas. Embalaje desmontado. Ideal para bandeja BI-15**

Stainless steel tray trolley 1/1  
 20 rails. 2 swivel wheels. Wheels included. Packaged disassembled. Ideal for BI-15 tray

*Chariot à plateaux-bacs inox 1/1*  
 20 guides. 2 roulettes giratoires. 2 roulettes giratoires avec stop. Compris roulettes. Emballage démonté. Idéal pour plateau BI-15

Ref.	Medidas Size Dimensions	Euros
R-21	38 x 55 x 186 cm	431,00

**Carro bandejero inox 2/1**  
**20 guías. 2 ruedas giratorias. 2 ruedas giratorias con stop. Incluido ruedas. Embalaje desmontado.**

Stainless steel tray trolley 2/1  
 20 rails. 2 swivel wheels. Wheels included. Packaged disassembled.

*Chariot à plateaux-bacs inox 2/1*  
 20 guides. 2 roulettes giratoires. 2 roulettes giratoires avec stop. Compris roulettes. Emballage démonté.

Ref.	Medidas Size Dimensions	Euros
R-22	58,5 x 67,5 x 186 cm	458,00



**Bandejas ABS para carros R-10/R-20**

ABS tray

Plateau ABS



Ref.	Medidas Size Dimensions	Color Colour Couleur	Euros
BI-15-B	58,5 x 41 x 2,5 cm	○	19,00
BI-15-R	58,5 x 41 x 2,5 cm	●	20,00
BI-15-N	58,5 x 41 x 2,5 cm	●	20,00

**Bandejas Pasteleras Acero Inox. / Aluminio**

Stainless steel / aluminum pastry trays



Ref.	Medidas Size Dimensions	Euros
BAC-1	60 x 40 x 1 cm	55,00
BAL-1	60 x 40 x 1 cm	37,00



**Carro de servicio, acero-inox  
2 estanterías. Ruedas: 2 giratorias,  
2 giratorias con stop. Embalaje:  
desmontado. 40 kgs por estante**

Service trolley, stainless steel  
2 Shelves. 2 revolving wheels, 2 revolving  
wheels with brake. Package: disassembled.  
40 kg per shelf

*Chariot service, acier inox  
2 Étagères. Roulettes 2 giratoires, 2  
giratoires avec stop. Embalage: démonté.  
40 kilos par étagère*

Ref.	Medidas Size Dimensions	Euros
R-30	91 x 59 x 93 cm	260,00



**Carro de servicio, acero-inox  
3 estanterías. Ruedas: 2 giratorias,  
2 giratorias con stop. Embalaje:  
desmontado. 40 kgs por estante**

Service trolley, stainless steel  
3 Shelves. 2 revolving wheels, 2 revolving  
wheels with brake. Package: disassembled  
40 kg per shelf

*Chariot service, acier inox  
3 Étagères. Roulettes 2 giratoires, 2  
giratoires avec stop. Embalage: démonté  
40 kilos par étagère*

Ref.	Medidas Size Dimensions	Euros
R-31	91 x 59 x 93 cm	298,00



**Cesto un asa**  
Alta resistencia. Opciones: logotipos y/o otros colores : min. 720 unidades.

1-handle basket  
High resistance. Options: logotypes and/or other colours: min 720 units

*Panier 1 anses*  
Haute resistance. Optionnel: logotypes et/ou autres couleurs: min 720 unités

Ref.	Medidas Size Dimensions	Capacidad Capacity Capacité	Color Colour Couleur	Euros
R-2020-AZ	47 x 31 x 30 cm	28	●	15,00
R-2020-R	47 x 31 x 30 cm	28	●	15,00
R-2020-V	47 x 31 x 30 cm	28	●	15,00
R-2021	<b>Carrito para apilar y mover R-2020</b> Piling and transport kart R-2020 <i>Chariot pour empiler et déplacer R-2020</i>			71,50



**Cesto con 4 ruedas 2 fijas 2 giratorias**  
Asas abatibles

4-wheel basket with 2 fixed and 2 revolving wheels  
Collapsible handles

*Panier avec 4 roulettes 2 fixes 2 giratoires*  
*Anses rabattables*

Ref.	Medidas Size Dimensions	Color Colour Couleur	Capacidad Capacity Capacité	Euros
R-2032-AZ	50 x 34 x 36 cm	●	32 l	36,00
R-2032-R	50 x 34 x 36 cm	●	32 l	36,00
R-2032-V	50 x 34 x 36 cm	●	32 l	36,00



**Cesto con 4 ruedas 2 fijas 2 giratorias**  
Asas abatibles

4-wheel basket with 2 fixed and 2 revolving wheels  
Collapsible handles

*Panier avec 4 roulettes 2 fixes*  
*2 giratoires*

Ref.	Medidas Size Dimensions	Color Colour Couleur	Capacidad Capacity Capacité	Euros
R-2054-AZ	55 x 39,5 x 44 cm	●	54 l	44,50
R-2054-R	55 x 39,5 x 44 cm	●	54 l	44,50
R-2054-V	55 x 39,5 x 44 cm	●	54 l	44,50



**Cadena inicio**

Start chain

Chaîne démarrage

Ref.	Euros
R-CI110	48,50

**Porta-monedas**

Coin box

Porte monnaie

Ref.	Euros
R-PM110	51,50

**Carro autoservicio 80 l**

80 l self-service trolley

Chariot self-service 80 l

Ref.	Medidas Size Dimensions	Capacidad Capacity Capacité	Euros
R-80	63 x 49,5 x 105 cm	80 l	231,00



**Carro autoservicio 50 l**

50 l self-service trolley

Chariot self-service 50 l

Ref.	Medidas Size Dimensions	Euros
R-50	57 x 47 x 91,5 cm	175,00



**Carro autoservicio 75 l**

75 l self-service trolley

*Chariot self-service 75 l*

Ref.	Medidas Size Dimensions	Euros
R-75	78 x 51 x 87,6 cm	222,00



**Cadena inicio**

Start chain

*Chaîne démarrage*

Ref.	Euros
R-CI	41,00



**Carro autoservicio 100 l**

100 l self-service trolley

*Chariot self-service 100 l*

Ref.	Medidas Size Dimensions	Euros
R-100	85,5 x 51,5 x 101 cm	244,00

**Porta-monedas**

Coin box

*Porte monnaie*

Ref.	Euros
R-PM	67,50



**Dispensador con precorte para bolsas en rollo bio anchura 23 cm**

Pre-cut dispenser for bio roll bags width 23 cm

*Distributeur prédécoupé pour sacs bio roll largeur 23 cm*

Ref.	Euros
MR-109-N	102,00

**Soporte fijación pie 102 cm**

Foot fixing support 102 cm

*Support de fixation pied 102 cm*

Ref.	Euros
MR-108-N	90,00



**Soporte para bolsas de bloque**

Bag roll block holder

*Support pour sacs en bloc*

Ref.	Euros
MR-110	25,00



**Soporte fijación pared**

Wall fixing bracket

*Support de fixation murale*

Ref.	Euros
MR-107-N	62,00



#### Dispensador porta guantes inox

Stainless steel glove dispenser for ref. W-12

*Dispensateur porte-gants inox pour réf. W-12*

Ref.	Euros
MR-104-I	84,00

#### Dispensador para bolsas en rollo de 500 unidades

Bag roll dispenser for MR-500 bags

*Dispensateur pour sacs en rouleau réf. MR-500*

Ref.	Euros
MR-103-I	90,00

#### Soporte de fijación inox. para réf. MR-103-I/104-I

Stainless steel support stand for ref MR-103-I/104-I

*Support de fixation inox pour réf. MR-103-I/104-I*

Ref.	Euros
MR-105-I	125,00

#### Dispensador inox 2 brazos para rollo bolsas

Stainless steel dispenser 2 arms for bags roller

*Dispensateur acier inox 2 bras pour rouleau sacs*

Ref.	Euros
MR-119-I	57,00



#### Soporte para bolsas de bloque acero inox

Support for stainless steel block bags

*Support pour sacs de bloc acier inox*

Ref.	Euros
MR-115-I	42,00

0

9

**Cuchillería profesional, Afiladores, Chairas, Hachas, Tijeras, Espátulas, Bacaladera, Abre-Ostras, Sierras, Imanes, Guillotinas queso, Sacacorchos, Abrelatas, Guantes, Delantes, Material de un uso, Delantales protección, Guantes frío, Guantes malla acero-inox, Guantes y manoplas calor.**

---

Professional knives, Sharpeners, Axes, Scissors, Spatulas, Fish shears, Oyster sucker, Saws, Magnets, Cheese guillotines, Corkscrew, Can openers, Gloves, Aprons, Disposable material, Protective aprons, Cold gloves, Mesh steel-stainless gloves, Gloves and mittens heat.

---

*Couteaux professionnels, Aiguiseurs, Scies, Ciseaux, Spatules, Moorutiel manuel, Couteau à huitres, Scies, Aimants, Guillotines à fromage, Tire-Bouchon, Ouvre-Boîtes, Gants, Tabliers, Material d'un seul usage, Tabliers de protection, Gants froid, Gants en acier inoxydable, Gants et mitaines chaleur.*



**Cuchillo carnicero alveolado**  
**Mango inyectado**

Indented butcher's knife  
Plastic handle

*Couteau de boucher alvéolé*  
*Manche en plastique*

Ref.	Largo Long Longueur	Color Colour Couleur	Euros
0151.310	310 mm	● ● ● ● ●	33,00
0151.355	355 mm	● ● ● ● ●	41,00
0151.395	395 mm	● ● ● ● ●	49,00



**Cuchillo carnicero**  
**Mango inyectado**

Butcher's knife  
Plastic handle

*Couteau de boucher*  
*Manche en plastique*

Ref.	Largo Long Longueur	Color Colour Couleur	Euros
0170.155	155 mm	● ● ● ● ●	12,00
0170.185	185 mm	● ● ● ● ●	13,50
0170.210	210 mm	● ● ● ● ●	15,50
0170.260	260 mm	● ● ● ● ●	19,50
0170.310	310 mm	● ● ● ● ●	24,00
0170.355	355 mm	● ● ● ● ●	28,50
0170.395	395 mm	●	36,00



**Cuchillo degollar**  
**Mango inyectado**

Sticking knife  
Plastic handle

*Couteau à égorger*  
*Manche en plastique*

Ref.	Largo Long Longueur	Color Colour Couleur	Euros
0370.165	165 mm	●	16,00
0370.195	195 mm	●	18,00
0370.225	225 mm	●	19,50



**Cuchillo deshuesar**  
**Mango inyectado**

Boning knife  
Plastic handle

*Couteau à désosser*  
*Manche en plastique*

Ref.	Largo Long Longueur	Color Colour Couleur	Euros
0425.130	130 mm	● ● ● ● ●	11,00
0425.150	150 mm	● ● ● ● ●	12,00





**Cuchillo deshuesar, hoja curva**  
**Mango inyectado**

Boning knife, curve blade  
Plastic handle

*Couteau à désosser, lame courbe*  
*Manche en plastique*

Ref.	Largo Long Longueur	Color Colour Couleur	Euros
0430.150	150 cm	●●●●●	14,00



**Cuchillo pescadero**  
**Mango inyectado**

Fish knife  
Plastic handle

*Couteau à poisson*  
*Manche en plastique*

Ref.	Largo Long Longueur	Color Colour Couleur	Euros
0701.320	320 mm	●●●●●	45,00
0701.350	350 mm	●●●●●	49,00
0701.370	370 mm	●●●●●	53,00



**Cuchillo pescadero**  
**L/vaca M/polietileno**

Fish knife  
Polyethylene handle

*Couteau à poisson*  
*Manche polyéthylène*

Ref.	Largo Long Longueur	Color Colour Couleur	Euros
0720.350	350 mm	●	60,00
0720.380	380 mm	●	65,00



**Cortante bacalao**  
**Mango polietileno**

Cod knife  
Polyethylene handle

*Couteau à morue*  
*Manche polyéthylène*

Ref.	Largo Long Longueur	Color Colour Couleur	Euros
0775.190	190 mm	●	48,00



**Cuchillo jamonero**  
**Mango polietileno. Hoja flexible**

Ham knife  
Polyethylene handle. Flexible blade

*Couteau pour jambon*  
*Manche polyéthylène. Lame flexible*

Ref.	Largo Long Longueur	Color Colour Couleur	Euros
0500.305	305 mm	●	14,00



**Cuchillo jamón**  
**Mango inyectado**

Ham knife  
Plastic handle

*Couteau pour jambon*  
*Manche en plastique*

Ref.	Largo Long Longueur	Color Colour Couleur	Euros
0526.250	250 mm	●	12,00
0526.300	300 mm	●	14,00



**Cuchillo jamón**  
**Hoja estrecha, mango polietileno**

Ham knife  
Narrow blade, polythylene handle

*Couteau jambon*  
*Lame étroite, manche polyéthylène*

Ref.	Largo Long Longueur	Color Colour Couleur	Euros
0540.250	250 mm	●	13,50
0540.305	305 mm	●	14,50

**Cuchillo jamonero  
Mango polietileno. Hoja recia.**

Ham knife  
Polyethylene handle. Hard blade

*Couteau pour jambon  
Manche polyéthylène. Lame dure*

Ref.	Largo Long Longueur	Color Colour Couleur	Euros
0521.250	250 mm	●	18,00

**Cuchillo jamonero  
Mango polietileno. Hoja recia.**

Ham knife  
Polyethylene handle. Hard blade

*Couteau pour jambon  
Manche polyéthylène. Lame dure*

Ref.	Largo Long Longueur	Color Colour Couleur	Euros
0521.300	300 mm	●	19,50



**Cuchillo cocinero forjado  
Mango phenolkraff**

Forged chef's knife  
Phenolkraff handle

*Couteau de cuisine forgé  
Manche phenolkraff*

Ref.	Largo Long Longueur	Color Colour Couleur	Euros
4000.100	100 mm	●●●●●	19,50
4000.150	150 mm	●●●●●	29,00
4000.200	200 mm	●●●●●	40,50
4000.250	250 mm	●●●●●	49,00
4000.300	300 mm	●●●●●	64,00

**Cuchillo deshuesar  
Mango phenoldraff**

Boning knife  
Phenoldraff handle

*Couteau désosser  
Manche phenolkraff*

Ref.	Largo Long Longueur	Color Colour Couleur	Euros
4010.150	150 mm	●●●●●	28,00

**Cuchillo jamonero  
Mango phenolkraff**

Ham knife  
Phenolkraff handle

*Couteau à désosser  
Manche phenolkraff*

Ref.	Largo Long Longueur	Color Colour Couleur	Euros
4020.300	300 mm	●●●●●	39,50

**Trinchante cocinero  
Mango phenolkraff**

Carving knife  
Phenolkraff handle

*Couteau à découper  
Manche phenolkraff*

Ref.	Largo Long Longueur	Color Colour Couleur	Euros
4050.180	180 mm	●●●●●	34,00



**Cuchillo Jamonero Mango Pom Alveolado**

Ham indented knife handle pom

*Couteau pour jambon alvéolé manche pom*

Ref.	Largo Long Longueur	Color Colour Couleur	Euros
4120.250	250 mm	●	25,00
4120.300	300 mm	●	29,00



**Cuchillo chef mango pom**

Chef knife handle pom

*Couteau de chef manche pom*

Ref.	Largo Long Longueur	Color Colour Couleur	Euros
4100.250	250 mm	●	26,00



**Cuchillo chef mango pom**

Chef knife handle pom

*Couteau de chef manche pom*

Ref.	Largo Long Longueur	Color Colour Couleur	Euros
4100.200	200 mm	●	19,50



**Cuchillo chef mango pom**

Chef knife handle pom

*Couteau de chef manche pom*

Ref.	Largo Long Longueur	Color Colour Couleur	Euros
4100.150	150 mm	●	14,00



**Cuchillo chef Santoku mango pom**

Chef knife Santoku handle pom

*Couteau de chef Santoku manche pom*

Ref.	Largo Long Longueur	Color Colour Couleur	Euros
4105.180	180 mm	●	25,00



**Cuchillo chef mango pom alveolado**

Chef knife handle pom indented

*Couteau de chef manche pom alvéolé*

Ref.	Largo Long Longueur	Color Colour Couleur	Euros
4101.250	250 mm	●	31,00



**Cuchillo chef para pan mango pom**

Chef knife for bread handle pom

*Couteau de chef pour pain manche pom*

Ref.	Largo Long Longueur	Color Colour Couleur	Euros
4102.230	230 mm	●	17,00



**Cuchillo Punta Aguda Mango Inyectado Anatomico y Antideslizante**

Sharp Point Knife with Anatomical Injected Handle and Anti-Slip

*Couteau à pointe fine avec manche injecté anatomique et antidérapant*

Ref.	Largo Long Longueur	Color Colour Couleur	Euros
4200.150	150 mm	●●●●	12,50
4200.200	200 mm	●●●●	17,00
4200.250	250 mm	●●●●	22,50
4200.280	280 mm	●●●●	25,00



**Cuchillo cocinero media luna**

Half moon chef knife

*Couteau de cuisine demi-lune*

Ref.	Largo Long Longueur	Color Colour Couleur	Euros
4300.270	270 mm	●	42,00



**Cuchillo de Golpe Mango Rallado Polipropileno**

Hitting knife Polypropylene Grated Handle

*Couteau à frapper Polypropylène Poignée Râpée*

Ref.	Medidas Size Dimensions	Color Colour Couleur	Euros
0600.300	85 x 300 mm	●	42,50
0600.350	95 x 300 mm	●	56,00



**Cuchillo cortante tallant**  
**Mango inyectado**

Cleaver knife  
Plastic handle

*Couperets*  
*Manche en plastique*

Ref.	Largo Long Longueur	Color Colour Couleur	Euros
0801.230	230 mm	● ● ● ● ●	40,00
0801.250	250 mm	● ● ● ● ●	49,00
0801.290	290 mm	● ● ● ● ●	62,00



**Cuchillo cortante tallant**  
**Cuchillo carnicero M/polietileno**

Cleaver knife  
Polyethylene handle

*Couperets*  
*Manche polyéthylène*

Ref.	Largo Long Longueur	Peso Weight Poids	Color Colour Couleur	Euros
0820.240	240 mm	1000 gr	●	65,00
0820.260	260 mm	1200 gr	●	73,00



**Cortante partir**  
**Mango polietileno**

Cleaver knife  
Polyethylene handle

*Couperet*  
*Manche polyéthylène*

Ref.	Largo Long Longueur	Color Colour Couleur	Euros
0840.320	320 mm	●	49,00



**Cuchillo cortante tallant**  
**Cuchillo carnicero M/inox**

Cleaver knife  
Stainless steel handle

*Couperets*  
*Manche inox*

Ref.	Largo Long Longueur	Peso Weight Poids	Euros
0850.220	220 mm	1250 gr	107,00
0850.250	250 mm	1500 gr	127,00



**Cuchillo filetero  
Mango inyectado**

Fillet knife  
Plastic handle

*Couteau à fileter  
Manche en plastique*

Ref.	Largo Long Longueur	Color Colour Couleur	Euros
0901.290	290 mm	●●●●●	42,00
0901.310	310 mm	●●●●●	47,00



**Cuchillo chuletero  
Mango inyectado**

Chopping knife  
Plastic handle

*Couteau à côtelettes  
Manche en plastique*

Ref.	Largo Long Longueur	Color Colour Couleur	Euros
0905.290	290 mm	●●●●●	45,00
0905.310	310 mm	●●●●●	50,00



**Cuchillo queso  
1 mango acodado con alveolos. Mango Phenolkruff**

Cheese knife  
Phenolkruff handle

*Couteau à fromage  
Manche Phenolkruff*

Ref.	Largo Long Longueur	Color Colour Couleur	Euros
1000.305	305 mm	●	47,00

**Cuchillo queso  
2 mangos acodado. Mango polietileno**

Cheese knife  
2 polyethylene handles

*Couteau à fromage  
2 manches en polyéthylène*

Ref.	Largo Long Longueur	Color Colour Couleur	Euros
1001.320	320 mm	●	49,00

**Cuchillo queso  
2 mangos polietileno**

Cheese knife  
2 polyethylene handle

*Couteau à fromage  
2 manches en poléthylène*

Ref.	Largo Long Longueur	Color Colour Couleur	Euros
1001.260	260 mm	●	29,00
1001.290	290 mm	●	35,00



**Cuchillo queso curvado**

Cheese curved knife

*Fromage courbé couteau*

Ref.	Largo Long Longueur	Color Colour Couleur	Euros
1000.450	45 cm	●	55,00



**Cuchillo queso  
Sierra mango phenolkruff**

Cheese knife  
Saw phenolkruff handle

*Couteau à fromage  
Scie manche en phenolkruff*

Ref.	Largo Long Longueur	Color Colour Couleur	Euros
2002.250	250 mm	●	21,50
2002.310	310 mm	●	23,50



**Cuchillo charcutero salmón  
Alveolado estrecho, mango polietileno**

Salmon charcuterie knife  
Narrow indented, polythylene handle

*Couteau à Saumon  
Alvólé étroite, manche polyéthylène*

Ref.	Largo Long Longueur	Color Colour Couleur	Euros
0560.250	250 mm	●	22,50
0560.310	310 mm	●	24,50



**Cuchillo charcutero-pastelero  
Mango polietileno**

Carving-pastry knife  
polyethylene handle

*Couteau de charcutier-pâtisser  
Manche polyéthylène*

Ref.	Largo Long Longueur	Color Colour Couleur	Euros
0575.250	250 mm	●	22,50
0575.300	300 mm	●	29,00
0575.360	360 mm	●	37,50



**Aplasta filetes  
Acero inox.**

Steak pounder  
Stainless steel.

*Pelle pour aplatir les filets  
Acier inox.*

Ref.	Peso Weight Poids	Euros
1705.150	1,5 kg	40,00



**Gubia de bola m/polietileno blanco**

Ball gouge m / polyethylene white ball

*Gouge à bille m / bille blanche en  
polyéthylène*

Ref.	Largo Long Longueur	Color Colour Couleur	Euros
2401.260	260 mm	○	42,00



**Aplasta filetes inox**

Steak pounder

*Pelle pour aplatir les filets*

Ref.	Medidas Size Dimensions	Euros
1701.135	23 x 11 cm	33,00



**Gubia recta**

Gouge

*Gouge*

Ref.	Largo Long Longueur	Euros
2401.230	230 mm	31,00



**Escamador pescado profesional**

Professional fish scaller

*Écailleur à poisson professionnel*

Ref.	Largo Long Longueur	Euros
2526.000	25 cm	17,00



**Cuchillo puntilla  
Mango Penolkraff**

Pointed knife

*Couteau pointu*

Ref.	Largo Long Longueur	Euros
0010.100	100 mm	6,00



**Cuchillo serie clásica puntilla  
curva mango pom**

Classic series knife curved sprig  
handle pom

*Série Classic couteau courbe  
branche manche pom*

Ref.	Largo Long Longueur	Color Colour Couleur	Euros
0015.065	65 mm	●	6,00



**Afilador manual sobremesa**

Table manual knife sharpener

*Aigiseur manuel de table*

Ref.	Euros
F-40	19,00



**Juego varillas diamante para ref. F-35**

Set of rods for ref. F-35

*Lot de tiges pour réf. F-35*

Ref.	Euros
F-36	46,00



**Afilador manual diamante**

Manual diamond knife sharpener

*Aigiseur manuel diamant*

Ref.	Euros
F-35	110,00

**CHAIRAS PROFESIONAL | PROFESSIONAL SHARPENERS | FUSILS PROFESSIONNELS**



**Chairas profesional redonda**

Professional sharpeners round

*Fusils professionnels, rond*

Ref.	Largo Long Longueur	Euros
3000.200	20 cm	9,00
3000.250	25 cm	19,00
3000.300	30 cm	20,50

**Profesional oval 30**

Professional Oval

*Profesional Rond*

Ref.	Largo Long Longueur	Euros
3050.300	30 cm	36,00



**Profesional redonda cruzeta inox 30 cm**

Round 30 cm

*Rond 30 cm*

Ref.	Largo Long Longueur	Euros
3100.300	30 cm	41,50

**Profesional oval cruzeta inox**

Oval

*Ovale*

Ref.	Largo Long Longueur	Euros
3150.300	30 cm	53,00



### Professional redonda

Round

*Rond*

Ref.	Largo Long Longueur	Color Couleur Couleur	Euros
3200.300-N	30 cm	●	36,00
3200.300-AZ	30 cm	●	36,00
3200.300-A	30 cm	●	36,00
3200.300-R	30 cm	●	36,00
3200.300-V	30 cm	●	36,00



### Oval profesional

Oval

*Ovale*

Ref.	Largo Long Longueur	Color Couleur Couleur	Euros
3250.300-N	30 cm	●	51,00
3250.300-AZ	30 cm	●	51,00
3250.300-A	30 cm	●	51,00
3250.300-R	30 cm	●	51,00
3250.300-V	30 cm	●	51,00



### Professional oval acero inoxidable

Oval stainless steel

*Ovale acier inox*

Ref.	Largo Long Longueur	Color Couleur Couleur	Euros
3400.300	30 cm	●	107,00



### Lujo extra plana

Extra plane luxe

*Luxe extra plat*

Ref.	Largo Long Longueur	Color Couleur Couleur	Euros
3500.300	30 cm	●	103,00





**Funda inyección para 4 cuchillos**

Injection knife holder for 4 knives

*Étui injection pour 4 couteaux*

Ref.	Euros
F-10	41,00

**Cinturón para funda inyección**

Belt for réf. F-10

*Ceinture pour réf. F-10*

Ref.	Euros
F-11	20,00



**Pincha salchichas 6 pinchos  
Mango plástico, acero inox**

Sausage poker 6-spikes  
Plastic handle, stainless steel

*Pique saucisses 6 brochettes  
Manche plastique, acier inox*

Ref.	Euros
F-12	9,00



**Pincha salchichas redondo 16  
pinchos inox**

Sausage poker 16-spikes  
stainless steel. Plastic handle.

*Pique saucisses 16 brochettes  
inox. Manche plastique.*

Ref.	Euros
F-17	8,00



**Aguja de mechar**

Stuffing needle

*Aiguille à farcir*

Ref.	Largo Long Longueur	Euros
F-13	30 cm	38,50



**Aguja para hilo**

Thread needle

*Aiguille pour fil*

Ref.	Largo Long Longueur	Euros
F-14	30 cm	25,50

**PIEDRAS AFILAR - AFILADOR MANUAL | WHETSTONES - MANUAL SHARPENER | PIERRES À AIGUISER - AIGUISEUR MANUEL**

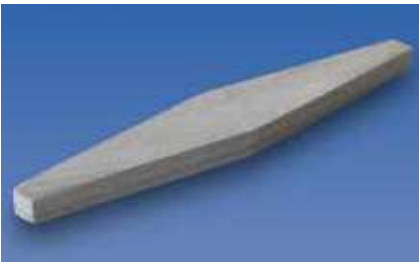

**Piedra de afilar natural. Grano negro.  
Rombo**

Natural whetstone. Medium grain. Diamond shape

*Pierre à aiguiser naturelle. Grain moyen.  
Losange.*

Ref.	Largo Long Longueur	Euros
3900.700	23 cm	11,00



**Piedra de afilar corindón. Grano grueso.  
Oval**

Natural whetstone. Rough grain. oval size

*Pierre à aiguiser naturelle gros grain. Ovale*

Ref.	Largo Long Longueur	Euros
3900.750	24 cm	10,00

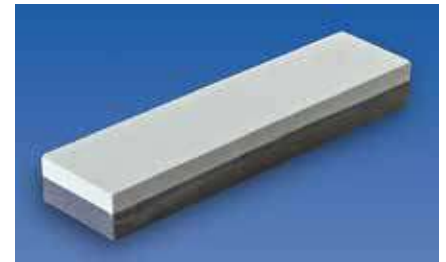

**Piedra de afilar silicic, 1 cara grano fino y  
1 cara grano grueso**

Silicic whetstone 1 side rough grain, 1 side fine grain

*Pierre à aiguiser silicate, 1 face gros grain,  
1 face grain fin*

Ref.	Medidas Size Dimensions	Euros
3900.995	20 x 5 x 2 cm	36,00



**Hacha de cámara**  
Mango polietileno

Axe

Scie

Ref.	Euros
A-6	143,00



**Hacha de corte, 1kg**  
Mango polietileno

Axe, 1kg

Scie, 1kg

Ref.	Euros
A-16	117,00

TIJERAS MANUALES | MANUAL SCISSORS | CISEAUX MANUEL



**Tijera pollero**

Poultry scissors

Ciseaux volaille

Ref.	Largo Long Longueur	Euros
TP-210	21 cm	48,50
TP-230	23 cm	59,00
TP-250	25 cm	62,50



**Tijera cocina-pescado**  
Con Tornillo

Kitchen-fish scissors

Ciseaux cuisine-poisson

Ref.	Largo Long Longueur	Euros
TC-180	18 cm	16,00
TC-200	20 cm	17,00
TC-220	22 cm	22,00
TC-240	24 cm	40,00
TC-280	28 cm	49,50



**Tijera forjada**

Forged scissors

Ciseaux forgés

Ref.	Largo Long Longueur	Euros
TF-200	20 cm	27,00
TF-225	22,5 cm	29,00



**Tijera trinchar**

Kitchen scissors

Ciseaux à découper

Ref.	Largo Long Longueur	Euros
TT-265	26,5 cm	20,50



**Espátula plancha**

Spatula

*Spatule*

Ref.	Largo Long Longueur	Euros
A-21	9 cm	13,50



**Espátula pastelero**

Spatula

*Spatule*

Ref.	Largo Long Longueur	Euros
A-51	20 cm	14,00



**Espátula pastelero**

Spatula

*Spatule*

Ref.	Largo Long Longueur	Euros
A-52	25 cm	19,50



**Paleta charcutería**

Spatula

*Spatule*

Ref.	Medidas Size Dimensions	Euros
A-14	12 x 6 cm	13,00



**Paleta acodada**

Spatula

*Spatule*

Ref.	Medidas Size Dimensions	Euros
A-22	15 x 8 cm	17,50



**Paleta besugo ancha**

Spatula

*Spatule*

Ref.	Medidas Size Dimensions	Euros
A-53	16 x 19 cm	26,50



**Paleta besugo larga**

Spatula

*Spatule*

Ref.	Medidas Size Dimensions	Euros
A-54	25 x 8 cm	24,50

**BACALADERA - TIJERAS MOSTRADOR | MANUAL FISH SHEARS - COUNTER SCISSORS | MORUTIEL MANUEL - CISEAUX COMPTOIR**



**Bacaladera manual  
Base polietileno**

Manual fish shears  
Polyethylene base

*Morutiel manuel  
Base polyéthylène*

Ref.	Euros
A-25	129,00



**Tijera mostrador con soporte inox  
Mango polietileno**

Counter scissors with stainless steel  
Polyethylene handel

*Ciseaux comptoir avec support inox  
Manche polyéthylène*

Ref.	Largo Long Longueur	Euros
TM-430	43 cm	200,00
TM-500	50 cm	235,00



**Abre-ostras acero-inox con protector**

Stainless steel oyster sucker  
*Couteau à huitres inox*

Ref.	Euros
A-2	4,50



**Rasqueta multiservicio**

Multipurpose scarpener  
*Raclette multiservice*

Ref.	Medidas Size Dimensions	Euros
A-18	15 x 12 cm	13,00



**Abre-ostras industrial**

Industrial oyster sucker  
*Couteau à huitres industrial*

Ref.	Euros
A-56	127,00

SIERRAS | SAWS | SCIÉS



**Sierra huesos  
Inox, Mango negro**

Bones saw  
 Stainless steel, black handle  
*Scie à os  
 Inox, anche noir*

Ref.	Largo Long Longueur	Euros
2460.400	40 cm	54,00
2460.450	45 cm	57,00
2460.500	50 cm	59,00

**Hoja recambio sierra inox**

Spare blade  
*Lame de rechange pour*

Ref.	Largo Long Longueur	Euros
2476.420	40 cm	8,50
2476.450	45 cm	9,00
2476.500	50 cm	9,50

IMANES | MAGNETS | AIMANTS

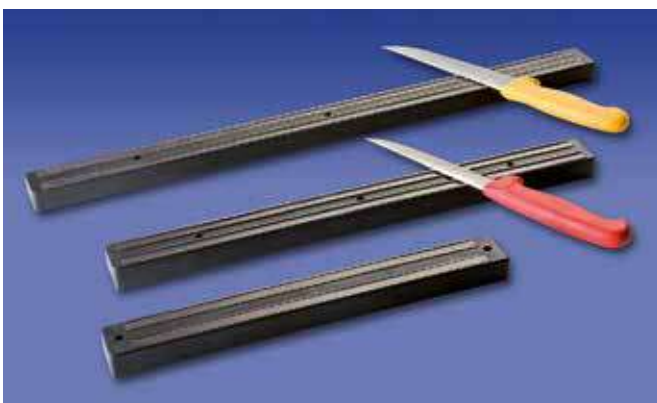

**Imanes**

Magnets  
*Aimants*

Ref.	Largo Long Longueur	Euros
2500.330	33 cm	15,50
2500.450	45 cm	18,50
2500.600	60 cm	23,00



**Guillotina queso blando**  
**Base polietileno**

Guillotine for slicing soft cheese  
Polyethylene base

*Guillotine pour découper le fromage à pâte*  
*Base en polyéthylène*

Ref.	Euros
F-20	155,00

**Recambio guillotina ref. F-20**  
**Pack 10 unidades**

Spare lyre for ref. F-20  
Pack 10 units

*Fil pour réf. F-20*  
*Pack 10 unités*

Ref.	Unidades Units Unités	Euros
F-21	10	10,00



**Lira queso blando de 21 cm**

Lyre arch for slicing soft cheese

*Arc lyre pour découper le fromage à pâte*

Ref.	Euros
F-15	14,50

**Recambio lira Ref. F-15**  
**Pack 10 unidades**

Spare lyre for ref. F-15  
Pack 10 units

*Fil pour réf. F-15*  
*Pack 10 unités*

Ref.	Unidades Units Unités	Euros
F-16	10	9,00



**Rizador queso**  
**Base madera 22 cm diametro**

Cheese curling  
Wood base 22 cm diameter

*Fraiseur de fromage*  
*Base de bois 22 cm diamètre*

Ref.	Euros
F-22	29,00

ABRELATAS Y SACACORCHOS | CAN OPENERS - CORKSCREW | OUVRE-BOÎTES - TIRE-BOUCHON



**Sacacorchos cromado pared**

Chrome wall corkscrew

*Tire-bouchon chromé mur*

Ref.	Euros
A-65	253,00



**Abrelatas industrial inox**

Stainless steel industrial can opener

*Ouvre-boîtes inox industriel*

Ref.	Euros
A-70	130,00



**Guantes 5 dedos inox banda plástico reversibles**

Finger reversible stainless steel gloves plastic band

*Gants 5 doigts inox bande plastique réversibles*

Ref.	Color Colour Couleur	Tipo Type Type	Euros
A-1050-X	●	XXS	94,00
A-1051-X	●	XS	94,00
A-1052-X	○	S	94,00
A-1053-X	●	M	94,00
A-1054-X	●	L	94,00
A-1055-X	●	XL	94,00



**Sujeción de plástico para guantes inox**

Plastic strap for stainless steel gloves

*Fixation en plastique pour gants inox*

Ref.	Unidades Units Unités	Euros
A-1001	100	60,00



**Guantes 5 dedos inox banda plástico reversibles CHAINEX**

5-finger reversibles stainless steel gloves plastic band CHAINEX

*Gants 5 doigts inox bande plastique réversibles CHAINEX*

Ref.	Color Colour Couleur	Tipo Type Type	Euros
A-1050	●	XXS	118,00
A-1051	●	XS	118,00
A-1052	○	S	118,00
A-1053	●	M	118,00
A-1054	●	L	118,00
A-1055	●	XL	118,00

**GUANTES ACERO-INOX CON MANGUITO | STAINLESS STEEL GLOVES WITH SLEEVE | GANTS ACIER INOX AVEC MANCHETTE**



**Guantes 5 dedos inox banda nylon con manguito policarbonato CHAINEX**

5-finger stainless steel gloves with polycarbonate sleeve CHAINEX

*Gants 5 doigts inox bande nylon avec manchette polycarbonate CHAINEX*

Ref.	Color Colour Couleur	Tipo Type Type	Euros
A-1020	●	XXS	280,00
A-1021	●	XS	280,00
A-1022	○	S	280,00
A-1023	●	M	280,00
A-1024	●	L	280,00



**Guantes 5 dedos inox banda nylon con manguito inox 16.5 cm reversible CHAINEX**

5-finger stainless steel gloves nylon band with reversible 16.5 cm stainless steel sleeve CHAINEX

*Gants 5 doigts inox bande nylon avec manchette inox 16.5 cm réversible CHAINEX*

Ref.	Color Colour Couleur	Tipo Type Type	Euros
A-1110	●	XXS	296,00
A-1111	●	XS	296,00
A-1112	○	S	296,00
A-1113	●	M	296,00
A-1114	●	L	296,00
A-1115	●	XL	296,00



**Manguito plástico de 14 cm**

Plastic sleeve 14 cm

*Manchette plastique 14 cm*

Ref.	Largo Long Longueur	Euros
A-1000	14 cm	35,00



**Guantes protección textil, 2 un. Talla pequeña. Banda de color blanco.**

Textile cut-protection gloves. Size S. Band of white color.

*Gants anti coupures textile. Taille S. Bande de couleur blanche.*

Ref.	Tipo Type Type	Euros
A-2001	S 7	20,00



**Guantes protección textil, 2 un. Talla mediana. Banda de color rojo.**

Textile cut-protection gloves. Size M. Band of red color.

*Gants anti coupures textile. Taille M. Bande de couleur rouge.*

Ref.	Tipo Type Type	Euros
A-2002	M 8	20,00



**Guantes protección textil, 2 un. Talla grande. Banda de color azul**

Textile cut-protection gloves. Size L. Band of blue color

*Gants anti coupures textile. Taille L. Bande de couleur bleue*

Ref.	Tipo Type Type	Euros
A-2003	L 9	20,00



**Guantes protección textil, 2 un. Talla muy grande. Banda de color naranja**

Textile cut-protection gloves. Size XL. Orange band

*Gants anti coupures textile. Taille XL. Bande orange*

Ref.	Tipo Type Type	Euros
A-2004	XL 10	20,00



**Manopla silicona 300°**

Silicon oven mitts 300°

*Gant antichaleur silicone 300°*

Ref.	Euros
A-3000	39,00

**Manopla silicona 300° extra larga**

Silicon oven mitts 300°

*Gant antichaleur silicone 300° XL*

Ref.	Euros
A-3005	56,00







**Delantal malla acero CHAINEX**  
**Medidas 75 x 55**

Stainless steel mesh apron CHAINEX  
 Size 75 x 55

*Tablier maille acier inox CHAINEX*  
*Medidas 75 x 55*

Ref.	Medidas Size Dimensions	Euros
A-9-76M	75 x 55 cm	230,00



**Delantal PVC**

PVC apron

Tablier PVC

Ref.	Medidas Size Dimensions	Color Colour Couleur	Euros
A-11-120-AZ	70 x 120	●	21,00
A-11-90	70 x 90	○	18,00
A-11-90-AZ	70 x 90	●	18,00
A-11-90-N	70 x 90	●	18,00
A-11-90-R	70 x 90	●	18,00



**Delantal TPU ligero**

TPU apron LIGHT

Tablier TPU LÉGER

Ref.	Medidas Size Dimensions	Color Colour Couleur	Euros
A-11-110	87 x 115	○	46,00

**Delantal textil**

Textile apron

Tablier textile

Ref.	Medidas Size Dimensions	Euros
A-17-B	75 x 90 cm	13,50
A-17-P	75 x 90 cm	13,50
A-17-BU	75 x 90 cm	13,50
A-17-F	75 x 90 cm	13,50
A-17-N	75 x 90 cm	13,50

**Delantal textil rayado**

Textil apron striped

Tablier textile rayé

Ref.	Medidas Size Dimensions	Euros
A-17-NV	75 x 90 cm	17,50
A-17-NBU	75 x 90 cm	17,50
A-17-BR	75 x 90 cm	17,50
A-17-BAZ	75 x 90 cm	17,50
A-17-BV	75 x 90 cm	17,50



**Guantes nitrilo**  
Paquete 100 uds.

Nitrile gloves  
100 units per box

Gants nitrile  
Boîte 100 uts.

Ref.	Tipo Type Type	Euros
A-38-P	S	7,50
A-38-M	M	7,50
A-38-G	L	7,50



**Guantes plástico "un solo uso", paquete 100 und.**

Disposable plastic gloves, 100 uts box

Gants de plastique d'un seul usage, boîte 100 uts.

Ref.	Unidades Units Unités	Euros
A-12	100	0,60



**Gorro circular blanco.**  
**Paquete 100 uds**

Round cap  
100 uts box

*Bonnet circulaire*  
*Boîte 100 uts*

Ref.	Euros
A-83 polipropileno	5,30
A-83-X polietileno	3,00

**Cubremanga polietileno**  
**Paquete 100 und**

Polyethylene sleeve cover  
100 uts box

*Polyéthylène couvre manches*  
*Boîte 100 uts*

Ref.	Euros
A-86	5,00

**Bata polietileno visitante**  
**Paquete 10 und**

Polyethylene visitor's coat  
10 uts box

*Blouse polyéthylène visiteur*  
*Boîte 10 uts*

Ref.	Euros
A-87 (CONSULTAR)	---



**Bata blanca de polipropileno**  
**Paquete 10 und**

White polypropylene coat  
10 uts box

*Blouse blanche polypropylene*  
*Boîte 10 uts*

Ref.	Euros
A-82 (CONSULTAR)	---

**Cubrezapatos azul**  
**Paquete 200 und**

Shoes cover  
200 uts box

*Couvre chaussures*  
*Boîte 200 uts*

Ref.	Euros
A-84	5,00



**Mascarilla polipropileno tres capas**  
**Paquete 50 und**

Mask in polypropylene three layers  
50 uts box

*Masque en polypropylène trois couches*  
*Boîte 10 uts*

Ref.	Euros
A-89 (CONSULTAR)	---



**Delantal polietileno 69 x 122**  
**Paquete 80 und**

Polyethylene apron 69 x 122  
80 uts box

*Tablier de polyéthylène 69 x 122*  
*Boîte 80 uts*

Ref.	Euros
A-85	5,00

1

0

**Estanterias, Plataformas, Tarima antifatiga,  
Palets, Losetas, Bancos de vestuario, Taquillas.**

---

Shelves, Platforms, Anti-fatigue mat, Pallets, Tiles,  
Locker room bench, Lockers.

---

*Étagères, Plate-formes, Sol anti-fatigue, Palettes,  
Carreaux, Banc vestiare, Casiers.*

**183 - 196**

#### **HIGIÉNICAS**

- Superficie lisa y no porosa.
- Fabricadas con resina de alta calidad.
- Evitan la condensación.
- No se oxidan.
- Cantos redondeados, para evitar accidentes.
- Colores: gris y beige.

#### **RESISTENTES**

- Resistencia a la carga 400 kg/m<sup>2</sup>.
- Temperatura desde -40°C a 80°C.
- Inalterables a ácidos, aceites, grasa y humedades.
- No se manchan con el uso de detergentes.

#### **VERSÁTILES**

- Se amplian fácilmente con nuevos elementos.
- Se amoldan sin dificultad a diferentes alturas.
- Módulos especialmente diseñados para un máximo aprovechamiento de las esquinas.
- Pies regulables (opcionales), para suelos irregulares o inclinados.
- Ruedas (opcionales).

#### **HYGIÉNIQUES**

- Surface lisse et non poreuse.
- Fabriquées avec de la résine de grande qualité.
- Évitent la condensation.
- Ne se rouillent pas.
- Bords arrondis pour éviter les blessures.
- Couleurs: Gris et beige.

#### **RÉSISTANTS**

- Résistance à la charge 400 kg/m<sup>2</sup>.
- Températures de -40°C à 80°C.
- Résistantes aux acides, huiles, graisses et à l'humidité.
- Ne se tachent pas avec l'utilisation de détergents.

#### **VERSATILES**

- Peuvent être facilement étendu avec de nouveaux éléments.
- Ils s'adaptent facilement à différentes hauteurs.
- Modules spécifiquement dessinées pour une utilisation optimale des coins.
- Pieds réglables (optionnels), pour terrains irréguliers ou inclinés.
- Roues (optionnelles).

#### **MODULABLES**

- Ils s'adaptent à toute organisation de l'espace.
- Ils sont construits sur mesure.

#### **ADAPTABLES**

- Modules dessinés pour convenir à tous les besoins.
- Ils se montent très facilement, sans avoir besoin d'outils grâce.
- Elles peuvent être déplacée aisément.

#### **HYGIENIC**

- Smooth non-porous surface.
- Manufactured with premium quality resin.
- They prevent condensation.
- Non rust.
- Rounded edges, to prevent accidents.
- Colours: Grey & beige.

#### **HARDWEARING**

- Withstand load of 400 kg/m<sup>2</sup>.
- Temperatures from -40°C to 80°C.
- Unchanging to acids, oils, grease and moisture.
- Detergents doesn't stain it.

#### **VERSATILE**

- Easily extended with new elements.
- Adaptable to different heights.
- Modules specifically designed for optimal use of corners.
- Adjustable feet (optional), for uneven or sloping floor.
- Wheels (optional).

#### **MODULAR**

- They can fit at any pace allocation.
- They can be manufacture with any measure previous order.

#### **ADAPTABLE**

- Modules designed to suit any need.
- Very easy assembly without using metallic elements.
- Its lightness makes it very easy to move.

#### **MODULARES**

- Se acoplan a cualquier distribución de espacio.
- Sobre pedido se construyen en cualquier medida.

#### **ADAPTABLES**

- Módulos diseñados para adaptarse a cualquier necesidad.
- Se montan con mucha facilidad sin precisar elementos metálicos.
- Su ligereza permite desplazarlas fácilmente.



**Estanterías de plástico 4 estantes cantos rectos**

Plastic shelves 4 shelves straight edges

Étagères en plastique 4 étagères bords droits

Ref.	Medidas Size Dimensions	Color Colour Couleur	Euros
K-104	100 x 40 x 150 cm	OO●	474,00
K-105	100 x 50 x 150 cm	OO●	527,00
K-106	100 x 60 x 150 cm	OO●	585,00
K-124	120 x 40 x 150 cm	OO●	516,00
K-125	120 x 50 x 150 cm	OO●	574,00
K-126	120 x 60 x 150 cm	OO●	644,00
K-154	150 x 40 x 150 cm	OO●	641,00
K-155	150 x 50 x 150 cm	OO●	717,00
K-156	150 x 60 x 150 cm	OO●	805,00
K-204	200 x 40 x 150 cm	OO●	734,00
K-205	200 x 50 x 150 cm	OO●	828,00
K-206	200 x 60 x 150 cm	OO●	918,00

**Estantería de plástico 5 estantes cantos rectos**

Plastic shelves 5 shelves

Étagères plastique 5 étages

Ref.	Medidas Size Dimensions	Color Colour Couleur	Euros
K-104-5	100 x 40 x 175 cm	OO●	593,00
K-105-5	100 x 50 x 175 cm	OO●	658,00
K-106-5	100 x 60 x 175 cm	OO●	730,00
K-124-5	120 x 40 x 175 cm	OO●	644,00
K-125-5	120 x 50 x 175 cm	OO●	718,00
K-126-5	120 x 60 x 175 cm	OO●	805,00
K-154-5	150 x 40 x 175 cm	OO●	802,00
K-155-5	150 x 50 x 175 cm	OO●	909,00
K-156-6	150 x 60 x 175 cm	OO●	1007,00
K-204-5	200 x 40 x 150 cm	OO●	918,00
K-205-5	200 x 50 x 175 cm	OO●	1035,00
K-206-5	200 x 60 x 175 cm	OO●	1147,00



**Rueda poliamida sin stop + refuerzo**

Polyamide wheel without stop + reinforcement

Roue polyamide sans stop + reinforcement

Ref.	Euros
K-15-PS	97,00



**Rueda cincada sin stop + refuerzo**

Covered wheel without stop + reinforcement

Roue couverte sans stop + renfort

Ref.	Euros
K-15-S	73,00



**Pie regulable**

Adjustable foot

Pied réglable

Ref.	Euros
K-10	8,50



**Rueda cincada stop + refuerzo**

Covered wheel

Roue couverte

Ref.	Euros
K-15	91,00



**Rueda poliamida stop + refuerzo**

Polyamide wheel

Roue polyamide

Ref.	Euros
K-15-P	113,00



**Superficie lisa opcional polietileno 3 m/m**

Optional 3 m/m polyethylene surface  
Optionnel polyéthylène lisse 3 m/m



**Desmontadas para transporte - Fácil manejo**

Dismantled to be transported - Easy to use  
Démonté pour le transport - Fonctionnement simple

**ESTANTERÍAS RESISTENTES, HIGIÉNICAS, PLEGABLES Y VERSÁTILES**

- Resistencia a la carga 250 kg/m<sup>2</sup>.
- Temperatura desde -40°C a 80°C.
- Inalterable a la humedad, ácidos, aceites y grasas.
- No se mancha con el uso de detergentes.

**HIGIÉNICAS**

- Superficie no porosa.
- Fabricadas con resinas plásticas de alta calidad.
- Evitan la condensación.
- No se oxidan.
- Cantos romos para evitar accidentes.
- Baldas extraíbles para su lavado en lavavajillas.

**VERSÁTILES**

- Ampliables con nuevos elementos (modulares).
- Fácilmente amoldables a nuevas alturas.
- Módulos especialmente diseñados para un mejor aprovechamiento de las esquinas.
- Accesorios para diferentes utilidades.
- Plegables para el mejor aprovechamiento de espacios.
- Baldas rejadas o llenas.

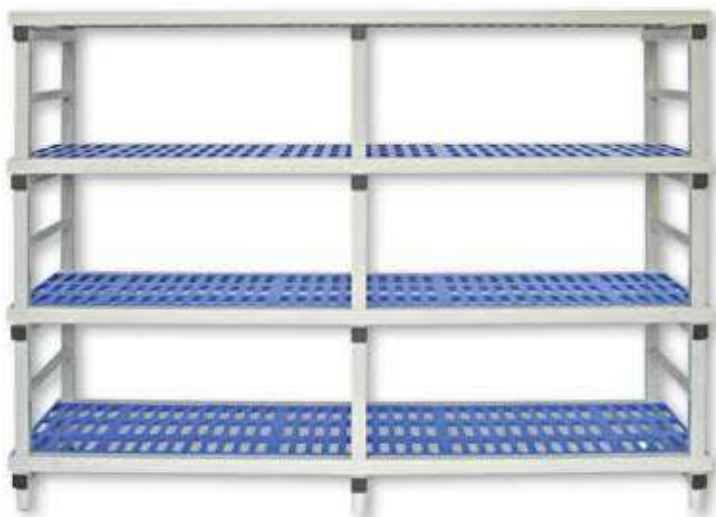

**HARDWEARING , HYGIENIC, FOLDABLE AND VERSATILE SHELVES**

- Withstand load of 250 kg/m<sup>2</sup>.
- Temperatures from -40°C a 80°C.
- Not altered by humidity, acids, oils, grease.
- Are not stained by detergents.

**HYGIENIC**

- Non-porous surface.
- Made with high quality plastic resins.
- Avoid condensation.
- Will not rust.
- Blunt edges to avoid accidents.
- Shelves removable for washing in dishwasher.

**VERSATILE**

- Expandable with new elements (modular).
- Easily adaptable to new heights.
- Modules specifically designed for optimal use of corners.
- Accessories for different utilities.
- Foldables for better use of spaces.
- Shelves grilled or plain.

**ÉTAGÈRES RÉSIDANTES, HYGIÉNIQUES, PLIANTES ET VERSATILES**

- Résistance à la charge 250 kg/m<sup>2</sup>.
- Température de -40°C a 80°C.
- Inaltérables à l'humidité, aux acides, à l'huile et aux graisses.
- Ne se tachent pas avec l'utilisation de détergents.

**HYGIÉNIQUE**

- Surface non poreuse.
- Fabriquées avec de la résine de grande qualité.
- Évitent la condensation.
- Ne se rouillent pas.
- Bords arrondis pour éviter les accidents.
- Étagères amovibles pour le lavage en lave-vaisselle.

**POLYVALENT**

- Extensibles avec de nouveaux éléments (modulaires).
- Facilement adaptables à de nouvelles hauteurs.
- Modules spécialement dessinés pour une utilisation optimale des coins.
- Accessoires pour les différentes utilisations.
- Pliantes pour une meilleure utilisation de l'espace.
- Étagères en grillé ou lisses.



Baldas en tres formatos distintos que permiten montar estanterías de distintas profundidades / Three different formats shelves that allow assembling with different depth / Étagères dans trois formats différents qui permettent le montage de différentes profondeurs

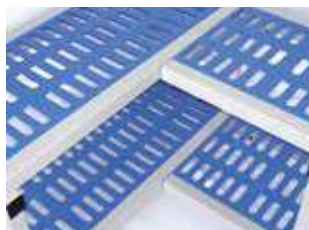

Encaje en "L" / "L" fitting / Lince "L"



Rueda / Wheel / Roues



Pata regulable / Adjustable foot / Pied réglable





Sistema de encaje /  
Fitting system /  
Système de verrouillage



KML: Estante liso / Plain shelve /  
Étagère lisse



KM: Estante rejilla



El sistema de plegado permite optimizar el volumen de empaquetado y transporte /  
Folding system makes improve packaging and transportation /  
Le système de pliage permet d'optimiser le volume des emballages et des transports

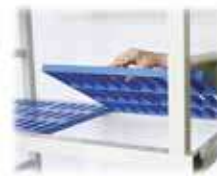

Baldas extraíbles para facilitar su lavado, pueden lavarse en el lavavajillas /  
Removable shelves to make them easy to wash, they can be cleaned in the dishwasher /  
Étagères amovibles pour faciliter le ménage, peut être lavée dans le lave-vaisselle

### Estantería de plástico plegable 5 estantes

Foldable plastic shelf 5 shelves

Étagère plastique pliante 5 étagères

Ref.	Medidas Size Dimensions	Color Colour Couleur	Euros
KM-104-5	100 x 40 x 175 cm	OO●	610,00
KM-105-5	100 x 50 x 175 cm	OO●	569,00
KM-106-5	100 x 60 x 175 cm	OO●	694,00
KM-124-S	120 x 40 x 175 cm	OO●	718,00
KM-125-5	120 x 50 x 175 cm	OO●	786,00
KM-126-5	120 x 60 x 175 cm	OO●	849,00
KM-154-5	150 x 40 x 175 cm	OO●	863,00
KM-155-5	150 x 50 x 175 cm	OO●	927,00
KM-156-5	150 x 60 x 175 cm	OO●	992,00
KM-204-5	200 x 40 x 175 cm	OO●	1016,00
KM-205-5	200 x 50 x 175 cm	OO●	1087,00
KM-206-5	200 x 60 x 175 cm	OO●	1194,00

### Estantería de plástico plegable 4 estantes

Foldable plastic shelf 4 shelves

Étagère plastique pliante 4 étagères

Ref.	Medidas Size Dimensions	Color Colour Couleur	Euros
KM-104	100 x 40 x 150 cm	OO●	487,00
KM-105	100 x 50 x 150 cm	OO●	527,00
KM-106	100 x 60 x 150 cm	OO●	556,00
KM-124	120 x 40 x 150 cm	OO●	574,00
KM-125	120 x 50 x 150 cm	OO●	630,00
KM-126	120 x 60 x 150 cm	OO●	680,00
KM-154	150 x 40 x 150 cm	OO●	690,00
KM-155	150 x 50 x 150 cm	OO●	742,00
KM-156	150 x 60 x 150 cm	OO●	794,00
KM-204	200 x 40 x 150 cm	OO●	812,00
KM-205	200 x 50 x 150 cm	OO●	870,00
KM-206	200 x 60 x 150 cm	OO●	955,00

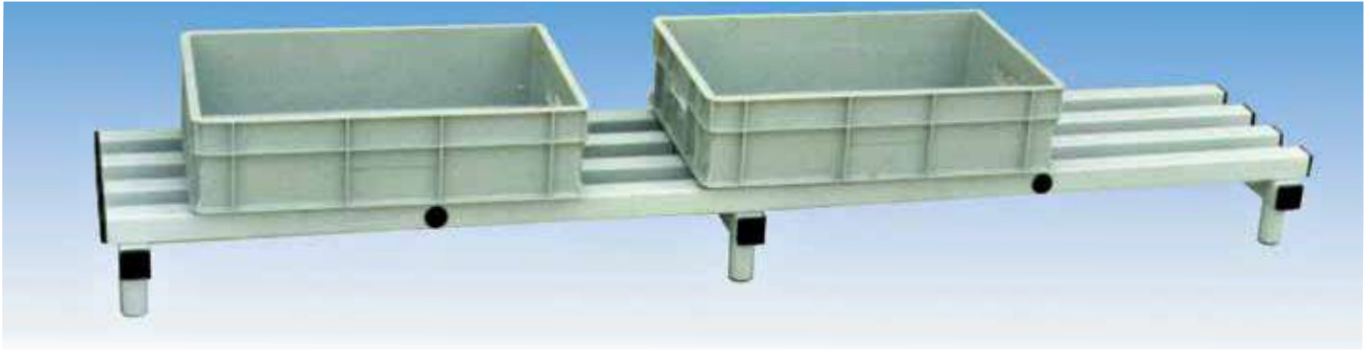

### Plataforma para suelo camara

Platform for cold storage room floor

Plate-forme pour sol chamber

Ref.	Medidas Size Dimensions	Color Colour Couleur	Euros
KP-104	100 x 40 x 16,5 cm	○○●	110,00
KP-105	100 x 50 x 16,5 cm	○○●	121,00
KP-106	100 x 60 x 16,5 cm	○○●	137,00
KP-124	120 x 40 x 16,5 cm	○○●	125,00
KP-125	120 x 50 x 16,5 cm	○○●	143,00
KP-126	120 x 60 x 16,5 cm	○○●	158,00

Ref.	Medidas Size Dimensions	Color Colour Couleur	Euros
KP-154	150 x 40 x 16,5 cm	○○●	141,00
KP-155	150 x 50 x 16,5 cm	○○●	164,00
KP-156	150 x 60 x 16,5 cm	○○●	181,00
KP-204	200 x 40 x 16,5 cm	○○●	166,00
KP-205	200 x 50 x 16,5 cm	○○●	188,00
KP-206	200 x 60 x 16,5 cm	○○●	210,00

### TARIMA ANTIFATIGA | ANTI-FATIGUE MAT | SOL ANTI-FATIGUE

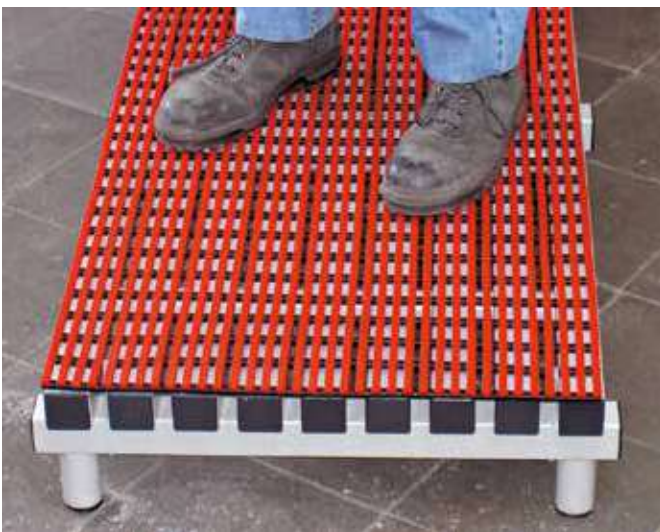

#### Tarima antifatiga

**Ergonomía:** Alfombra antifatiga, mejoran el rendimiento del trabajador, son termoaislantes, protegen contra el frío.

**Seguridad:** Evitan deslizamientos en el puesto de trabajo y posibles descargas eléctricas, calidad antideslizante de clase R10/V10.

**Medio ambiente:** Fabricadas en material reciclado.

**Color base gris, suelo azul.**

Anti-fatigue mat  
Ergonomics: Anti-fatigue carpeted mat, improve work performance, they are heat insulating, protected against the cold.

Safety: Prevent slipping over the work place and possible electric charges, class R10/V10 anti-slip quality.

Environment: Made of recycled material.

Grey base color, blue floor.

#### Sol anti-fatigue

**Ergonomie:** Tapis anti fatigue, améliore le rendement du travailleur, il est thermo isolant et protège du froid.

**Sécurité:** Il évite les glissades sur le poste de travail et d'éventuelles décharges électriques, qualité anti glissade de type R10/V10.

**Environnement:** Fait de matériaux recyclés.

Couleur de base gris, sol bleu.



Ref.	Medidas Size Dimensions	Euros
KTA-105	100 x 50 x 18 cm	443,00
KTA-106	100 x 60 x 18 cm	532,00
KTA-107	100 x 70 x 18 cm	620,00
KTA-108	100 x 80 x 18 cm	709,00



**Palet liso reciclado negro**  
Carga dinámica hasta 850 kg. Carga estática hasta 3.400 kg. Superficie apoyo 9 patas

Black smooth perforated pallet  
Dynamic load up to 850 kg. Static load up to 3.400 kg. 9-leg support surface

*Palette lisse recyclée noire*  
Charge dynamique jusqu'à 850 kg. Charge statique jusqu'à 3.400 kg. Surface soutien 9 pattes

**Palet liso alimentario blanco**  
Carga dinámica hasta 850 kg. Carga estática hasta 3.400 kg. superficie apoyo 9 patas

Smooth white food-product pallet  
Dynamic load up to 850 kg. Static load up to 3.400 kg. 9-leg support surface

*Palette unie alimentaire blanche*  
Charge dynamique jusqu'à 850 kg. Charge static jusqu'à 3.400 kg. Surface soutien 9 pattes



**Palet plástico reciclado negro**  
Carga dinámica hasta 1.000 kg. Carga estática hasta 4.000 kg

Plastic black recycled pallet  
Dynamic load up to 1.000 kg. Static load up to 4.000 kg.

*Palette plastique recyclé noire*  
Charge dynamique jusqu'à 1.000 kg. Charge statique jusqu'à 4.000 kg.

Ref.	Medidas Size Dimensions	Peso Weight Poids	Euros
KP-400	120 x 80 x 16 cm	21 kg	71,00



**Palet plástico gris alimentario**  
Carga dinámica hasta 1.000 kg. Carga estática hasta 4.000 kg.

Plastic grey pallet food  
Dynamic load up to 1.000 kg. Static load up to 4.000 kg

*Palette plastique gris nourriture*  
Charge dynamique jusqu'à 1.000 kg. Charge statique jusqu'à 4.000 kg.

Ref.	Medidas Size Dimensions	Peso Weight Poids	Euros
KP-500	120 x 80 x 16 cm	18	102,00



**Palet perforado reciclado negro**  
Carga dinámica hasta 850 kg. Carga estática hasta 3.400 kg. Superficie apoyo 9 patas

Black recycled perforated pallet  
Dynamic load up to 850 kg. Static load up to 3.400 kg. 9-leg support surface

*Palette perforée recyclée noire*  
Charge dynamique jusqu'à 850 kg. Charge statique jusqu'à 3.400 kg. Surface soutien 9 pattes

Ref.	Medidas Size Dimensions	Peso Weight Poids	Euros
KP-250	120 x 80 x 14,5 cm	6,5 kg	33,00





**Loseta suelo**

Floor tile

*Carreaux sol*

Ref.	Medidas Size Dimensions	Color Colour Couleur	Euros
KL-25	50 x 50 x 2,5 cm	● ○ ●	15,50

**Otros colores consultar.**

Consult other colors.

*Consultez d'autres couleurs.*

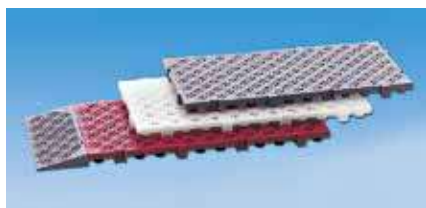

**Loseta suelo**

Floor tile

*Carreaux sol*

Ref.	Medidas Size Dimensions	Color Colour Couleur	Euros
KL-100	100 x 50 x 5 cm	● ○ ●	51,00



**Rampa para ref. KL-100 y KL-55**

Floor rampe for ref. KL-100 and KL-55

*Rampe sol for réf. KL-100 et KL-55*

Ref.	Medidas Size Dimensions	Color Colour Couleur	Euros
KL-50	50 x 20 cm	● ○ ●	23,50

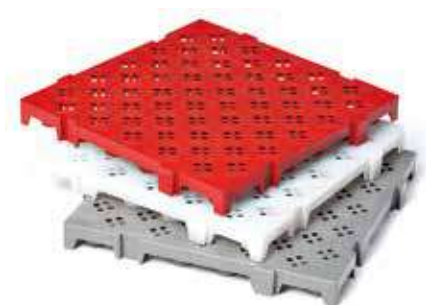

**Loseta suelo**

Floor tile

*Carreaux sol*

Ref.	Medidas Size Dimensions	Color Colour Couleur	Euros
KL-55	50 x 50 x 5 cm	● ○ ●	24,50

**BANCOS DE VESTUARIO CANTOS RECTOS | LOCKER ROOM BENCH | BANC VESTIAIRE**



**kbv - Banco vestuario**

kbv - Locker room bench

*kbv - Banc vestiaire*

Ref.	Medidas Size Dimensions	Color Colour Couleur	Euros
KBV-100	100 x 35 x 48,5 cm	○ ○ ●	268,00
KBV-150	150 x 35 x 48,5 cm	○ ○ ●	333,00
KBV-200	200 x 35 x 48,5 cm	○ ○ ●	385,00



**SON VERSÁTILES RESISTENTES  
Y MUY COMPETITIVAS /  
VERSATILES, RESISTANTS  
AND VERY COMPETITIVES /  
VERSATILES, RESISTANTS  
AND TRÈS COMPETITIVES**



**Personalización /  
Customization /  
Personnalisation**



**Patas regulables /  
Adjustable foot /  
Pied réglable**



**Cerradura de moneda /  
Coin lock /  
Pièce de verrouillage**

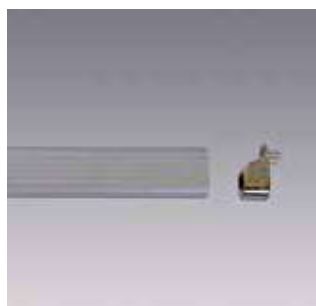

**1/2 estante y barra de colgar /  
Shelve and holding rail /  
Étagère et garde-robe**



**Cerradura estándar /  
Standard lock /  
Verrouillage standard**

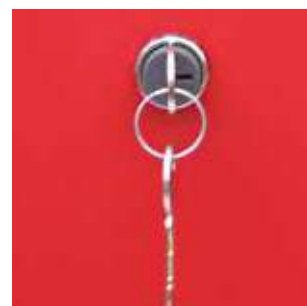

**Cerradura estándar /  
Standard lock /  
Verrouillage standard**



**Cierre por resbalón /  
Easy lock /  
Fermature par glissement**

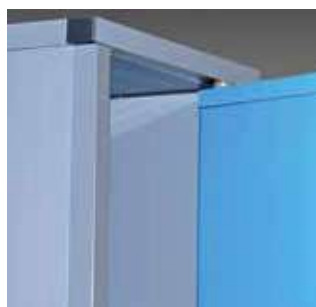

**Puerta pivotante /  
Hinging door /  
Porte pivotante**



**1/2 estante y barra de colgar /  
Shelve and holding rail /  
Étagère et garde-robe**



**Pulsera numerada /  
Numbered bracelet /  
Bracelet numéree**

**GAMA 300**

**Cerradura de tipo pitones con 3.120 nº de combinaciones.**  
**Cierre central y posibilidad de amaestramiento.**  
**Color carcás en gris.**  
**Color de la puerta en azul, rojo, beige o gris claro.**

**Material resinas de polivinilo.**  
**Patás regulables de 13 a 18 cms.**  
**Clasificación M1 según norma UNE 23727.**

**GAMA 300**

Cerradura de tipo pitones con 3.120 nº de combinaciones.  
 Cierre central y posibilidad de amaestramiento.  
 Color carcás en gris.  
 Color de la puerta en azul, rojo, beige o gris claro.

Material resinas de polivinilo.  
 Patás regulables de 13 a 18 cms.  
 Clasificación M1 según norma UNE 23727.

**GAMA 300**

Cerradura de tipo pitones con 3.120 nº de combinaciones.  
 Cierre central y posibilidad de amaestramiento.  
 Color carcás en gris.  
 Color de la puerta en azul, rojo, beige o gris claro.

Material resinas de polivinilo.  
 Patás regulables de 13 a 18 cms.  
 Clasificación M1 según norma UNE 23727.

	Módulo Module Module	Puerta Door Porte	Nº de Puertas Nº of doors Nº de portes	Medidas exterior total Total external size Dimension extérieure totale	Hueco útil por taquilla Useful space Creux utile	Ref.	Euros	Accesorios incluidos Accessories included Accessoires inclus
	M1	P1	1	29,4 x 53,7 x 191,5 cm	24,6 x 48,9 x 174 cm	K3M1P1	410,00	
	M2	P1	2	55,7 x 53,7 x 191,5 cm	24,6 x 48,9 x 174 cm	K3M2P1	739,00	
	M3	P1	3	82,2 x 53,7 x 191,5 cm	24,6 x 48,9 x 174 cm	K3M3P1	1068,00	1/2 Estante y barra Shelve and holding rail
	M4	P1	4	108,7 x 53,7 x 191,5 cm	24,6 x 48,9 x 174 cm	K3M4P1	1397,00	Étagere et garderobe
	M5	P1	5	135,2 x 53,7 x 191,5 cm	24,6 x 48,9 x 174 cm	K3M5P1	1725,00	
	M6	P1	6	161,7 x 53,7 x 191,5 cm	24,6 x 48,9 x 174 cm	K3M6P1	2054,00	
	M1	P2	2	29,4 x 53,7 x 191,5 cm	24,6 x 48,9 x 85,9 cm	K3M1P2	492,00	
	M2	P2	4	55,7 x 53,7 x 191,5 cm	24,6 x 48,9 x 85,9 cm	K3M2P2	909,00	
	M3	P2	6	82,2 x 53,7 x 191,5 cm	24,6 x 48,9 x 85,9 cm	K3M3P2	1326,00	Barra de colgar Holding rail
	M4	P2	8	108,7 x 53,7 x 191,5 cm	24,6 x 48,9 x 85,9 cm	K3M4P2	1744,00	Garde-robe barre
	M5	P2	10	135,2 x 53,7 x 191,5 cm	24,6 x 48,9 x 85,9 cm	K3M5P2	2161,00	
	M6	P2	12	161,7 x 53,7 x 191,5 cm	24,6 x 48,9 x 85,9 cm	K3M6P2	2579,00	
	M1	P3	3	29,4 x 53,7 x 191,5 cm	24,6 x 48,9 x 56,5 cm	K3M1P3	571,00	
	M2	P3	6	55,7 x 53,7 x 191,5 cm	24,6 x 48,9 x 56,5 cm	K3M2P3	1055,00	
	M3	P3	9	82,2 x 53,7 x 191,5 cm	24,6 x 48,9 x 56,5 cm	K3M3P3	1606,00	
	M4	P3	12	108,7 x 53,7 x 191,5 cm	24,6 x 48,9 x 56,5 cm	K3M4P3	2070,00	
	M5	P3	15	135,2 x 53,7 x 191,5 cm	24,6 x 48,9 x 56,5 cm	K3M5P3	2566,00	
	M6	P3	18	161,7 x 53,7 x 191,5 cm	24,6 x 48,9 x 56,5 cm	K3M6P3	3063,00	
	M1	P4	4	29,4 x 53,7 x 191,5 cm	24,6 x 48,9 x 41,8 cm	K3M1P4	659,00	
	M2	P4	8	55,7 x 53,7 x 191,5 cm	24,6 x 48,9 x 41,8 cm	K3M2P4	1224,00	
	M3	P4	12	82,2 x 53,7 x 191,5 cm	24,6 x 48,9 x 41,8 cm	K3M3P4	1870,00	
	M4	P4	16	108,7 x 53,7 x 191,5 cm	24,6 x 48,9 x 41,8 cm	K3M4P4	2448,00	
	M5	P4	20	135,2 x 53,7 x 191,5 cm	24,6 x 48,9 x 41,8 cm	K3M5P4	3036,00	
	M6	P4	24	161,7 x 53,7 x 191,5 cm	24,6 x 48,9 x 41,8 cm	K3M6P4	3624,00	
	M1	P5	5	29,4 x 53,7 x 191,5 cm	24,6 x 48,9 x 33 cm	K3M1P5	748,00	
	M2	P5	10	55,7 x 53,7 x 191,5 cm	24,6 x 48,9 x 33 cm	K3M2P5	1397,00	
	M3	P5	15	82,2 x 53,7 x 191,5 cm	24,6 x 48,9 x 33 cm	K3M3P5	2151,00	
	M4	P5	20	108,7 x 53,7 x 191,5 cm	24,6 x 48,9 x 33 cm	K3M4P5	2835,00	
	M5	P5	25	135,2 x 53,7 x 191,5 cm	24,6 x 48,9 x 33 cm	K3M5P5	3519,00	
	M6	P5	30	161,7 x 53,7 x 191,5 cm	24,6 x 48,9 x 33 cm	K3M6P5	4204,00	

**NOTA: Las taquillas se suministran desmontadas, techo, suelo, laterales y fondo. El ensamblaje se realiza, encajando los dos laterales al fondo y uniendo mediante 12 tornillos el techo, el suelo y la puerta (tiempo 5 min.).**

NOTE: All lockers are provided disassembled, roof, walls and floor. The assembling works fitting both walls to the back-side and fixing through 12 screws the roof, floor and door (5 min.).

NOTE: Toutes les casiers sont fournis sans monter, plafond, sol, fond et murs. Pour de monter, encaisser des murs au le fond et ajuster moyennant 12 visés au plafond, sol et porte (5 min.).

Accesorios / Accessories / Accessoires

Precio PVP / Retail price / Prix conseillé

1/2 Estante / 1/2 Shelve / 1/2 Étagère	26,00
1 Estante / 1 Shelve / 1 Étagère	37,00
Barra de colgar / Holding rail / Garde-robe	16,50
Patas regulables / Adjustable foot / Pied réglable	<i>incluidas / included / inclus</i>
Zócalo 1 módulo lateral / Baseboard 1 lateral module / Plinthe 1 module central	41,60
Zócalo módulo central / Baseboard central module / Plinthe module central	13,50
Muñequera llave numerada / Numbered bracelet / Braclet numérée	15,00
Numeración placa de 30 x 15 / Sheet numeration of 30 x 15 / Numération plaque 30 x 15	8,00
Techo inclinado 1 módulo laterales / Sloping roof lateral modules / Plafond incliné module lateral	86,00
Techo inclinado 1 módulo central / Sloping roof central modules / Plafond incliné module central	43,00
Cerradura de seguridad / Safe lock / Verrouillage de sécurité	<i>CONSULTAR / CONSULT / CONSULTER</i>
Cerradura de monedas / Coins lock / Verrouillage avec des pièces	37,00

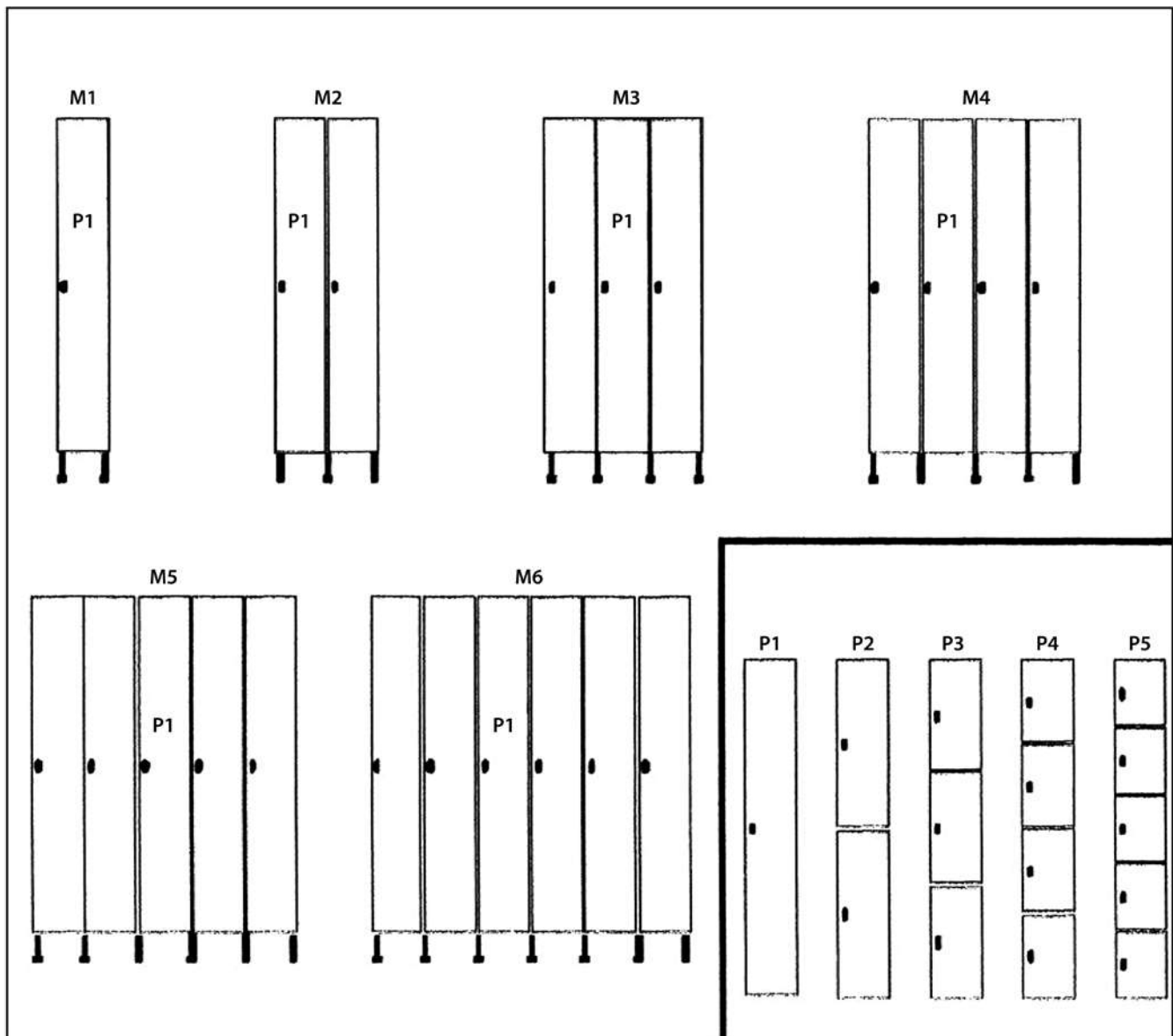



**GAMA 400**  
 Cerradura de tipo pitones con 3.120 nº de combinaciones.  
 Cierre central y posibilidad de amaestramiento.  
 Color carcás en gris.  
 Color de la puerta en azul, rojo, beige o gris claro.

Material resinas de polivinilo.  
 Patas regulables de 13 a 18 cms.  
 Clasificación M1 según norma UNE 23727.

GAMA 400  
 Cerradura de tipo pitones con 3.120 nº de combinaciones.  
 Cierre central y posibilidad de amaestramiento.  
 Color carcás en gris.  
 Color de la puerta en azul, rojo, beige o gris claro.

Material resinas de polivinilo.  
 Patas regulables de 13 a 18 cms.  
 Clasificación M1 según norma UNE 23727.

GAMA 400  
 Cerradura de tipo pitones con 3.120 nº de combinaciones.  
 Cierre central y posibilidad de amaestramiento.  
 Color carcás en gris.  
 Color de la puerta en azul, rojo, beige o gris claro.

Material resinas de polivinilo.  
 Patas regulables de 13 a 18 cms.  
 Clasificación M1 según norma UNE 23727.

	Módulo Module Module	Puerta Door Porte	Nº de Puertas Nº of doors Nº de portes	Medidas exterior total Total external size Dimension extérieure totale	Hueco útil por taquilla Useful space Creux utile	Ref.	Euros	Accesorios incluidos Accessories included Accessoires inclus
	M1	P1	1	39,5 x 53,7 x 191,5 cm	34,6 x 48,9 x 174 cm	K4M1P1	434,00	
	M2	P1	2	76,2 x 53,7 x 191,5 cm	34,6 x 48,9 x 174 cm	K4M2P1	787,00	
	M3	P1	3	112,9 x 53,7 x 191,5 cm	34,6 x 48,9 x 174 cm	K4M3P1	1139,00	1/2 Estante y barra
	M4	P1	4	149,6 x 53,7 x 191,5 cm	34,6 x 48,9 x 174 cm	K4M4P1	1492,00	Shelve and holding rail
	M5	P1	5	186,3 x 53,7 x 191,5 cm	34,6 x 48,9 x 174 cm	K4M5P1	1845,00	Étagere et garde-robe
	M6	P1	6	223 x 53,7 x 191,5 cm	34,6 x 48,9 x 174 cm	K4M6P1	2199,00	
	M1	P2	2	39,5 x 53,7 x 191,5 cm	34,6 x 48,9 x 85,9 cm	K4M1P2	517,00	
	M2	P2	4	76,2 x 53,7 x 191,5 cm	34,6 x 48,9 x 85,9 cm	K4M2P2	958,00	
	M3	P2	6	112,9 x 53,7 x 191,5 cm	34,6 x 48,9 x 85,9 cm	K4M3P2	1401,00	Barra de colgar
	M4	P2	8	149,6 x 53,7 x 191,5 cm	34,6 x 48,9 x 85,9 cm	K4M4P2	1844,00	Holding rail
	M5	P2	10	186,3 x 53,7 x 191,5 cm	34,6 x 48,9 x 85,9 cm	K4M5P2	2287,00	Garde-robe barre
	M6	P2	12	223 x 53,7 x 191,5 cm	34,6 x 48,9 x 85,9 cm	K4M6P2	2728,00	
	M1	P3	3	39,5 x 53,7 x 191,5 cm	34,6 x 48,9 x 56,5 cm	K4M1P3	598,00	
	M2	P3	6	76,2 x 53,7 x 191,5 cm	34,6 x 48,9 x 56,5 cm	K4M2P3	1109,00	
	M3	P3	9	112,9 x 53,7 x 191,5 cm	34,6 x 48,9 x 56,5 cm	K4M3P3	1666,00	
	M4	P3	12	149,6 x 53,7 x 191,5 cm	34,6 x 48,9 x 56,5 cm	K4M4P3	2194,00	
	M5	P3	15	186,3 x 53,7 x 191,5 cm	34,6 x 48,9 x 56,5 cm	K4M5P3	2720,00	
	M6	P3	18	223 x 53,7 x 191,5 cm	34,6 x 48,9 x 56,5 cm	K4M6P3	3273,00	
	M1	P4	4	39,5 x 53,7 x 191,5 cm	34,6 x 48,9 x 41,8 cm	K4M1P4	688,00	
	M2	P4	8	76,2 x 53,7 x 191,5 cm	34,6 x 48,9 x 41,8 cm	K4M2P4	1283,00	
	M3	P4	12	112,9 x 53,7 x 191,5 cm	34,6 x 48,9 x 41,8 cm	K4M3P4	1968,00	
	M4	P4	16	149,6 x 53,7 x 191,5 cm	34,6 x 48,9 x 41,8 cm	K4M4P4	2594,00	
	M5	P4	20	186,3 x 53,7 x 191,5 cm	34,6 x 48,9 x 41,8 cm	K4M5P4	3218,00	
	M6	P4	24	223 x 53,7 x 191,5 cm	34,6 x 48,9 x 41,8 cm	K4M6P4	3870,00	
	M1	P5	5	39,5 x 53,7 x 191,5 cm	34,6 x 48,9 x 33 cm	K4M1P5	779,00	
	M2	P5	10	76,2 x 53,7 x 191,5 cm	34,6 x 48,9 x 33 cm	K4M2P5	1460,00	
	M3	P5	15	112,9 x 53,7 x 191,5 cm	34,6 x 48,9 x 33 cm	K4M3P5	2277,00	
	M4	P5	20	149,6 x 53,7 x 191,5 cm	34,6 x 48,9 x 33 cm	K4M4P5	3004,00	
	M5	P5	25	186,3 x 53,7 x 191,5 cm	34,6 x 48,9 x 33 cm	K4M5P5	3731,00	
	M6	P5	30	223 x 53,7 x 191,5 cm	34,6 x 48,9 x 33 cm	K4M6P5	4484,00	

**NOTA:** Las taquillas se suministran desmontadas, techo, suelo, laterales y fondo. El ensamblaje se realiza, encajando los dos laterales al fondo y uniendo mediante 12 tornillos el techo, el suelo y la puerta (tiempo 5 min.).

NOTE: All lockers are provided disassembled, roof, walls and floor. The assembling works fitting both walls to the back-side and fixing through 12 screws the roof, floor and door (5 min.).

NOTE: Toutes les casiers sont fournis sans monter, plafond, sol, fond et murs. Pour de monter, encaisser des murs au le fond et ajuster moyennant 12 vises au plafond, sol et porte (5 min.).

**GAMA 400 D Vertical**  
**Cerradura de tipo pitones con 3.120 n° de combinaciones.**  
**Cierre central y posibilidad de amaestramiento.**  
**Color carcás en gris.**  
**Color de la puerta en azul, rojo, beige o gris claro.**

GAMA 400 D Vertical  
 Cerradura de tipo pitones con 3.120 n° de combinaciones.  
 Cierre central y posibilidad de amaestramiento.  
 Color carcás en gris.  
 Color de la puerta en azul, rojo, beige o gris claro.

GAMA 400 D Vertical  
 Cerradura de tipo pitones con 3.120 n° de combinaciones.  
 Cierre central y posibilidad de amaestramiento.  
 Color carcás en gris.  
 Color de la puerta en azul, rojo, beige o gris claro.

**Material resinas de polivinilo.**  
**Patás regulables de 13 a 18 cms.**  
**Clasificación M1 según norma UNE 23727.**

Material resinas de polivinilo.  
 Patás regulables de 13 a 18 cms.  
 Clasificación M1 según norma UNE 23727.

Material resinas de polivinilo.  
 Patás regulables de 13 a 18 cms.  
 Clasificación M1 según norma UNE 23727.

	Módulo Module Module	Puerta Door Porte	N° de Puertas N° of doors N° de portes	Medidas exterior total Total external size Dimension extérieure totale	Hueco útil por taquilla Useful space Creux utile	Ref.	Euros	Accesorios incluidos Accessories included Accessoires inclus
	M1	P1	1	39,5 x 53,7 x 191,5 cm	16,2 x 48,9 x 174 cm	KD4M1P1	542,00	
	M2	P1	2	76,2 x 53,7 x 191,5 cm	16,2 x 48,9 x 174 cm	KD4M2P1	1003,00	Estante, barra y división vertical Shelve, rail and vertical wall Étagèr, barre et séparateur
	M3	P1	3	112,9 x 53,7 x 191,5 cm	16,2 x 48,9 x 174 cm	KD4M3P1	1463,00	
	M4	P1	4	148,7 x 53,7 x 191,5 cm	16,2 x 48,9 x 174 cm	KD4M4P1	1924,00	
	M5	P1	5	186,3 x 53,7 x 191,5 cm	16,2 x 48,9 x 174 cm	KD4M5P1	2385,00	
	M6	P1	6	223 x 53,7 x 191,5 cm	16,2 x 48,9 x 174 cm	KD4M6P1	2848,00	
	M1	P2	2	39,5 x 53,7 x 191,5 cm	16,2 x 48,9 x 85,9 cm	KD4M1P2	631,00	
	M2	P2	4	75,7 x 53,7 x 191,5 cm	16,2 x 48,9 x 85,9 cm	KD4M2P2	1187,00	
	M3	P2	6	112,2 x 53,7 x 191,5 cm	16,2 x 48,9 x 85,9 cm	KD4M3P2	1743,00	
	M4	P2	8	148,7 x 53,7 x 191,5 cm	16,2 x 48,9 x 85,9 cm	KD4M4P2	2299,00	
	M5	P2	10	155,2 x 53,7 x 191,5 cm	16,2 x 48,9 x 85,9 cm	KD4M5P2	2856,00	
	M6	P2	12	221,7 x 53,7 x 191,5 cm	16,2 x 48,9 x 85,9 cm	KD4M6P2	3412,00	

**NOTA: Las taquillas se suministran desmontadas, techo, suelo, laterales y fondo. El ensamblaje se realiza, encajando los dos laterales al fondo y uniendo mediante 12 tornillos el techo, el suelo y la puerta (tiempo 5 min.).**

NOTE: All lockers are provided disassembled, roof, walls and floor. The assembling works fitting both walls to the back-side and fixing through 12 screws the roof, floor and door (5 min.).

NOTE: Toutes les casiers sont fournis sans monter, plafond, sol, fond et murs. Pour de monter, encaisser des murs au le fond et ajuster moyennant 12 visés au plafond, sol et porte (5 min.).

Accesorios / Accessories / Accessoires	Precio PVP / Retail price / Prix conseillé
1/2 Estante / 1/2 Shelve / 1/2 Étagère	27,00
1 Estante / 1 Shelve / 1 Étagère	38,00
Barra de colgar / Holding rail / Garde-robe	17,50
Patás regulables / Adjustable foot / Pied réglable	<b>incluidas / included / inclus</b>
Zócalo 1 módulo lateral / Baseboard 1 lateral module / Plinthe 1 module central	42,00
Zócalo módulo central / Baseboard central module / Plinthe module central	14,50
Muñequera llave numerada / Numbered bracelet / Braçlet numéree	15,00
Numeración placa de 30 x 15 / Sheet numeration of 30 x 15 / Numération plaque 30 x 15	8,00
Techo inclinado 1 módulo laterales / Sloping roof lateral modules / Plafond incliné module lateral	86,00
Techo inclinado 1 módulo central / Sloping roof central modules / Plafond incliné module central	43,00
Cerradura de seguridad / Safe lock / Verrouillage de sécurité	<b>CONSULTAR / CONSULT / CONSULTER</b>
Cerradura de monedas / Coins lock / Verrouillage avec des pièces	37,00

**NOTA: Las taquillas se suministran desmontadas, techo, suelo, laterales y fondo. El ensamblaje se realiza, encajando los dos laterales al fondo y uniendo mediante 12 tornillos el techo, el suelo y la puerta (tiempo 5 min.).**

NOTE: All lockers are provided disassembled, roof, walls and floor. The assembling works fitting both walls to the back-side and fixing through 12 screws the roof, floor and door (5 min.).

NOTE: Toutes les casiers sont fournis sans monter, plafond, sol, fond et murs. Pour le monter, encaisser des murs au le fond et ajuster moyennant 12 visés au plafond, sol et porte (5 min.).

## Recambios

**Carteles portaprecios, Guantes acero-inox, Indicadores de turno, Grifos ducha, Soldadores de bolsa, Esterilizadores, Máquinas retractilar, Máquinas cierra bolsas, Hamburgueseras, Máquinas cierra bolsas, Etiquetadoras, Abrelatas, Exterminadores-tubos.**

---

## Spare Parts

Tag holders, Stainless steel gloves, Queue indicators, Shower taps, Bag sealers, Sterilisers, Wrapping machines, Burguer presses, Labellers, Can opener, Insect exterminators-tubes.

---

## *Pieces de Rechange*

*Affiches porte-prix, Gants d'inox, Indicateurs de tour, Robinets douche, Scelleuse de sacs, Stérilisateurs, Machines à retractiler, Machine ferme sacs, Hachoirs, Étiqueteusses, Ouvre-boîtes, Exterminateurs d'insectes-tubes.*

**Números**

Numbers

*Numerós*

Ref.	Para For Pour	Euros
C-103	C-26	1,05
C-104	C-27, C-28, C-50	1,05
C-108	C-19, C-20, C-21, C-25, C-35, C-40, C-41, C-52	1,20
C-110	C-31, C-32, C-33	2,10
C-115	C-30, C-34	3,70

**Números (Caja 24 juegos números / Ref. C-121 números dobles)**

Numbers (Box with 24 sets of numbers / Ref. C-121 double numbers)

*Numerós (Boîte avec 24 jeux de numéros / Ref. C-121 numéros doubles)*

Ref.	Para For Pour	Euros
C-121	C-44	31,50
C-122	C-42	24,50

**GUANTES ACERO INOXIDABLE** | STAINLESS STEEL GLOVES | *GANTS D'ACIER INOX*

**Banda plástico**

Plastic band

*Bande plastique*

Ref.	Color Colour Couleur	Euros
A-1050-B	●	8,00
A-1051-B	●	8,00
A-1052-B	○	8,00

Ref.	Color Colour Couleur	Euros
A-1053-B	●	8,00
A-1054-B	●	8,00
A-1055-B	●	8,00

**INDICADORES DE TURNO** | QUEUE INDICATORS | *INDICATEURS DE TOUR*

**SopORTE pared**

Wall holder

*Support par mur*

Ref.	Para For Pour	Euros
ET-108	ET-1	4,50

**Caja control**

Control pad with cable

*Télécommande avec fil pour*

Ref.	Para For Pour	Euros
IT-103	IT-4, IT-6	65,00

**Caja control**

Control pad with cable

*Commande avec fil pour*

Ref.	Para For Pour	Euros
IT-110	IT-8	58,00

**Mando a distancia**

Remote control

*Télécommande*

Ref.	Para For Pour	Euros
IT-105	IT-5-MD	52,00

**Mando a distancia**

Remote control

*Télécommande*

Ref.	Para For Pour	Euros
IT-105-	IT-7-MD	52,00

**Mando a distancia con visor**

Remote control

*Télécommande*

Ref.	Para For Pour	Euros
IT-105-V	IT-5-MDV	77,00

**Mando a distancia (1 función)**

Remote control (1 function)

*Télécommande (1 fonction)*

Ref.	Para For Pour	Euros
IT-107	IT-4-MD, IT-6-MD, IT-5-MD	51,00

**Mando a distancia (2 funciones)**

Remote control (2 functions)

*Télécommande (2 fonctions)*

Ref.	Para For Pour	Euros
IT-106	IT-6-MD, IT-8-MD	66,00

**Mando a distancia (3 funciones)**

Remote control (3 functions)

*Télécommande (3 fonctions)*

Ref.	Para For Pour	Euros
IT-109	IT-4-MD	71,00



### Resistencia y teflón

Heating element and teflon cloth

Élément coupant et téflon

Ref.	Para For Pour	Euros
SB-201	SB-200	13,00
SB-301	SB-300	13,00
SB-401	SB-400	13,00
SB-501	SB-500	15,00

### Resistencia

Resistance

Résistance

Ref.	Para For Pour	Euros
SBPA-451	SBPA-450	26,50
SBPA-601	SBPA-600	30,00

### Termóstato

Thermostat

Thermostat

Ref.	Para For Pour	Euros
SB-202	SB-200	57,50
SB-302	SB-300	57,50
SB-402	SB-400	57,50
SB-502	SB-500	60,00

### Rollo teflón

Teflon cloth roll

Rouleau de téflon

Ref.	Para For Pour	Euros
SB-602	SBP-450/600, SBM-600	53,00

### Resistencia

Heating element

Élément coupant

Ref.	Para For Pour	Euros
SB-451	SBP-450	17,50
SB-601	SBP-600, SBM-600, SB-600	19,00
SB-1001	SB-1000	25,50

## ESTERILIZADORES | STERILISERS | STÉRILISATEURS

### Circuito eléctrico completo temporizado

Complete electric circuit

Circuit électrique complet

Ref.	Para For Pour	Euros
EC-710	EC-1, EC-55, EC-105	218,00

### Base conexión macho con toma red + portafusible

Plug connection with power point + fuse carrier

Base connection prise + portafusible

Ref.	Para For Pour	Euros
EC-711	EC-1, EC-55, EC-105	33,50

### Pulsador redondo para encendido

On button

Bouton de branchement

Ref.	Para For Pour	Euros
EC-712	EC-1, EC-55, EC-105	7,00

## ESTERILIZADORES | STERILISERS | STÉRILISATEURS

### Cable de corriente

Power cable

Cable courant électrique

Ref.	Para For Pour	Euros
EC-713	EC-1, EC-55, EC-105	7,50

### Fusible

Fuse

Fusible

Ref.	Para For Pour	Euros
EC-714	EC-1, EC-55, EC-105	2,00

### Lámpara ozono con soporte

Ozone lamp with stand

Lampe d'ozone avec support

Ref.	Para For Pour	Euros
EC-715	EC-1, EC-55, EC-105	38,00

### Lámpara UV germicida 15 W

UV germicide lamp 15 W

Lampe UV germicide 15 W

Ref.	Para For Pour	Euros
ECU-15	ECU-25, ECU-50, ECU-100	47,50

### Resistencia de corte

Heating element

Élément coupant

Ref.	Para For Pour	Euros
MR-201	MR-2, MR-4	47,50
MR-201-ECO	MR-4-ECO	41,50
MR-206	MR-4-500	45,50
MR-206-ECO	MR-4-500-ECO	41,00

### Termostato

Thermostat

Thermostat

Ref.	Para For Pour	Euros
MR-203	MR-4, MR-4-500	24,50

### Interruptor general

General switch

Interrupteur général

Ref.	Para For Pour	Euros
MR-207	MR-4, MR-4-500	19,00

### Resistencia de corte

Heating element

Élément coupant

Ref.	Para For Pour	Euros
MR-210	MR-4-600	49,00
MR-215	MR-3	35,00

### Rueda termostato

Thermostat wheel

Roulette de thermostat

Ref.	Para For Pour	Euros
MR-204	MR-4, MR-4-500	8,00

### Interruptor placa de calor o resistencia

Heat plate and heating element on/off switch

Interrupteur pour element coupant et plaque de chauffage

Ref.	Para For Pour	Euros
MR-208	MR-4, MR-4-500	8,00

### Placa de calor

Heat plate

Plaque de chauffage

Ref.	Para For Pour	Euros
MR-202	MR-4, MR-4-500	81,00
MR-202-ECO	MR-4-ECO	60,00

### Portafusible con fusible

Fuse carrier with fuse

Portafusible avec fusible

Ref.	Para For Pour	Euros
MR-205	MR-4, MR-4-500	5,50

### Piloto señalización

Sign light

Lumineux

Ref.	Para For Pour	Euros
MR-209	MR-4, MR-4-500	8,50

## MÁQUINAS CIERRA BOLSAS | BAG SEALERS | MACHINE FERME SACS

### Rueda rollo

Roll wheel

Roulette rouleau

Ref.	Para For Pour	Euros
CB-10	CB-101	3,50

### Rueda rollo

Roll wheel

Roulette rouleau

Ref.	Para For Pour	Euros
CB-11	CB-606	3,50

## HAMBURGUESERAS | BURGUER PRESSES | HACHOIRS

### Palanca prensa

Press lever

Levier presse

Ref.	Para For Pour	Euros
MH-101	MH-2	82,50

### Pala doble

Double slice

Pelle double

Ref.	Para For Pour	Euros
MH-102	MH-2	82,50
MH-105	MH-3, MH-4	60,50

### Pala doble redonda

Round double slice

Pelle double ronde

Ref.	Para For Pour	Euros
MH-107	MH-5	60,50
MH-6-1	MH-6	61,00
MH-7-1	MH-7	66,00
MH-8-1	MH-8	83,00
MH-9-1	MH-9	83,00

**Pala ovalada**

Oval shovel

*Pelle oval*

Ref.	Para For Pour	Euros
MH-111	MH-1	15,00

**Pala redonda**

Round shovel

*Pelle ronde*

Ref.	Para For Pour	Euros
MH-112	MH-1-R	16,00

**Muelle elevación placa**

Elevator sheet spring

*Ressort elevateur plaque*

Ref.	Para For Pour	Euros
MH-104	MH-2	5,50
MH-110	MH-3, MH-4	5,50

**Muelle elevación brazo**

Elevator arm spring

*Ressort elevateur bras*

Ref.	Para For Pour	Euros
MH-103	MH-2	5,50

**Muelle elevación brazo izquierdo**

Elevator left arm spring

*Ressort elevateur bras gauche*

Ref.	Para For Pour	Euros
MH-108	MH-3, MH-4	5,50

**Muelle elevación brazo derecho**

Elevator right arm spring

*Ressort elevateur bras droite*

Ref.	Para For Pour	Euros
MH-109	MH-3, MH-4	5,50

**ETIQUETADORAS | LABELLERS | ÉTIQUETEUSES**

**Rodillo tinta**

Ink roller

*Rouleau encre*

Ref.	Para For Pour	Euros
E-110	E-5, E-6	5,00

**Rodillo tinta**

Ink roller

*Rouleau encre*

Ref.	Para For Pour	Euros
E-110-ECO	E-5-ECO, E-6-ECO	5,00

**ABRELATAS | CAN OPENER | OUVRE-BOÎTES**

**Cuchilla**

Blade

*Lame*

Ref.	Para For Pour	Euros
A-70-1	A-70	7,50

**Roldana o rueda de arrastre**

Wheel for drag

*Roulette pour traîner*

Ref.	Para For Pour	Euros
A-70-2	A-70	12,50

**Muelle de roldana**

Spring of A-70-2 for ref. A-70

*Ressort de A-70-2 pour réf. A-70*

Ref.	Para For Pour	Euros
A-70-3	A-70	5,50

**Tubo**

Tube

*Tube*

Ref.	Tipo Type	Para For Pour	Euros
<b>Z-10</b>	10 W	Z-420-MD	<b>12,00</b>
<b>Z-11</b>	11 W	Z-600	<b>12,50</b>
<b>Z-15</b>	15 W	Z-700, Z-930, Z-950, Z-430-MD	<b>14,00</b>
<b>Z-20</b>	20 W	Z-740, Z-840, Z-960	<b>15,00</b>
<b>Z-20-F</b>	18 W	Z-440-MD	<b>19,00</b>
<b>Z-40</b>	40 W	Z-780, Z-880	<b>18,00</b>

**Tubo, forma U**

Tube, U form

*Tube, forme d'U*

Ref.	Tipo Type	Para For Pour	Euros
<b>Z-11-U</b>	11 W	Z-151	<b>10,50</b>

**Lámpara bajo consumo**

Low energy lamp

*Lampe de basse consommation*

Ref.	Tipo Type	Para For Pour	Euros
<b>Z-21</b>	20 W	Z-911, Z-918	<b>17,00</b>



**0-9**

0,3 CM2	9
0010.100	168
0015.065	168
0151.310	162
0151.355	162
0151.395	162
0170.155	162
0170.185	162
0170.210	162
0170.260	162
0170.310	162
0170.355	162
0170.395	162
0370.165	162
0370.195	162
0370.225	162
0425.130	162
0425.150	162
0430.150	163
0500.305	163
0521.250	164
0521.300	164
0526.250	163
0526.300	163
0540.250	163
0540.305	163
0560.250	168
0560.310	168
0575.250	168
0575.300	168
0575.360	168
0600.300	165
0600.350	165
0701.320	163
0701.350	163
0701.370	163
0720.350	163
0720.380	163
0775.190	163
0801.230	166
0801.250	166
0801.290	166
0820.240	166
0820.260	166
0840.320	166
0850.220	166
0850.250	166
0901.290	167
0901.310	167
0905.290	167
0905.310	167
1,5 CM2	9
1000.305	167
1000.450	167
1001.260	167
1001.290	167
1001.320	167
14 CM2	9
1701.135	168
1705.150	168
1CM2	9
2 CM2	9
2002.250	167
2002.310	167
2401.230	168
2401.260	168
2460.400	174
2460.450	174
2460.500	174
2476.420	174
2476.450	174
2476.500	174
2500.330	174
2500.450	174
2500.600	174
2526.000	168
3 CM2	9
3000.200	169
3000.250	169
3000.300	169
3050.300	169
3100.300	169
3150.300	169
3200.300-A	170
3200.300-AZ	170
3200.300-N	170

3200.300-R	170
3200.300-V	170
3250.300-A	170
3250.300-AZ	170
3250.300-N	170
3250.300-R	170
3250.300-V	170
3400.300	170
3500.300	170
3900.700	171
3900.750	171
3900.995	171
4 CM2	9
4000.100	164
4000.150	164
4000.200	164
4000.250	164
4000.300	164
4010.150	164
4020.300	164
4050.180	164
4100.150	165
4100.200	164
4100.250	164
4101.250	165
4102.230	165
4105.180	165
4120.250	164
4120.300	164
4200.150	165
4200.200	165
4200.250	165
4200.280	165
4300.270	165
5 CM2	9
9 CM2	9
<b>A</b>	
A-1	41
A-1000	176
A-1001	176
A-1020	176
A-1021	176
A-1022	176
A-1023	176
A-1024	176
A-1050	176
A-1050-B	198
A-1050-X	176
A-1051	176
A-1051-B	198
A-1051-X	176
A-1052	176
A-1052-B	198
A-1052-X	176
A-1053	176
A-1053-B	198
A-1053-X	176
A-1054	176
A-1054-B	198
A-1054-X	176
A-1055	176
A-1055-B	198
A-1055-X	176
A-1110	176
A-1111	176
A-11-110	180
A-1112	176
A-11-120-AZ	180
A-1113	176
A-1114	176
A-1115	176
A-11-90	180
A-11-90-AZ	180
A-11-90-N	180
A-11-90-R	180
A-12	181
A-14	173
A-15	146
A-16	172
A-17-B	180
A-17-BAZ	180
A-17-BR	180
A-17-BU	180
A-17-BV	180
A-17-F	180
A-17-N	180
A-17-NBU	180

A-17-NV	180
A-17-P	180
A-18	174
A-198	85
A-198-1	85
A-2	174
A-20	144
A-200	86
A-2001	177
A-200-13	86
A-200-13X Circonio	86
A-2002	177
A-2003	177
A-200-33	86
A-2004	177
A-21	173
A-22	173
A-23	144
A-24	144
A-25	173
A-26	144
A-27	142
A-28	142
A-29	142
A-3	142
A-3000	178
A-3005	178
A-30-100	18
A-30-100-I	18
A-30-50	18
A-30-50-I	18
A-30-70	18
A-30-70-I	18
A-35-11	72
A-35-13	72
A-35-15	72
A-35-26	72
A-36-11	72
A-36-13	72
A-36-15	72
A-37	139
A-38-G	181
A-38-M	181
A-38-P	181
A-41	17
A-4-11	144
A-4-14	144
A-4-16	144
A-42	17
A-4-20	144
A-4-24	144
A-43	17
A-43-P	17
A-44	17
A-44-P	17
A-46	17
A-47	17
A-48-18	16
A-48-22	16
A-48-26	16
A-49	145
A-50	145
A-50-15	145
A-50-25	145
A-50-30	145
A-51	173
A-5-12	144
A-5-16	144
A-52	173
A-5-20	144
A-5-24	144
A-53	173
A-530	132
A-531	132
A-54	173
A-540	133
A-550	133
A-555	133
A-56	174
A-57	18
A-6	172
A-65	175
A-70	175
A-70-1	201
A-70-2	201
A-70-3	201
A-75	94

A-76	95
A-77	95
A-8	144
A-80	2
A-81	2
A-81-1	2
A-82 (CONSULTAR)	182
A-83 polipropileno	182
A-83-X polietileno	182
A-84	182
A-85	182
A-86	182
A-87 (CONSULTAR)	182
A-89 CONSULTAR)	182
A-90	113
A-95	113
A-9-76M	179

**B**

BA-3	48
BA-5	48
BAC-1	155
BAC-1	48
BAL-1	48
BAL-1	155
BB-1	47
BB-10	47
BB-2	47
BB-3	47
BB-4	47
BB-5	47
BB-6	47
BB-7	47
BB-8	47
BB-9	47
BBP-1	47
BBP-2	47
BBP-3	47
BBP-4	47
BBP-5	47
BC-0	49
BC-0-N	49
BC-1	49
BC-1-N	49
BC-2	49
BC-2-N	49
BC-3	49
BC-3-N	49
BC-4	49
BC-4-N	49
BC-5	49
BCR-0	49
BCR-1	49
BCR-2	49
BCR-3	49
BCR-4	49
BCR-5	49
BCR-5-N	49
BCT-0	49
BCT-1	49
BCT-2	49
BCT-3	49
BI-11	50
BI-12	50
BI-13	50
BI-14	50
BI-15-B	155
BI-15-B	50
BI-15-N	50
BI-15-N	155
BI-15-R	50
BI-15-R	155
BI-21	50
BI-21-N	50
BI-22	50
BI-22-N	50
BI-23	50
BI-23-N	50
BP-10063-N	58
BP-14330-N	60
BP-1946-N	60
BP-4013-N	58
BP-5355-N	58
BP-5356-N	59
BP-5869-N	59
BP-5921-N	59
BP-6661-N	58
BP-6665-N	58

## B-D

BP-6670-N	58	BVC-350500	97	C-30	38	C-7-B	28
BP-6675-N	58	BVE-200300	96	C-300	22	C-81	28
BP-6901-N	60	BVE-250350	96	C-301	22	C-82	28
BP-6960-N	58	BVE-300400	96	C-302	22	C-87	34
BP-9327-N	60	BVE-350450	96	C-303	22	C-87-A	34
BPA-15-50-N	57	BVE-350600	96	C-304	22	C-88	34
BPA-22G-50-N	56	BVP-175250	96	C-305	22	C-89	34
BPA-22P-50-N	57	BVP-175300	96	C-306	22	C-9	35
BPA-45-50-N	56	BVP-200250	96	C-307	22	C-90-AZ	26
BPA-90-50-N	57	BVP-200300	96	C-30-P	38	C-90-B	26
BPA-90-50-N	56	BVPO-200300	96	C-31	38	C-90-R	26
BPA-ANFI	57	BVPP-200300	96	C-310	22	C-91	28
BPA-ANFI	56	BVX-1525	95	C-311	23	C-92	28
BPA-TD-50-N	56	BVX-1535	95	C-312	23	C-93	34
BPA-TD-50-N	57	BVX-1545	95	C-313	23	C-94	34
BPA-TI-50-N	57	BVX-2020	95	C-314	23	C-95	34
BPA-TI-50-N	56	BVX-2030	95	C-315	23	C-96	34
BPB-10569-N	59	BVX-2040	95	C-317	23	C-97	28
BPB-17068-N	59	BVX-2535	95	C-32	38	C-97-N	28
BPB-17069-N	60	BVX-3040	95	C-320	32	C-98	28
BPB-17070-N	60	BVX-3050	95	C-320	23	C-98-N	28
BPB-17071-N	60	BVXC-200300	95	C-321	25	C-99	29
BPB-25140	59	BVX-R20	95	C-33	38	CB-10	200
BPB-9232-N	59	BX-4	46	C-34	32	CB-101	150
BPC-22860-N	61	BX-5	46	C-35	32	CB-11	200
BPC-22861-N	61	BX-6	46	C-35-K	32	CB-606	150
BPC-22866-N	61	BX-9	46	C-38	25	CB-800	150
BPC-24544-N	61	BXP-2	46	C-38-B	27	CC-10	45
BP-GN 1/1-50-N	54	BXP-3	46	C-39	29	CC-100	45
BP-GN 1/2-50-N	54	BXP-4	46	C-40	32	CC-12	45
BP-GN 1/3-17-N	54	BXP-5	46	C-41	32	CC-14	44
BP-GN 1/3-50-N	54	BZ-1	46	C-42-AZ	30	CC-15	45
BP-GN 1/4-17-N	54	BZ-10	46	C-42-B	31	CC-16	45
BP-GN 1/4-50-N	54	BZ-2	46	C-42-C	31	CC-19	45
BP-GN 1/5-17-N	54	BZ-3	46	C-42-G	29	CC-20	45
BP-GN 1/5-50-N	54	BZ-4	46	C-42-GAZ	29	CC-21	45
BP-GN 1/6-50-N	54	BZ-5	46	C-42-GM	29	CC-32	44
BP-GN 1/9-50-N	54	BZ-6	46	C-42-GR	29	CC-33	45
BP-GN 2/4-17-N	54	BZP-1	46	C-42-R	31	CC-40	45
BP-GN 2/5-17-N	54	BZP-2	46	C-42-V	31	CC-60	45
BP-GN 3/4-17-N	54	BZP-3	46	C-43	31	CC-9	45
BP-GN 3/4-50-N	54	BZP-4	46	C-43-A	31	CCT-39	45
BP-GN 5/4-40-N	54	<b>C</b>		C-44-AZ	30	CCT-40	45
BP-GN 1/1-17-N	54	C-1	35	C-44-B	30	CCT-60	45
BP-GN 1/2-17-N	54	C-10	24	C-44-BAZ	30	CH-1	45
BPR-1/1-N	55	C-100	29	C-44-BR	30	CH-10	44
BPR-1/2-N	55	C-103	198	C-44-BV	30	CH-100	44
BPR-1/3-N	55	C-104	198	C-44-C	30	CH-12	44
BPR-1/4-N	55	C-108	198	C-44-M	30	CH-18	44
BPR-1/5-N	55	C-10-AZ	24	C-44-R	30	CH-2	45
BPT-1/1-T	55	C-10-B	24	C-4-B	35	CH-3	45
BPT-1/2-T	55	C-11	24	C-4-M	35	CH-30	44
BPT-1/3-T	55	C-110	198	C-500	39	CH-4	45
BPT-1/4-T	55	C-115	198	C-51	31	CH-40	44
BPT-1/5-T	55	C-11-AZ	24	C-56	31	CH-50	44
BPT-2/5-T	55	C-11-B	24	C-57	37	CH-6	45
BPT-3/4-T	55	C-121	198	C-62	38	CH-7	45
BPT-4015	58	C-122	198	C-63	38	CH-75	44
BPT-6680	58	C-13	26	C-64	38	CP-12	71
BPTR-27-20-N	55	C-130	28	C-65-AZ	24	CP-12- 3;5	71
BPTR-40-20-N	55	C-131	28	C-65-AZB	27	CP-12-3	71
BPTR-40-50-N	55	C-132	26	C-65-B	25	CP-12-4	71
BV-140450	96	C-140	26	C-65-BB	27	CP-12-4;5	71
BV-150200	96	C-141	26	C-65-R	24	CP-12-5	71
BV-150250	96	C-15-N	25	C-65-RB	27	CP-12-6	71
BV-175250	96	C-17	25	C-65-V	24	CP-12-7	71
BV-180300	96	C-1-N	35	C-65-VB	27	CP-12-8	71
BV-200200	96	C-1-P	35	C-65-VF	32	CP-22	71
BV-200250	96	C-1PN	35	C-66	25	CP-22-3	71
BV-200300	96	C-2	29	C-66-B	27	CP-22-3;5	71
BV-200350	96	C-205	35	C-67	27	CP-22-4	71
BV-200400	96	C-210	36	C-67-AZ	27	CP-22-4;5	71
BV-250350	96	C-211	36	C-67-R	27	CP-22-5	71
BV-300400	96	C-212	36	C-68	32	CP-22-6	71
BV-350500	96	C-213	36	C-69	32	CP-22-7	71
BV-350600	96	C-214	36	C-7	29	CP-22-8	71
BV-400500	96	C-215-B	60	C-72	33	CP-2C	71
BV-400600	96	C-215-B	36	C-73	33	CP-2C	71
BVA-1	97	C-215-N	36	C-74	33	CP-32	72
BVA-2	97	C-215-N	60	C-75	33	CP-32-3	72
BVA-3	97	C-24	25	C-76	33	CP-32-3;5	72
BVA-4	97	C-24-B	25	C-76-C	33	CP-32-4	72
BVC-150200	97	C-24-T	25	C-76-T	33	CP-32-4;5	72
BVC-185250	97	C-25	37	C-77	33	CP-32-5	72
BVC-200300	97	C-26	37	C-77-C	34	CP-32-6	72
BVC-250350	97	C-27	37	C-77-T	33	CP-32-7	72
BVC-300400	97	C-28	37	C-79	34		

CP-32-8	72	ET-100-P	127	GI-2/1-65	52	H-E12	146
CP-8	71	ET-100-S	127	GI-2/3-100	52	H-E14	146
CP-8-3	71	ET-108	198	GI-2/3-150	52	H-E16	146
CP-8-3;5	71	ET-15	127	GI-2/3-20	48	H-E18	146
CP-8-4	71	ET-1-A	128	GI-2/3-20	52	H-P23	147
CP-8-4;5	71	ET-1-AZ	128	GI-2/3-200	52	H-P23-C	147
CP-8-5	71	ET-1-B	128	GI-2/3-40	52	H-P33	147
CP-8-6	71	ET-1-G	128	GI-2/3-65	52	H-P33-C	147
CP-8-7	71	ET-1-N	128	GI-2/4-20	48	<b>I</b>	
CP-8-8	71	ET-1-NA	128	GIFP-1/1	54	IT-10	125
<b>D</b>		ET-1-R	128	GIFP-1/2	54	IT-10-1	125
D-1	106	ET-1-V	128	GIFP-2/1	54	IT-103	198
D-11	107	<b>F</b>		GIFP-2/3	54	IT-105	198
D-12	107	F-10	171	GIP-1/1-100	53	IT-105-	198
D-2	106	F-11	171	GIP-1/1-150	53	IT-105-V	198
D-4-B	106	F-12	171	GIP-1/1-20	53	IT-106	198
D-4-C	106	F-13	171	GIP-1/1-200	53	IT-107	198
D-50	107	F-14	171	GIP-1/1-40	53	IT-109	198
D-7	106	F-15	175	GIP-1/1-65	53	IT-11	125
D-7-N	106	F-16	175	GIP-1/2-100	53	IT-110	198
D-8	106	F-17	171	GIP-1/2-150	53	IT-11-1	125
DA-1	81	F-20	175	GIP-1/2-200	53	IT-30	126
DA-18	81	F-21	175	GIP-1/2-65	53	IT-30-MD	126
DB-10	80	F-22	175	GIP-2/1-20	53	IT-4	124
DB-6	80	F-35	169	GIP-2/1-40	53	IT-4-MD	124
DB-8	80	F-36	169	GIP-2/1-65	53	IT-4-X	125
DD-10	80	F-40	169	GIS-325	54	IT-5-MD	122
DD-20	80	<b>G</b>		GIS-530	54	IT-5-MDV	122
DD-8	80	G-0	142	GIT-1/1	53	IT-6	122
DE-1	80	G-00	142	GIT-1/2	53	IT-6-B	122
DE-10	80	G-1	142	GIT-1/3	53	IT-6-E	122
DE-14	80	G-10	142	GIT-1/4	53	IT-6-ECO	122
DE-2	80	G-11	142	GIT-1/6	53	IT-6-MD	123
DE-3	80	G-12	142	GIT-1/9	53	IT-6-MD-ECO	123
DE-4	80	G-13	142	GIT-2/3	53	IT-6-X	123
DE-5	80	G-14	143	GITH-1/1	53	IT-7-MD	123
DE-6	80	G-15	143	GITH-1/2	53	IT-8	123
DE-8	80	G-18	143	GITH-1/3	53	IT-8-MD	124
DH-10	81	G-19	143	GITH-1/4	53	IT-9-MD	124
DH-2;5	81	G-2	142	GITH-1/6	53	ITH-95	126
DH-4	81	G-20	143	GITH-2/3	53	ITR-125	126
DH-6	81	G-3	142	GP-1/1-100	51	<b>K</b>	
DH-8	81	G-4	142	GP-1/1-150	51	K-10	185
DR-0	78	G-5	142	GP-1/1-200	51	K-104	185
DR-2	78	G-6	142	GP-1/1-65	51	K-104-5	185
DR-3	78	G-7	142	GP-1/2-100	51	K-105	185
DR-4	78	G-8	142	GP-1/2-150	51	K-105-5	185
DR-6	78	G-9	142	GP-1/2-200	51	K-106	185
DR-8	78	GI-1/1-100	52	GP-1/2-65	51	K-106-5	185
DRH	78	GI-1/1-150	52	GP-1/3-100	51	K-124	185
DS-1	80	GI-1/1-20	52	GP-1/3-150	51	K-124-5	185
DS-2	80	GI-1/1-20	48	GP-1/3-200	51	K-125	185
DV	80	GI-1/1-200	52	GP-1/3-65	51	K-125-5	185
DX-1	81	GI-1/1-40	52	GP-1/4-100	51	K-126	185
DZ-2	80	GI-1/1-65	52	GP-1/4-150	51	K-126-5	185
DZ-3	80	GI-1/2-100	52	GP-1/4-200	51	K-15	185
DZ-4	80	GI-1/2-150	52	GP-1/4-65	51	K-154	185
DZ-7	80	GI-1/2-20	48	GP-1/6-100	51	K-154-5	185
<b>E</b>		GI-1/2-20	52	GP-1/6-150	51	K-155	185
E-110	151	GI-1/2-200	52	GP-1/6-200	51	K-155-5	185
E-110	201	GI-1/2-40	52	GP-1/6-65	51	K-156	185
E-110-ECO	151	GI-1/2-65	52	GP-1/9-100	51	K-156-6	185
E-110-ECO	201	GI-1/3-100	52	GP-1/9-65	51	K-15-P	185
E-4	150	GI-1/3-150	52	GP-2/1-200	51	K-15-PS	185
E-5	150	GI-1/3-20	52	GPFP-1/1	51	K-15-S	185
E-5-ECO	150	GI-1/3-20	48	GPFP-1/2	51	K-204	185
E-6	151	GI-1/3-200	52	GPFP-2/1	51	K-204-5	185
E-6-ECO	151	GI-1/3-40	52	GPT 1/1	51	K-205	185
EC-1	113	GI-1/3-65	52	GPT 1/2	51	K-205-5	185
EC-10	2	GI-1/4-100	52	GPT 1/3	51	K-206	185
EC-10	113	GI-1/4-150	52	GPT 1/4	51	K-206-5	185
EC-105	115	GI-1/4-20	48	GPT 1/6	51	KBV-100	190
EC-35	115	GI-1/4-20	52	GPT 1/9	51	KBV-150	190
EC-5-45	114	GI-1/4-200	52	GPT 2/1	51	KBV-200	190
EC-55	115	GI-1/4-40	52	<b>H</b>		KL-100	190
EC-710	199	GI-1/4-65	52	H-120NV	146	KL-25	190
EC-711	199	GI-1/6-100	53	H-12SR	146	KL-50	190
EC-712	199	GI-1/6-150	53	H-140NV	146	KL-55	190
EC-713	199	GI-1/6-200	53	H-14SR	146	KM-104	187
EC-714	199	GI-1/9-100	53	H-16SR	146	KM-104-5	187
EC-715	199	GI-1/9-65	53	H-18SR	146	KM-105	187
ECU-100	116	GI-2/1-100	52	H-20SR	146	KM-105-5	187
ECU-15	199	GI-2/1-150	52	H-22R	146	KM-106	187
ECU-25	116	GI-2/1-20	52	H-24R	146	KM-106-5	187
ECU-50	116	GI-2/1-20	48	H-26R	146	KM-124	187
ET-10	127	GI-2/1-200	52	H-28R	146	KM-124-S	187
ET-100	127	GI-2/1-40	52	H-E10	146	KM-125	187

**K-S**

KM-125-5	187
KM-126	187
KM-126-5	187
KM-154	187
KM-154-5	187
KM-155	187
KM-155-5	187
KM-156	187
KM-156-5	187
KM-204	187
KM-204-5	187
KM-205	187
KM-205-5	187
KM-206	187
KM-206-5	187
KP-104	188
KP-105	188
KP-106	188
KP-124	188
KP-125	188
KP-126	188
KP-154	188
KP-155	188
KP-156	188
KP-204	188
KP-205	188
KP-206	188
KP-250	189
KP-300	189
KP-350	189
KP-400	189
KP-500	189
KTA-105	188
KTA-106	188
KTA-107	188
KTA-108	188

**L**

LM-1	111
LM-10	107
LM-10-P	107
LM-11	108
LM-1-1	108
LM-1-2	108
LM-1-3	108
LM-2	112
LM-21	109
LM-2-1	108
LM-21-1	111
LM-21-2	110
LM-21-3	110
LM-21-4	110
LM-22	109
LM-2-2	108
LM-23	109
LM-23-1	111
LM-23-2	110
LM-24	109
LM-25	111
LM-26	109
LM-27	110
LM-2-P	112
LM-4	112
LM-5	112
LMP-4	112
LMP-5	112

**M**

MC-E300	74
MC-E350	74
MC-M350	74
MC-220-AF	75
MC-250-C	75
MC-300-E	75
MC-350-I	75
MC-250-VOL	76
MC-2530	76
MC-3	82
MC-300-VOL	76
MC-5	83
MC-8	83
MC-CD-3	82
MC-CD-5	82
MC-CL-3	82
MC-CL-5	82
MC-CP-3	82
MC-CP-5	82
ME-L14	139
ME-L5	139

ME-L7	139
ME-L8	139
ME-L8V	139
MH-1	136
MH-10	137
MH-101	200
MH-102	200
MH-103	201
MH-104	201
MH-105	200
MH-107	200
MH-108	201
MH-109	201
MH-110	201
MH-111	201
MH-112	201
MH-13	137
MH-15	137
MH-1-R	136
MH-2	136
MH-20	138
MH-21	138
MH-22	138
MH-23	138
MH-25	138
MH-3	136
MH-4	136
MH-5	136
MH-6	137
MH-6-1	200
MH-7	137
MH-7-1	200
MH-8	136
MH-8-1	200
MH-9	136
MH-9-1	200
MP-12MEC-M	64
MP-12MEC-T	64
MP-22 EURO-M	65
MP-22 EURO-T	65
MP22 MEC-M	66
MP-22 MEC-T	66
MP-22RE-T	68
MP-32 MEC-M	67
MP-32 MEC-T	67
MP-32RE-T	69
MP-8-M	70
MPE-18	84
MPP-10	85
MPQ-02	78
MPQ-MOZ-15	77
MPQ-MOZZARELLA	77
MPQV-5-M	79
MPQV-5-T	79
MR-1	88
MR-10	90
MR-10-1	90
MR-103-I	160
MR-104-I	160
MR-105-I	160
MR-107-N	159
MR-108-N	159
MR-109-N	159
MR-11	90
MR-110	159
MR-115-I	160
MR-119-I	160
MR-12	90
MR-13	90
MR-14	90
MR-15	92
MR-1-ECO	88
MR-2	89
MR-20	89
MR-201	200
MR-201-ECO	200
MR-202	200
MR-202-ECO	200
MR-203	200
MR-204	200
MR-205	200
MR-206	200
MR-206-ECO	200
MR-207	200
MR-208	200
MR-209	200
MR-210	200

MR-215	200
MR-3	89
MR-30	89
MR-4	88
MR-40	89
MR-45	89
MR-4-500	88
MR-4-500-ECO	88
MR-46	89
MR-4-600	88
MR-47	89
MR-49	89
MR-4-ECO	88
MR-5	90
MR-50	89
MR-6	90
MR-60	89
MR-80	91
MR-9	91
MR-90	91
MRI-5	90
MRI-6	90
MRIT-5	90
MRIT-6	90
MSE-10	78
MT-152	98
MT-192	98
MT-270	99
MTB-15	99
MTB-20	99
MTB-27	99
MTM-1/2	99
MTM-1/4	99
MV-10	93
MV-16	93
MV-21	93
MVS-100	94
MVS-330	94
MVS-430	93

**N**

N-20	152
N-21	152
N-22	152
N-3	152
N-30	152
N-31	152
N-32	152
N-9	152

**O**

OR-2	128
OR-2M	128
OZ-10G	113

**P**

PB-1	103
PB-10	105
PB-11	105
PB-12	104
PB-1-M	103
PB-2	103
PB-21	103
PB-21N	103
PB-22	104
PB-22N	104
PB-23	104
PB-23N	104
PB-24	104
PB-24N	104
PB-3	103
PB-30	105
PB-40	105
PB-50	105
PB-7	104
PB-70	105
PB-8	104
PB-9	104
PH-3	138
PH-4	138
PH-5	138
PH-6	138
PH-7	138
PH-8	138
PR-20	145
PR-25	145
PS-60	138
PS-70	138
PS-80	138

**R**

R-100	158
R-10-BE	154
R-10-BEP	154
R-10-G	154
R-10-GP	154
R-20	154
R-2020-AZ	156
R-2020-R	156
R-2020-V	156
R-2021	156
R-2032-AZ	156
R-2032-R	156
R-2032-V	156
R-2054-AZ	156
R-2054-R	156
R-2054-V	156
R-21	154
R-22	154
R-30	155
R-31	155
R-40	44
R-50	157
R-75	158
R-80	157
RB-4-A	150
RB-4-AZ	150
RB-4-B	150
RB-4-R	150
RB-4-T	150
RB-4-V	150
R-CI	158
R-CI110	157
RE-5-B	151
RE-5-N	151
RE-6-B	151
RE-6-N	151
RE-7	151
RE-8	151
R-PM	158
R-PM110	157
RT-5-A	128
RT-5-AZ	128
RT-5-B	128
RT-5-R	128
RT-5-V	128
RT-6-A	128
RT-6-AZ	128
RT-6-B	128
RT-6-R	128
RT-6-V	128

**S**

SB-1000	91
SB-1001	199
SB-200	91
SB-201	199
SB-202	199
SB-300	91
SB-301	199
SB-302	199
SB-400	91
SB-400-ECO	91
SB-401	199
SB-402	199
SB-451	199
SB-500	91
SB-500-ECO	91
SB-501	199
SB-502	199
SB-600	91
SB-601	199
SB-602	199
SBM-500	92
SBM-505	92
SBPA-450	92
SBPA-451	199
SBPA-600	92
SBPA-601	199
SCA-1600	73
SCA-1740	73
SCA-1750	73
SCA-1985	73
SCA-2120	73
SCA-2340	73
SCA-2520	73
SCA-2930	73
SCO-1600	73

SCO-1740	73	V-FA454520PL	11	V-H33331.5	8	V-H60404	9
SCO-1750	73	V-FA505020PL	11	V-H33332	8	V-H60405	9
SCO-1985	73	V-FA604020PL	11	V-H33333	8	V-H60409	10
SCO-2120	73	V-FA644520PL	11	V-H33334	9	V-H65455	9
SCO-2340	73	V-FA705020PL	11	V-H33335	9	V-H70505	9
SCO-2520	73	V-FI1005020PL	11	V-H3514	10	V-H75251.5	8
SCO-2930	73	V-FI21005020PL	11	V-H355	10	V-H75252	8
SHU-1600	73	V-FI2404020PL	11	V-H359	10	V-H75253	8
SHU-1740	73	V-FI2454520PL	11	V-H4014	10	V-H75254	9
SHU-1750	73	V-FI2505020PL	11	V-H40201.5	8	V-H75255	9
SHU-1985	73	V-FI2604020PL	11	V-H40202	8	V-H75331.5	8
SHU-2120	73	V-FI2644520PL	11	V-H40203	8	V-H75332	8
SHU-2340	73	V-FI2705020PL	11	V-H40204	9	V-H75333	8
SHU-2520	73	V-FI404020PL	11	V-H40205	9	V-H75334	9
SHU-2930	73	V-FI454520PL	11	V-H40251.5	8	V-H75335	9
SJ-10	141	V-FI505020PL	11	V-H40252	8	V-H80405	9
SJ-12	142	V-FI604020PL	11	V-H40253	8	V-H90455	9
SJ-15	141	V-FI644520PL	11	V-H40254	9	V-HAGU14	10
SJ-16	141	V-FI705020PL	11	V-H40255	9	V-HAGU5	10
SJ-18	141	V-FS454520PL	12	V-H40301.5	8	V-HAGU9	10
SJ-20	140	V-FS604020PL	12	V-H40302	8	V-HC10020	16
SJ-4	140	V-FS705020PL	12	V-H40303	8	V-HC3320	16
SJ-500	141	V-G1005025E	6	V-H40304	9	V-HC5020	16
SJ-5-M	140	V-G443210E	6	V-H40305	9	V-HG40302V	19
SJ-600	141	V-G443215E	6	V-H4031.5	8	V-HRP-40302S	17
SJ-600-R	141	V-G443220E	6	V-H403314	10	V-I1005025E	4
SJ-6-B	140	V-G443225E	6	V-H40332	8	V-I21005025E	4
SJ-8	140	V-G604015E	6	V-H40333	8	V-I2404025E	4
SJ-9	140	V-G604025E	6	V-H40334	9	V-I2444425E	4
SM-5	102	V-G644425E	6	V-H40335	9	V-I2505025E	4
SM-6	102	V-G705025E	6	V-H40339	10	V-I2604025E	4
SM-700	102	V-G804025E	6	V-H40401.5	8	V-I2644425E	4
SPI-6	18	V-G806015E	6	V-H40402	8	V-I2705025E	4
<b>T</b>		V-G884425E	6	V-H40403	8	V-I2804025E	4
T-002	147	V-GOMA	3	V-H40404	9	V-I2884425E	4
T-003	147	V-GUIA-40	3	V-H40405	9	V-I404025E	4
T-005	147	V-H100251.5	8	V-H40409	10	V-I444425E	4
T-007	147	V-H100252	8	V-H405	10	V-I505025E	4
T-008	148	V-H100253	8	V-H409	10	V-I604025E	4
T-009	147	V-H100254	9	V-H45455	9	V-I644425E	4
T-012	148	V-H100255	9	V-H45459	10	V-I705025E	4
T-050	148	V-H100331.5	8	V-H50251.5	8	V-I804025E	4
T-360	144	V-H100332	8	V-H50252	8	V-I884425E	4
TA-002	148	V-H100333	8	V-H50253	8	V-K40405	13
TC-180	172	V-H100334	9	V-H50254	9	V-K40409	13
TC-200	172	V-H100335	9	V-H50255	9	V-K45455	13
TC-220	172	V-H100505	9	V-H50301.5	8	V-K45459	13
TC-240	172	V-H150251.5	8	V-H50302	8	V-K50505	13
TC-280	172	V-H150252	8	V-H50303	8	V-K50509	13
TF-200	172	V-H150253	8	V-H50304	9	V-K540405	13
TF-225	172	V-H150254	9	V-H50305	9	V-K540409	13
TM-430	173	V-H150255	9	V-H50331.5	8	V-K545455	13
TM-500	173	V-H150331.5	8	V-H503314	10	V-K545459	13
TP-210	172	V-H150332	8	V-H50332	8	V-K550505	13
TP-230	172	V-H150333	8	V-H50333	8	V-K550509	13
TP-250	172	V-H150334	9	V-H50334	9	V-K560405	13
TT-265	172	V-H150335	9	V-H50335	9	V-K560409	13
<b>V</b>		V-H2001001.5	8	V-H50339	10	V-K570505	13
V-A1005025E	3	V-H2001002	8	V-H50401.5	8	V-K570509	13
V-A404015E	3	V-H2001003	8	V-H50402	8	V-K60405	13
V-A404025E	3	V-H2001004	9	V-H50403	8	V-K60409	13
V-A443215E	3	V-H2001005	9	V-H50404	9	V-K70505	13
V-A444425E	3	V-H200251.5	8	V-H50405	9	V-K70509	13
V-A505025E	3	V-H200252	8	V-H50501.5	8	V-L240405	12
V-A604015E	3	V-H200253	8	V-H50502	8	V-L240409	12
V-A604025E	3	V-H200254	9	V-H50503	8	V-L245455	12
V-A644425E	3	V-H200255	9	V-h50504	9	V-L245459	12
V-A705025E	3	V-H200331.5	8	V-H50505	9	V-L250505	12
V-A804025E	3	V-H200332	8	V-H50509	10	V-L250509	12
V-A806015E	3	V-H200333	8	V-H60251.5	8	V-L260405	12
V-A884425E	3	V-H200334	9	V-H60252	8	V-L260409	12
V-BPGD	7	V-H200335	9	V-H60253	8	V-L270505	12
V-BPGDI	7	V-H25191.5	8	V-H60254	9	V-L270509	12
V-F404020PL	10	V-H25192	8	V-H60255	9	V-MC60505	19
V-F404025PL	10	V-H25193	8	V-H60301.5	8	V-MC60505-R	19
V-F454520PL	10	V-H25194	9	V-H60302	8	V-MI10060C	14
V-F454525PL	10	V-H25195	9	V-H60303	8	V-MI10060S	14
V-F505020PL	10	V-H30201.5	8	V-H60304	9	V-MI10070C	14
V-F505025PL	10	V-H30202	8	V-H60305	9	V-MI10070S	14
V-F604020PL	10	V-H30203	8	V-H60331.5	8	V-MI15060C	14
V-F604025PL	10	V-H30204	9	V-H60332	8	V-MI15060S	14
V-F644520PL	10	V-H30205	9	V-H60333	8	V-MI15070C	14
V-F644525PL	10	V-H33191.5	8	V-H60334	9	V-MI15070S	14
V-F705020PL	10	V-H33192	8	V-H60335	9	V-MI20060C	14
V-F705025PL	10	V-H33193	8	V-H60401.5	8	V-MI20060S	14
V-FA1005020PL	11	V-H33194	9	V-H60402	8	V-MI20070C	14
V-FA404020PL	11	V-H33195	9	V-H60403	8	V-MI20070S	14

## V-Z

V-MI5050	14	V-PORACE-44	2	X-2902	43
V-MI7050	14	V-PORACE-50	2	X-2903	43
V-MIS	14	V-PORMAD	2	X-2904	43
V-MM10060XC	15	V-PORPOLB	2	X-2905	43
V-MM10060XS	15	V-PORPOLR	2	X-2906	43
V-MM10070XC	15	V-PR	3	X-2907	43
V-MM10070XS	15	V-S443225E	5	X-2909	43
V-MM15060XC	15	V-S444425E	5	X-2910	43
V-MM15060XS	15	V-S604025E	5	X-6886	43
V-MM15070XC	15	V-S705025E	5	X-9005	43
V-MM15070XS	15	V-SP2B	19	<b>Y</b>	
V-MM20060XC	15	V-SP2M	19	Y-30201	10
V-MM20060XS	15	V-SP2R	19	Y-40302	10
V-MM20070XC	15	V-T50355	6	Y-50302	10
V-MM20070XS	15	V-T50405	6	Y-60402	10
V-MP10060XC	15	V-TP30202	19	<b>Z</b>	
V-MP10060XS	15	V-TP35252	19	Z-10	202
V-MP10070XC	15	V-VALDILLA	3	Z-11	202
V-MP10070XS	15	<b>W</b>		Z-11-U	202
V-MP15060XC	15	W-120	117	Z-15	202
V-MP15060XS	15	W-240	117	Z-151	129
V-MP15070XC	15	W-28	118	Z-20	202
V-MP15070XS	15	W-60	117	Z-20-F	202
V-MP20060XC	15	W-80	117	Z-21	202
V-MP20060XS	15	W-81	118	Z-40	202
V-MP20070XC	15	WI-110	120	Z-420-MD	129
V-MP20070XS	15	WI-35	118	Z-430-MD	129
V-MX10050XC	16	WI-60	120	Z-440-MD	129
V-MX10050XS	16	WI-70	119	Z-600	129
V-MX10060XC	16	WI-75	119	Z-700	129
V-MX10060XS	16	WI-90	119	Z-780	129
V-MX10070XC	16	<b>X</b>		Z-911	130
V-MX10070XS	16	X-0024	41	Z-911-A	130
V-MX15050XC	16	X-0100	42	Z-911-N	130
V-MX15050XS	16	X-0101	42	Z-918	130
V-MX15060XC	16	X-0102	42	Z-918-A	130
V-MX15060XS	16	X-0200	42	Z-918-N	130
V-MX15070XC	16	X-0201	42	Z-930	132
V-MX15070XS	16	X-0202	42	Z-930-A	132
V-MX20050XC	16	X-0203	42	Z-950	131
V-MX20050XS	16	X-0204	42	Z-950-A	131
V-MX20060XC	16	X-0210	42	Z-960	131
V-MX20060XS	16	X-0724	41	Z-960-A	131
V-MX20070XC	16	X-2500	40		
V-MX20070XS	16	X-2503	40		
V-O3510E	6	X-2504	40		
V-O3515E	6	X-2505	40		
V-O3520E	6	X-2509	40		
V-O404015E	5	X-2514	40		
V-O404025E	5	X-2515	41		
V-O444410E	5	X-2530	41		
V-O444420E	5	X-2800	40		
V-O444425E	5	X-2801	40		
V-O505025E	5	X-2804	40		
V-PF	3	X-2900	43		
V-PORACE-40	2	X-2901	43		

---

## CONDICIONES GENERALES DE VENTA

### PORTES

- La mercancía viajará **A PORTES PAGADOS** hasta su destino en pedidos superiores a 450 euros netos siempre que sea dentro de la península.
- Para Baleares la franquicia de portes será a partir de 600 euros netos.
- Para las Islas Canarias la franquicia de portes será a partir de 900 euros netos.
- Para Ceuta y Melilla la franquicia de portes será de 450 euros netos hasta puerto península.
- Para países de la CEE consultar.
- Para pedidos inferiores a las cantidades anteriormente descritas, Sacopisa ofrece cargar los portes en factura, viajando la mercancía por la empresa de transporte escogida por Sacopisa.

### RECLAMACIONES

- La mercancía viajará por cuenta y riesgo del comprador debiendo notificar cualquier reclamación antes de 24

horas y haciéndolo constar ante la empresa de transportes.

- Rogamos hacer constar siempre en la entrega del transportista **"SALVO EXAMEN"** si no se puede revisar la mercancía en ese momento.

### DEVOLUCIONES

- **NO SE ACEPTARÁN DEVOLUCIONES** sin antes comunicarlo a Sacopisa por teléfono o fax recibiendo el **CÓDIGO DE DEVOLUCIÓN**.
- El **CÓDIGO DE DEVOLUCIÓN** tiene que estar en un sitio visible del bulto y en su albarán.

### PEDIDOS MÍNIMOS

- Pedidos mínimos 100 euros netos. Inferiores se cargaran 10 euros gastos de administración.

### CONFLICTOS

- En caso de litigio se resolverán en el juzgado correspondiente a la plaza del vendedor con renuncia de cualquier otro fuero.

---

## GENERAL SALES CONDITIONS

- FREIGHT CONDITIONS WILL VARY IN ACCORDANCE WITH THE COUNTRY
- RETURNS ARE NOT ACCEPTED WITHOUT COMMUNICATE IT PREVIOUSLY BY PHONE, FAX OR E-MAIL
- IN CASE OF LAWSUIT, IT WILL BE SETTLED IN THE VENDOR CLOSER COURT, ANY OTHER JURISDICTION WILL BE REFUSED.

---

## CONDITIONS GÉNÉRALES DE VENTE

- LES CONDITIONS DE TRANSPORT VARIENT SELON LE PAYS DE DESTINATION
  - AUCUN RETOUR SERA ACCEPTÉ SANS PRÉVENIR SACOPISA PAR TÉLÉPHONE, FAX OU E-MAIL
  - EN CAS DE LITIGE, SERA RÉSOLU DANS LA COUR PLUS PROCHE DU VENDEUR, RENONÇANT À TOUTE AUTRE JURISDICTION
-



**SACOPISA S.L.**

Pol. Can Casablanques, C/ Vallès, 5

Tel. +34 93 721 48 41 · +34 93 721 30 38 · Fax +34 93 721 40 24

08192 Sant Quirze del Vallès · Barcelona - España

Apartado de correos 349 – 08200 Sabadell

**[www.sacopisa.com](http://www.sacopisa.com)**

[sacopisa@sacopisa.com](mailto:sacopisa@sacopisa.com) | [pedidos@sacopisa.com](mailto:pedidos@sacopisa.com) | [export@sacopisa.com](mailto:export@sacopisa.com)